



YAMAHA

GENUINE

PARTS CATALOGUE

GOLF CAR

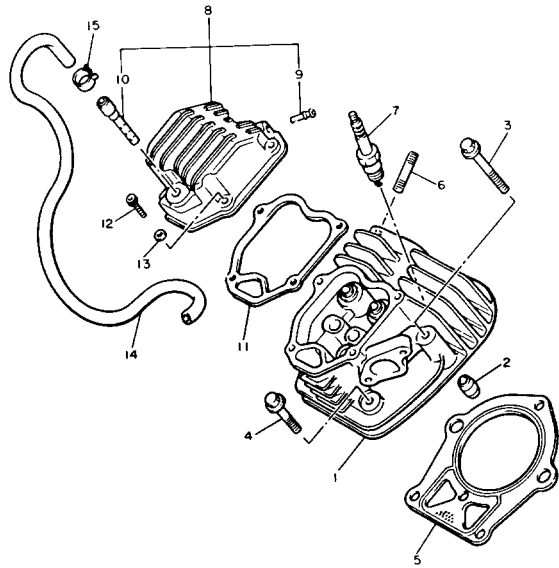

CYLINDER

Ref. No.	Part Number	Description	Qty	Remarks
1	J38-11102-00-00	CYLINDER HEAD ASSEMBLY .	1	
2	99510-12016-00	PIN, DOWEL	2	
3	95811-08070-00	BOLT, FLANGE	3	
4	95811-08045-00	BOLT, FLANGE	3	
5	J38-11181-00-00	GASKET, CYLINDER HEAD 1 .	1	
6	95612-08618-00	BOLT, STUD	2	
7	NGK-B5ES0-00-00	PLUG, SPARK (NGK B5ES) ...	1	
8	J38-11191-00-00	COVER, CYLINDER HEAD 1 ..	1	
9	J38-11116-00-00	. JOINT, BREATHER	2	
10	J38-24461-00-00	. PIPE, JOINT	1	
11	J38-11193-00-00	GASKET, head cover 1	1	
12	91316-06025-00	BOLT	4	
13	92990-06600-00	WASHER, PLATE	4	
14	90445-130F8-00	HOSE	1	
15	90467-11044-00	CLIP	2	

CRANKSHAFT - PISTON

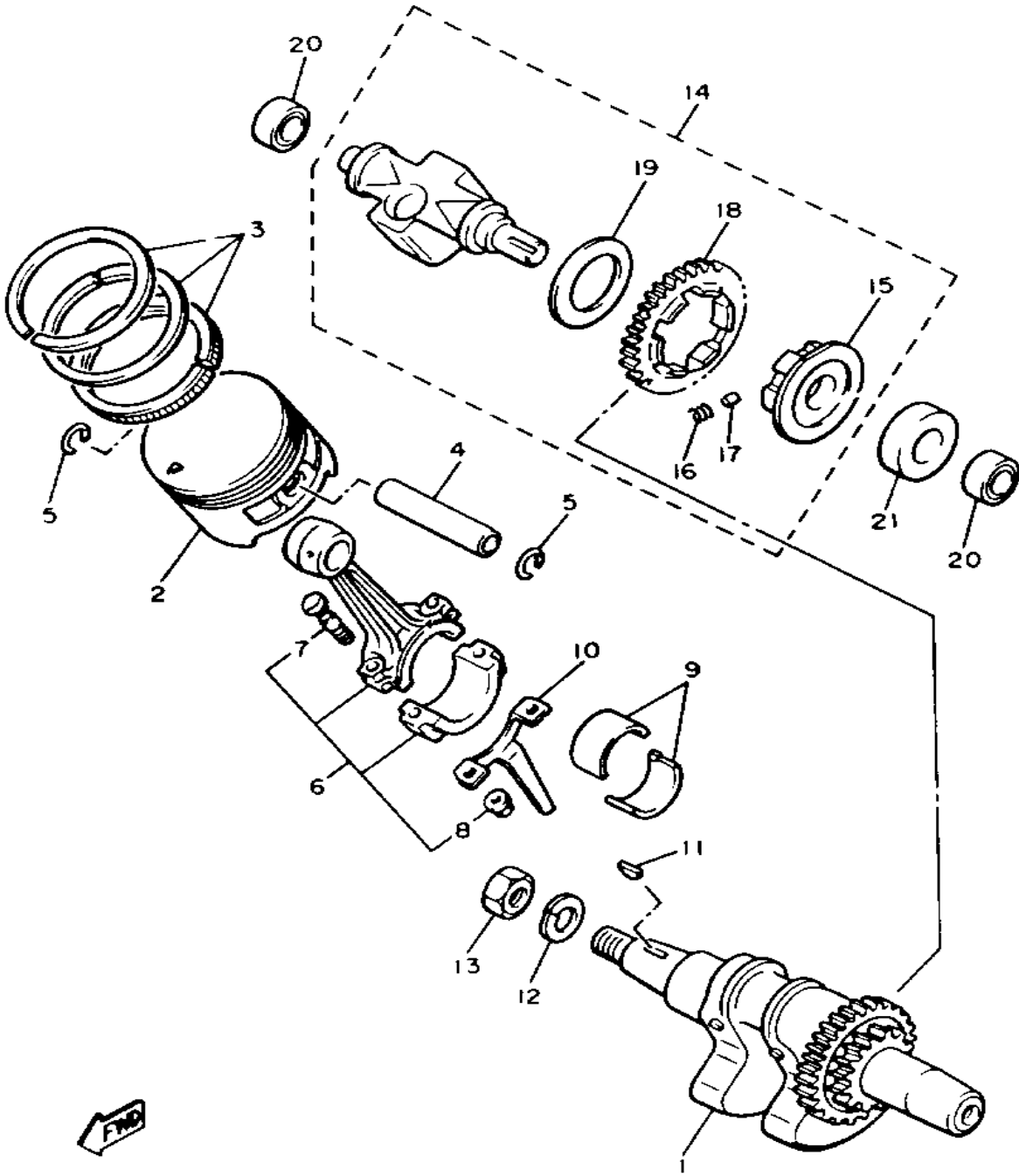

Ref. No.	Part Number	Description	Qty	Remarks
1	J38-11400-00-00	CRANKSHAFT ASSEMBLY	1	
2	7A9-11633-00-00	. PIN, PISTON	1	
	93450-19047-00	. CIRCLIP	1	
	93450-19047-00	. CIRCLIP	2	
	99999-01891-00	PISTON (STD) (J38-11631-00-A0)	1	UR STD
	99999-01892-00	PISTON (0.25MM O/S) (J38-11635-00)	1	Alt. Part
	99999-01893-00	PISTON (0.50MM O/S) (J38-11636-00)	1	Alt. Part
	J38-11631-01-A0	. PISTON (STD)	1	
	J38-11635-01-00	. PISTON (0.25MM O/S)	1	
	J38-11636-01-00	. PISTON (0.50MM O/S)	1	
	JA9-11633-00-00	. PIN, piston	1	
3	J38-11610-00-00	PISTON RING SET (STD)	1	UR
	J38-11610-10-00	PISTON RING SET (0.25MM O/S)	1	Alt. Part
4	2F1-11633-00-00	PIN, piston	1	
5	93450-19052-00	CIRCLIP, INNER	2	
6	J38-11650-00-00	CONNECTING ROD ASSEMBLY	1	
7	J38-11654-00-00	. BOLT, CONNECTING ROD	2	
8	90179-08327-00	. NUT	2	
9	J38-11656-00-00	BEARING, CON-ROD	2	UR Brown
	J38-11656-10-00	BEARING, CON-ROD	2	UR Black
	J38-11656-20-00	BEARING, CON-ROD	2	UR Blue
10	J38-11657-00-00	SPLASHER, OIL	1	
11	90280-16053-00	KEY, WOODRUFF (90280-05048-00)	1	
12	92901-16100-00	WASHER, SPRING	1	
13	90170-16182-00	NUT, HEXAGON	1	

CONTINUED ON NEXT FRAME ►

CRANKSHAFT - PISTON

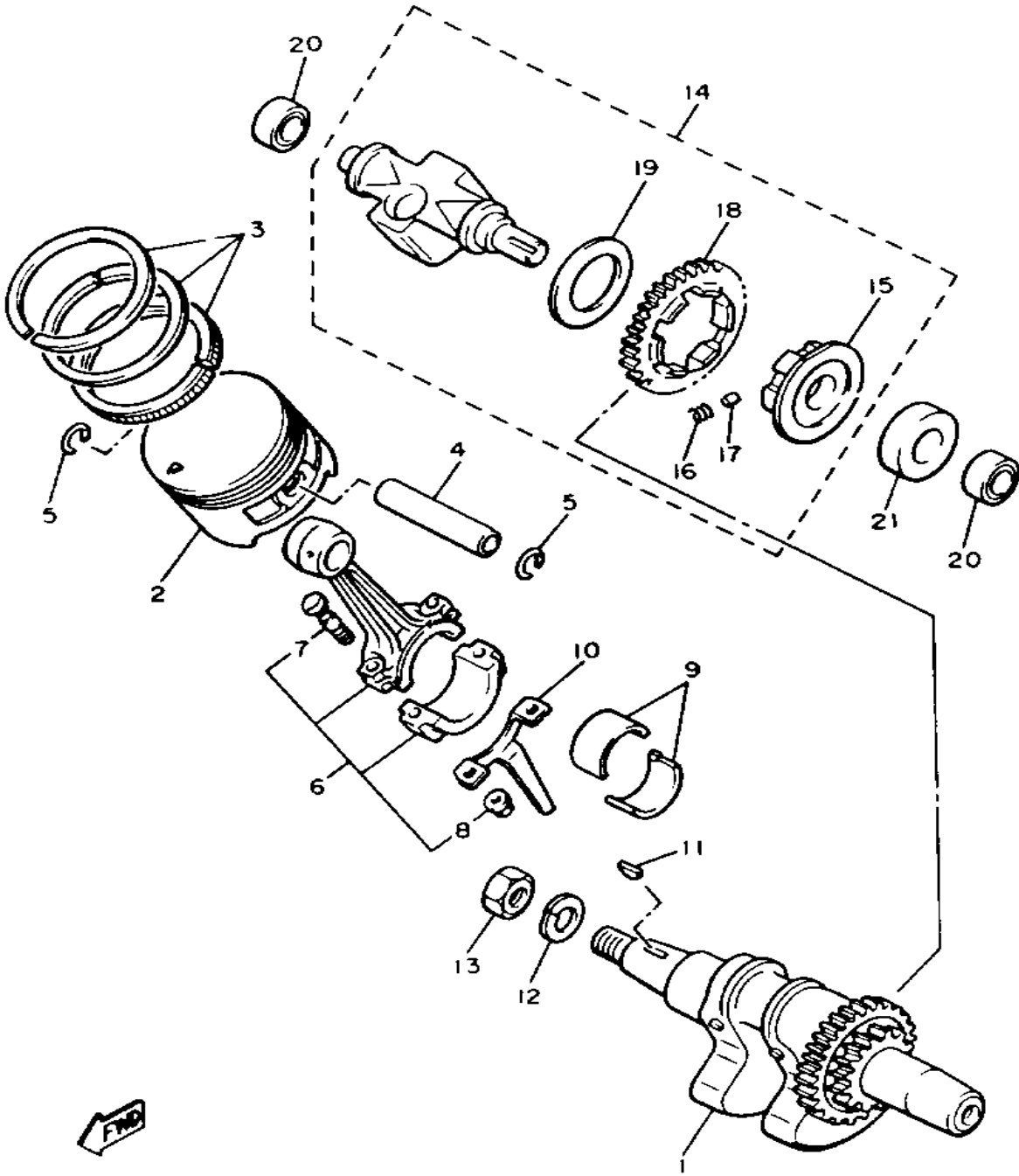

Ref. No.	Part Number	Description	Qty	Remarks
14	J38-11500-00-00	BALANCER ASSEMBLY	1	
15	25G-11496-00-00	. BOSS, buffer	1	
16	90501-21133-00	. SPRING, COMPRESSION	6	
17	93605-10090-00	. PIN, DOWEL	3	
18	J38-11531-00-00	. GEAR, BALANCE WT	1	
19	90201-201G9-00	. WASHER, PLATE	1	
20	93318-31507-00	BEARING, cylindrical	2	
21	90387-152M7-00	COLLAR	1	

VALVE

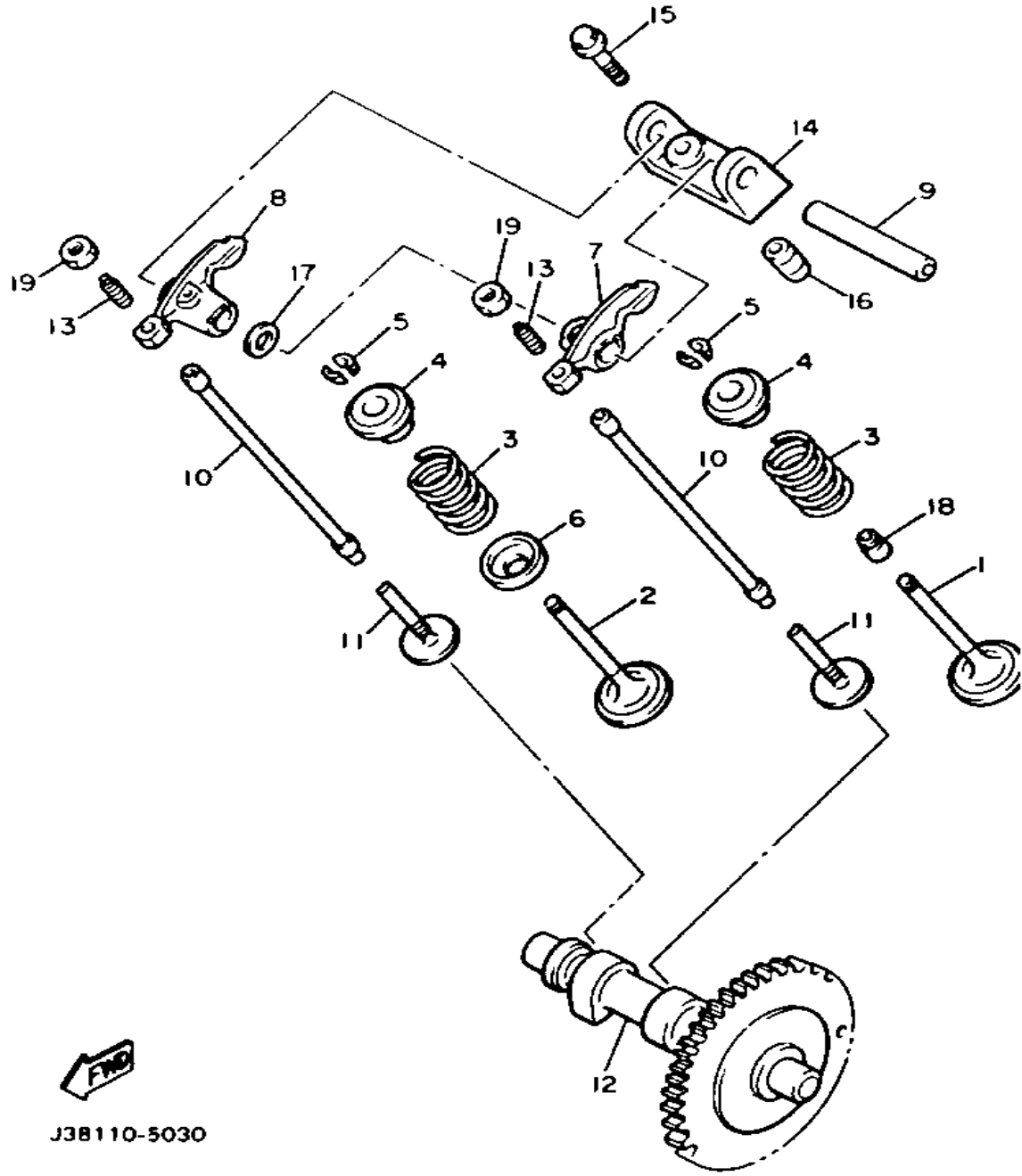

J38110-5030

Ref. No.	Part Number	Description	Qty	Remarks
1	99999-01846-00	VALVE, intake (J38-12111-00)	1	
	J38-12111-01-00	. VALVE, INTAKE	1	
	J38-12117-01-00	. RETAINER, VALVE SPR	1	
	J38-12118-00-00	. COTTER, VALVE	1	
2	99999-01847-00	VALVE, exhaust (J38-12121-00)	1	
	J38-12117-01-00	. RETAINER, VALVE SPR	1	
	J38-12121-01-00	. VALVE, EXHAUST	1	
3	90501-264A9-00	SPRING, COMPRESSION	2	
4	J38-12117-00-00	RETAINER, valve spring	2	
5	4G0-12118-00-00	COTTER, VALVE	4	
6	J38-12219-00-00	SEAT, spring	1	
7	J38-12151-00-00	ARM, valve rocker	1	
8	J38-12161-00-00	ARM, valve rocker 2	1	
9	J38-12156-00-00	SHAFT, ROCKER 2	1	
10	J38-12154-00-00	ROD, VALVE PUSH	2	
11	J38-12153-00-00	LIFTER, VALVE	2	
12	J38-12171-00-00	CAMSHAFT 1	1	
13	J38-12159-00-00	SCREW, VALVE ADJUSTING	2	
14	J38-12152-00-00	SUPPORT, ROCKER ARM	1	
15	95811-06030-00	BOLT, FLANGE (95802-06030)	2	
16	91810-09014-00	PIN, DOWEL	2	
17	90201-127J1-00	WASHER, plate	1	
18	5H0-12119-00-00	SEAL, VALVE STEM	1	
19	90170-06128-00	NUT	2	

AIR SHROUD - FAN

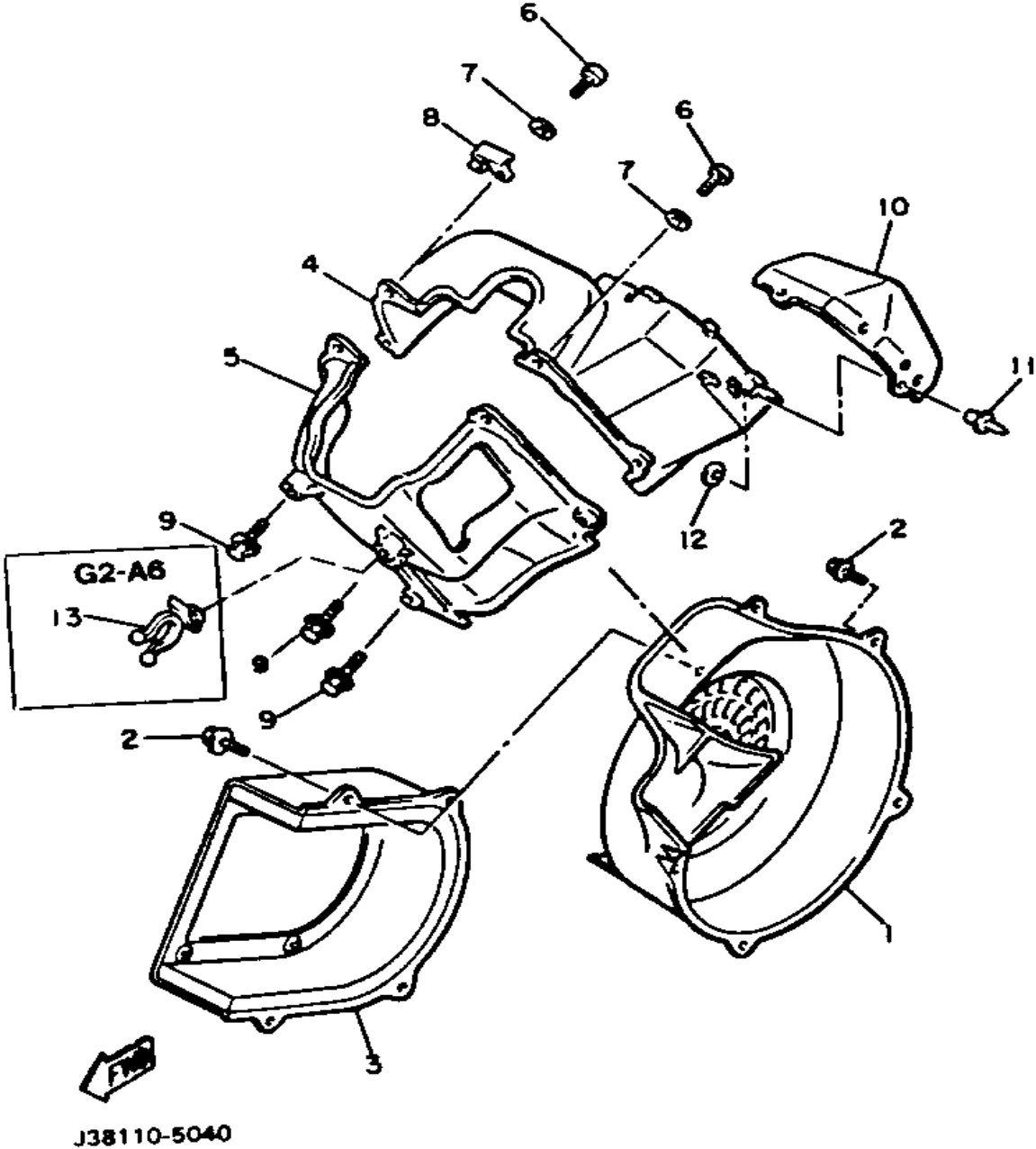

Ref. No.	Part Number	Description	Qty	Remarks
1	97780-60116-00	. SCREW, TAPPING	4	
	99999-01691-00	CASE, fan (J38-12621-00)	1	
	J38-12621-01-00	. CASE, FAN	1	
2	95811-06020-00	BOLT, FLANGE	9	
3	J38-12640-00-00	FAN CASE COVER COMP.	1	
4	J38-12651-01-00	AIR SHROUD, CYLINDER 1	1	
5	J38-12652-00-00	AIR SHROUD, CYLINDER 2	1	
6	98503-06014-00	SCREW, PAN HEAD (92501-06015)	4	
7	92990-06600-00	WASHER, PLATE	4	
8	90465-10129-00	CLAMP	1	
9	90109-06513-00	BOLT	4	
10	J38-12631-00-00	DEFLECTOR 1	1	
11	90267-48086-00	RIVET, BLIND	2	
12	90201-04325-00	WASHER, PLATE	2	
13	(90464-13066-00)	CLAMP	1	

AIR FILTER

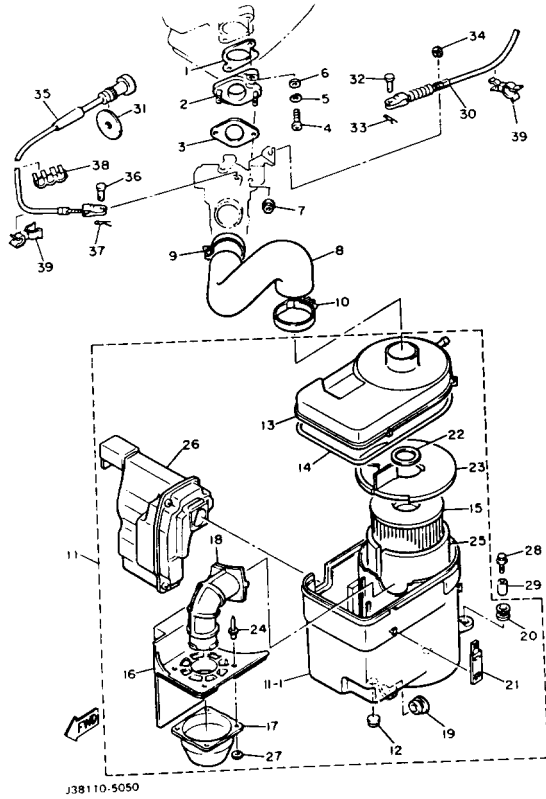

Ref. No.	Part Number	Description	Qty	Remarks
1	J38-13556-00-00	GASKET, MANIFOLD	1	
2	J38-13596-00-00	JOINT, CARBURETOR 2	1	
3	J38-13557-00-00	GASKET	1	
4	98580-06030-00	SCREW PAN HEAD	2	
5	92995-06100-00	WASHER, SPRING (92990-06100-00)	2	
6	92990-06600-00	WASHER, PLATE	2	
7	95601-06200-00	NUT, U FLANGE	2	
8	J38-14453-01-00	JOINT, AIR CLEANER 1	1	
9	90460-43279-00	CLAMP, HOSE	1	
10	90460-53239-00	CLAMP, HOSE	1	
11	J38-14410-01-00	AIR CLEANER ASSEMBLY 1	1	
12	90480-14100-00	. GROMMET	2	
13	J38-14412-02-00	. CAP, CLEANER CASE 1	1	
14	55K-14476-00-00	. SEAL	1	
15	J38-14450-00-00	. ELEMENT ASSEMBLY, AIR CLEANER	1	
16	J38-14484-00-00	. PLATE, CLEANER CASE FITTING	1	
17	J38-14479-00-00	. FUNNEL	1	
18	J38-14419-00-00	. PIPE	1	
19	90480-18277-00	. GROMMET	1	
20	90480-13238-00	. GROMMET	2	
21	J10-14436-00-00	. HOOK	4	
22	J38-14416-00-00	. GASKET, AIR CLEANER	1	
23	J38-1441F-00-00	. PARTN, AIR CLNR CSAIR CLEANER CASE	1	
24	90267-40073-00	. RIVET, BLIND	4	
25	J10-14417-00-00	. COVER 1	1	
26	J38-1446A-00-00	. SURGE TANK ASSEMBLY	1	

CONTINUED ON NEXT FRAME ►

AIR FILTER

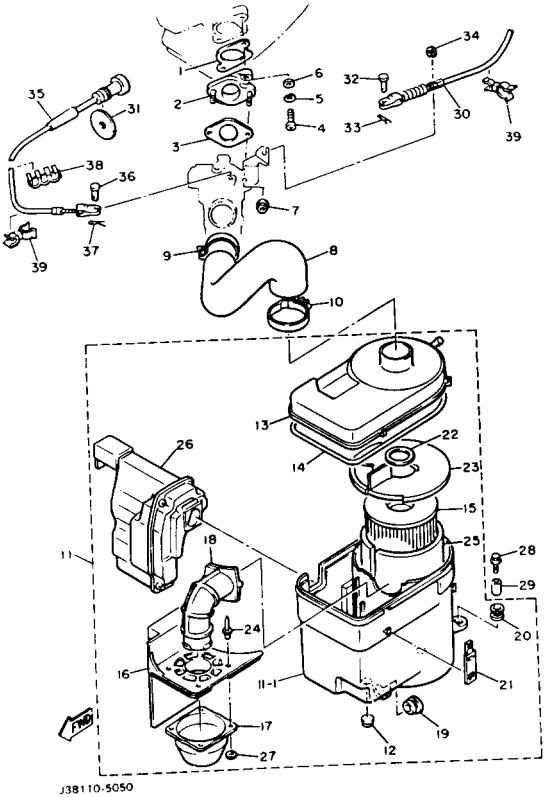

Ref. No.	Part Number	Description	Qty	Remarks
27	92990-04200-00	. WASHER, PLAIN	4	
28	90119-06097-00	BOLT, WITH WASHER	2	
29	90387-07390-00	COLLAR	2	
30	J38-26312-00-00	CABLE, THROTTLE 2	1	
31	90201-114E6-00	WASHER, PLATE	1	
32	91701-05010-00	PIN, CYLINDER. HEAD	2	
33	90468-10050-00	CLIP	2	
34	99080-07600-00	CIRCLIP	1	
35	JF2-F6331-00-00	CABLE, STARTER 1	1	
36	91701-05010-00	PIN, CYLINDER. HEAD	1	
37	90468-10050-00	CLIP	1	
38	90468-07179-00	CLIP	1	
39	90468-80181-00	CLIP	2	
11-1	J38-14411-00-00	. CASE, AIR CLEANER 1	1	

CARBURETOR

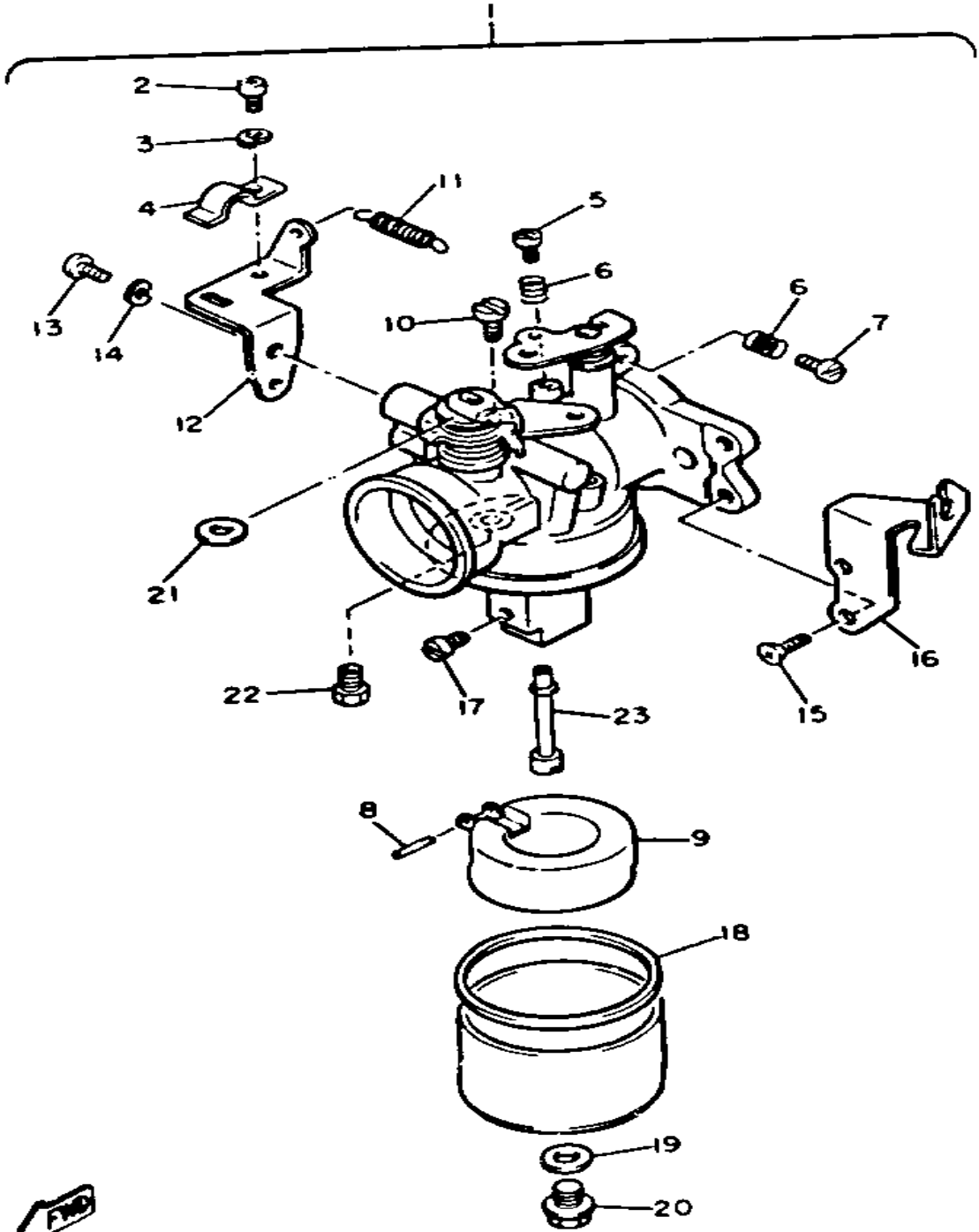

J38110-5060

Ref. No.	Part Number	Description	Qty	Remarks
1	J38-14101-00-00	CARBURETOR ASSEMBLY 1	1	
2	98501-05010-00	. SCREW, PAN HEAD	1	
3	92990-05100-00	. WASHER, SPRING	1	
4	J10-14243-00-00	. PLATE	1	
5	75G-14211-00-00	. SCREW, PILOT ADJUSTING	1	
6	620-14212-00-00	. SPRING, PILOT ADJUSTING	2	
7	J10-14122-00-00	. SCREW, THROTTLE	1	
8	J38-14186-00-00	. PIN, FLOAT	1	
9	J38-14185-00-00	. FLOAT	1	
10	620-14142-67-00	. JET, PILOT (#67.5)	1	Alt. Part
	620-14142-72-00	. JET, PILOT (#72.5)	1	Std
11	J38-14133-00-00	. SPRING, THROTTLE STOP	1	
12	J38-14581-00-00	. BRACKET	1	
13	98580-06010-00	. SCREW, PAN HEAD	1	
14	92995-06100-00	. WASHER, SPRING (92990-06100-00)	1	
15	98701-05008-00	. SCREW, FLAT HEAD	2	
16	J38-14291-00-00	. BRACKET 1	1	
17	3G2-1423E-41-00	. JET, MAIN (#103.8)	1	Alt. Part
	3G2-1423E-42-00	. JET, MAIN (#106.3)	1	Std
18	796-14184-00-00	. GASKET, FLOAT CHMBR	1	
19	127-14198-00-00	. GASKET	1	
20	7R1-14162-00-00	. BOLT, HOLDING	1	
21	J10-14597-00-00	. WASHER	1	
22	J38-14150-00-00	. NEEDLE ASSEMBLY	1	
23	J10-14131-00-00	SPRING, THROTTLE	1	OPTIONAL PART
	J10-14535-00-00	BUSHING, THROTTLE SHAFT	1	OPTIONAL PART
	J10-14582-00-00	ARM, CHOKE	1	OPTIONAL PART
	J38-14141-00-00	. NOZZLE, MAIN	1	

CONTINUED ON NEXT FRAME ►

CARBURETOR

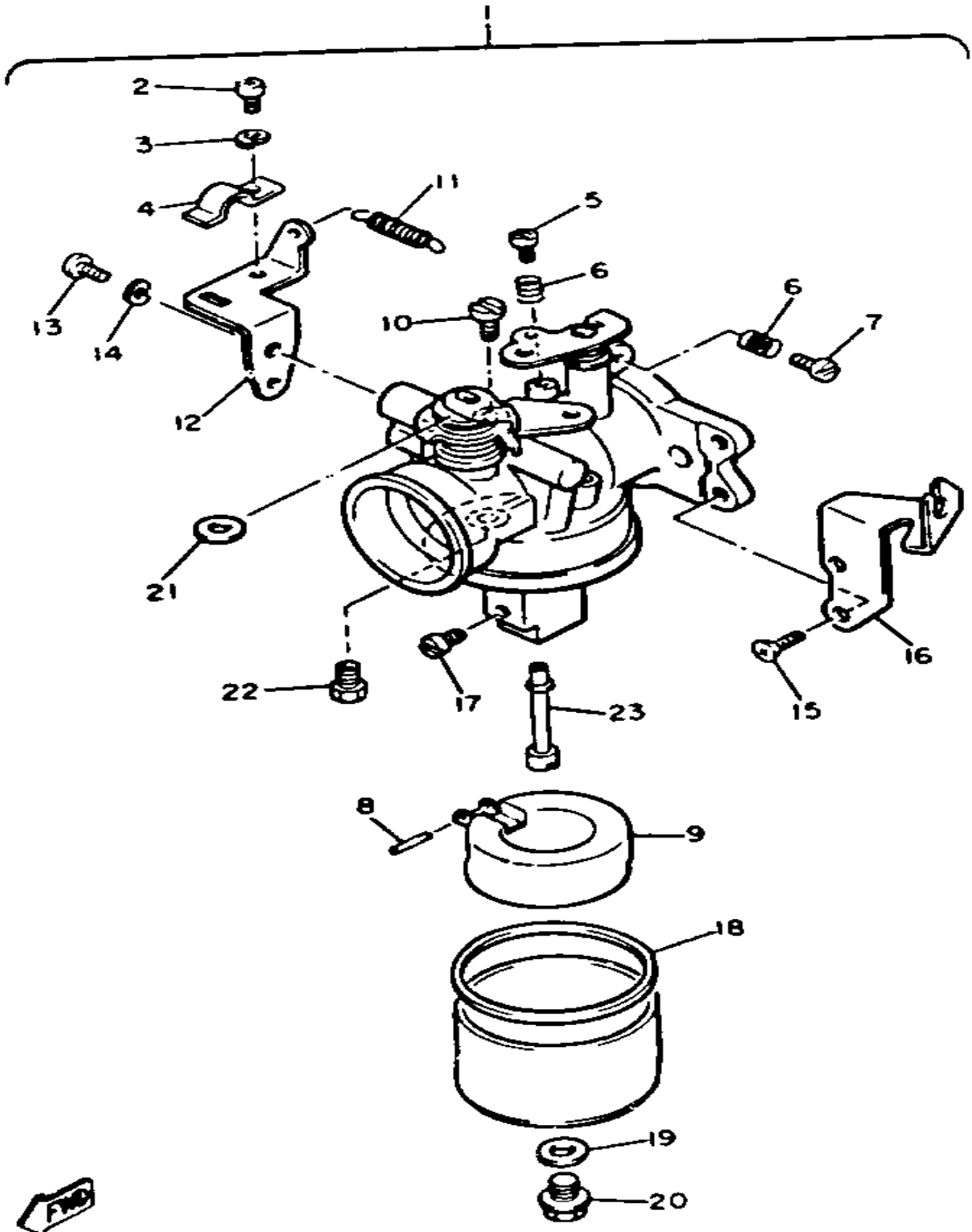

Ref. No.	Part Number	Description	Qty	Remarks
23	J38-14202-09-00	THROTTLE LEVER COMP 1	OPTIONAL PART
	J38-14218-00-00	SPRING, LOWER CHOKE 1	OPTIONAL PART
	J38-14589-00-00	SPRING, UPPER CHOKE 1	OPTIONAL PART

 J38110-5060

EXHAUST

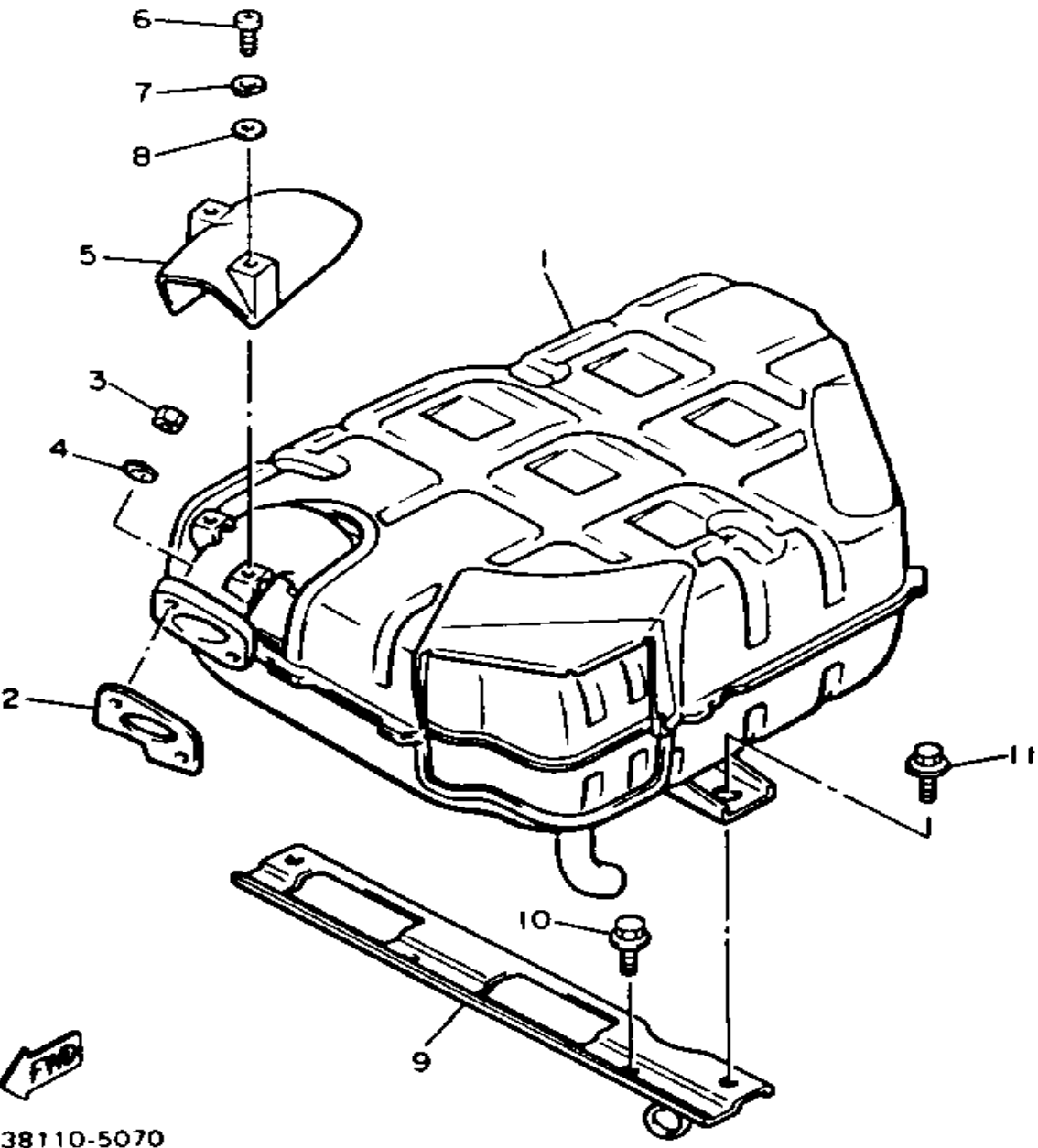

J38110-5070

Ref. No.	Part Number	Description	Qty	Remarks
1	J55-E4710-01-00	MUFFLER ASSEMBLY 1	1	
2	J38-14613-01-00	GASKET, EXHAUST PIPE	1	
3	95380-08600-00	NUT	2	
4	92990-08100-00	WASHER, PLAIN	2	
5	J38-14738-00-00	PROTECTOR, muffler 3	1	
6	98580-06012-00	SCREW, PAN HEAD (92501-06012-00)	2	
7	92995-06100-00	WASHER, SPRING (92990-06100-00)	2	
8	92990-06600-00	WASHER, PLATE	2	
9	J38-14771-00-00	STAY, MUFFLER 1	1	
10	95026-10020-00	BOLT, FLANGE	2	
11	90119-08119-00	BOLT, WITH WASHER	2	

CRANKCASE

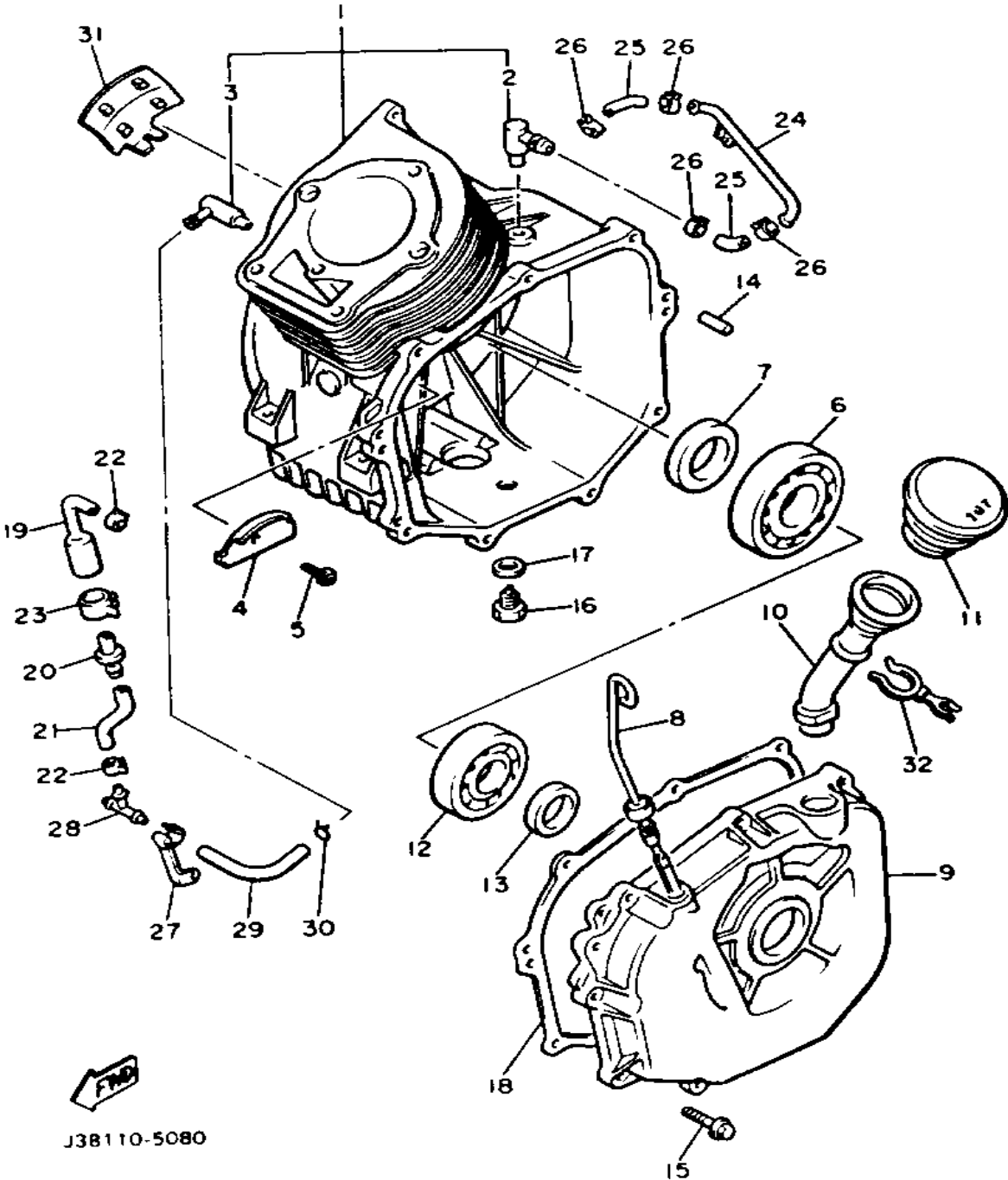

Ref. No.	Part Number	Description	Qty	Remarks
1	90387-155R3-00	. COLLAR	1	
	95021-10040-00	. BOLT, FLANGE	2	
	99999-01972-00	CRANKCASE ASS'Y (J38-15100-00)	1	
	J38-15100-02-00	. CRANKCASE ASSEMBLY	1	
2	J38-15148-00-00	. NOZZLE 2	1	
3	J38-15155-00-00	. NOZZLE 3	1	
4	J38-15123-00-00	PLATE, BUFFLE 1	1	
5	90159-05117-00	SCREW, W/WASHER (J38)	1	
6	93306-30709-00	BEARING	1	
7	93102-35191-00	OIL SEAL	1	
8	J38-15361-00-00	GAUGE, LEVEL	1	
9	90387-155R3-00	. COLLAR	1	
	99999-01974-00	COVER, crankcase 1	1	
	J38-15411-01-00	. COVER, CRANKCASE 1	1	
10	J38-15112-00-00	PIPE, OIL	1	
11	J38-15363-00-00	PLUG, OIL	1	
12	93306-30630-00	BEARING	1	
13	93102-30195-00	OIL SEAL	1	
14	93608-12063-00	PIN, DOWEL	2	
15	95811-08035-00	BOLT, FLANGE	9	
16	90340-12097-00	PLUG, STRAIGHT SCRW	1	
17	812-11198-00-00	GASKET	1	
18	J38-15451-00-00	GASKET, CRCS COVERCRANKCASE COVER 1	1	
19	J38-14388-00-00	VALVE, VACUUM CONTROL	1	
20	J38-13115-00-00	CONNECTOR, SUCTION PIPE	1	
21	90445-113E4-00	HOSE	1	
22	90467-10035-00	CLIP	2	

CONTINUED ON NEXT FRAME ►

CRANKCASE

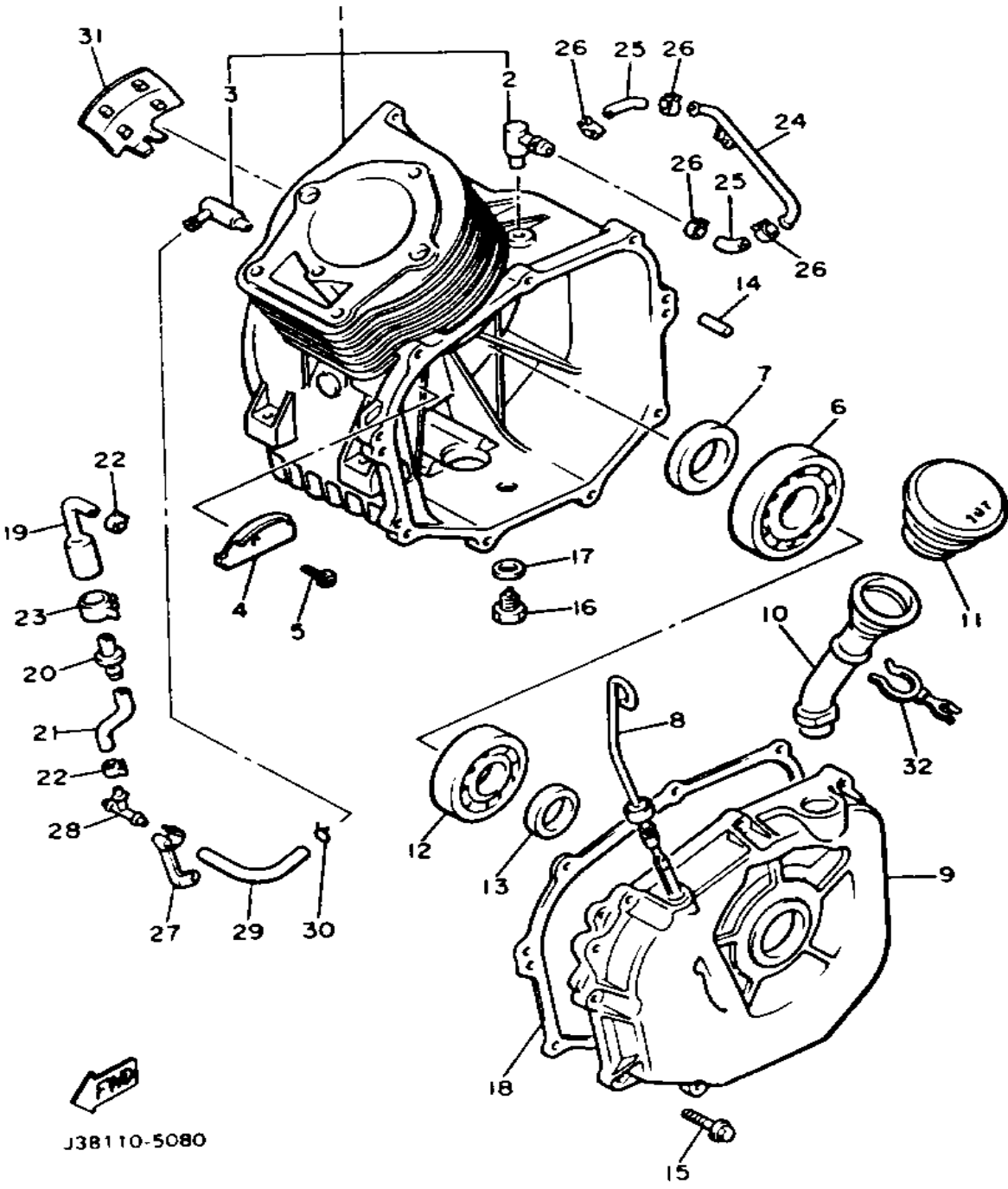

Ref. No.	Part Number	Description	Qty	Remarks
23	90468-08104-00	CLIP	1	
24	J38-13161-00-00	PIPE, DELIVERY 1	1	
25	90445-110E6-00	HOSE	2	
26	90467-10035-00	CLIP	4	
27	90465-10292-00	CLAMP	1	
28	807-24376-00-00	PIPE, JOINT 1	1	
29	90445-09066-00	HOSE	1	
	90445-09073-00	HOSE	1	
30	90467-08017-00	CLIP	2	
31	J38-11355-00-00	SEAL, CYLINDER 1	1	
32	90464-26114-00	CLAMP	1	

ENGINE BRACKET

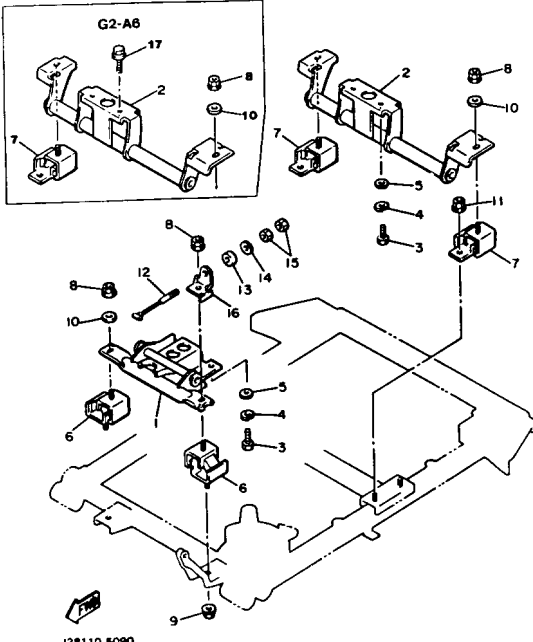

Ref. No.	Part Number	Description	Qty	Remarks
1	J38-21411-02-00	BRACKET, ENGINE 1	1	
2	J55-F1419-00-00	BRACKET, ENGINE 2	1	
3	97011-10025-00	BOLT	4	
4	92990-10100-00	WASHER, SPRING	4	
5	92990-10600-00	WASHER	4	
6	J38-21486-00-00	DAMPER 2	2	
7	J38-21488-00-00	DAMPER	2	
8	90185-10115-00	NUT, SELF-LOCKING	4	
9	95701-10500-00	NUT, FLANGE	2	
10	90201-10136-00	WASHER, PLATE	3	
11	95601-08200-00	NUT, SELF LOCKING	4	
12	J31-2217J-01-00	TENSIONER 1	1	
13	J17-2214F-00-00	DAMPER 1	1	
14	90201-06778-00	WASHER, PLATE	1	
15	95380-06600-00	NUT (95303-06600)	2	
16	J38-2141A-00-00	BRACKET 1	1	
17	95021-10040-00	BOLT, FLANGE	2	

REAR SHOCKS

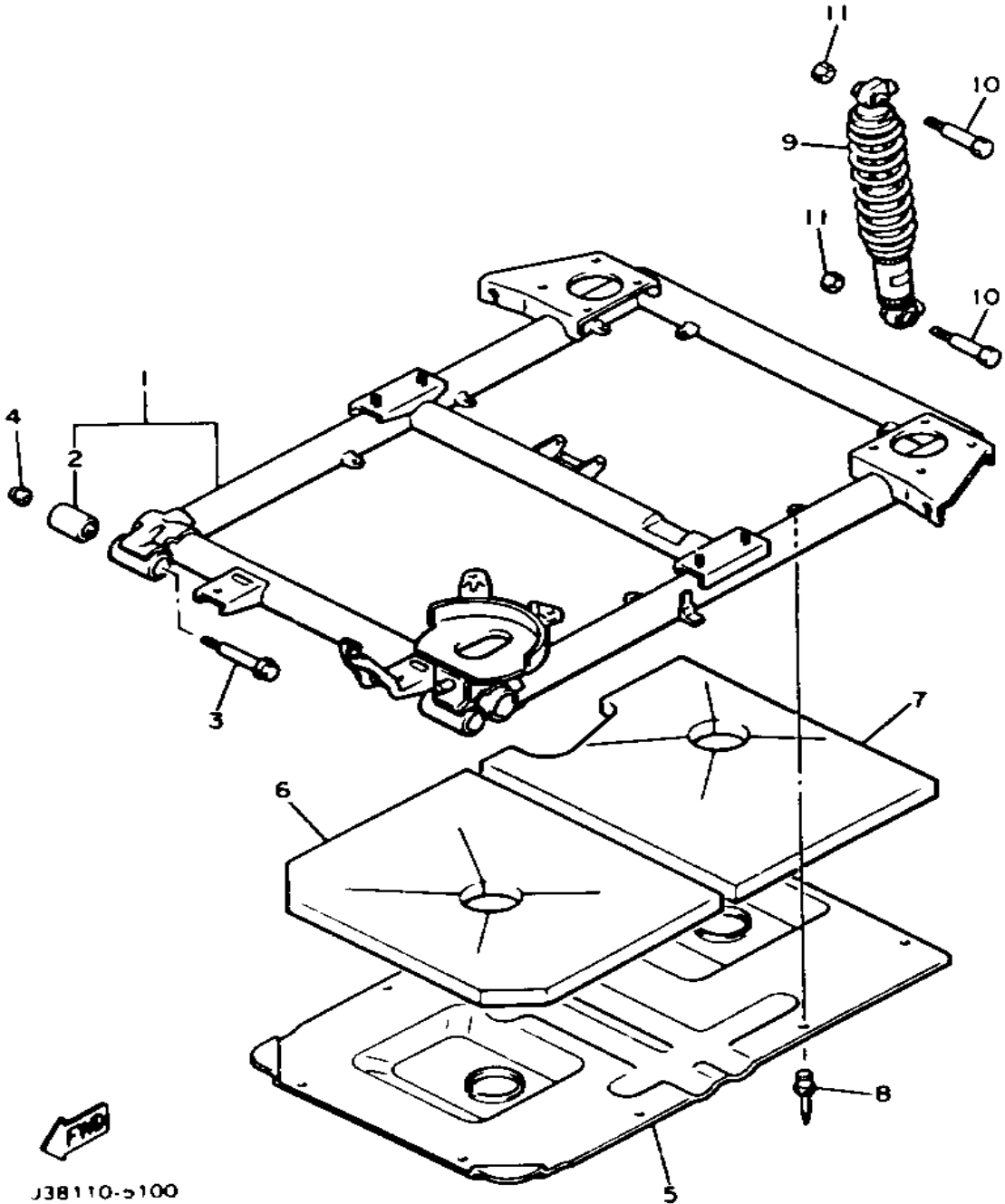

Ref. No.	Part Number	Description	Qty	Remarks
1	J55-F2110-W0-00	REAR ARM COMP.	1	
2	J10-22123-00-00	. BUSH 1	2	
3	90105-10359-00	BOLT, WASHER BASED	2	
4	90185-10115-00	NUT, SELF-LOCKING	2	
5	J38-22128-00-00	COVER, THRUST 1	1	
6	J55-F211E-00-00	PANEL, INNER 1	1	
7	J55-F211G-00-00	PANEL, INNER 2	1	
8	90267-40127-00	RIVET, BLIND	9	
9	JG5-F2210-00-00	SHOCK ABSORBER ASSEMBLY,	2	
10	97313-10050-00	BOLT, HEXAGON (676)	4	
11	95601-10100-00	NUT, U (95602-10100-00)	4	

J38110-5100

FRAME

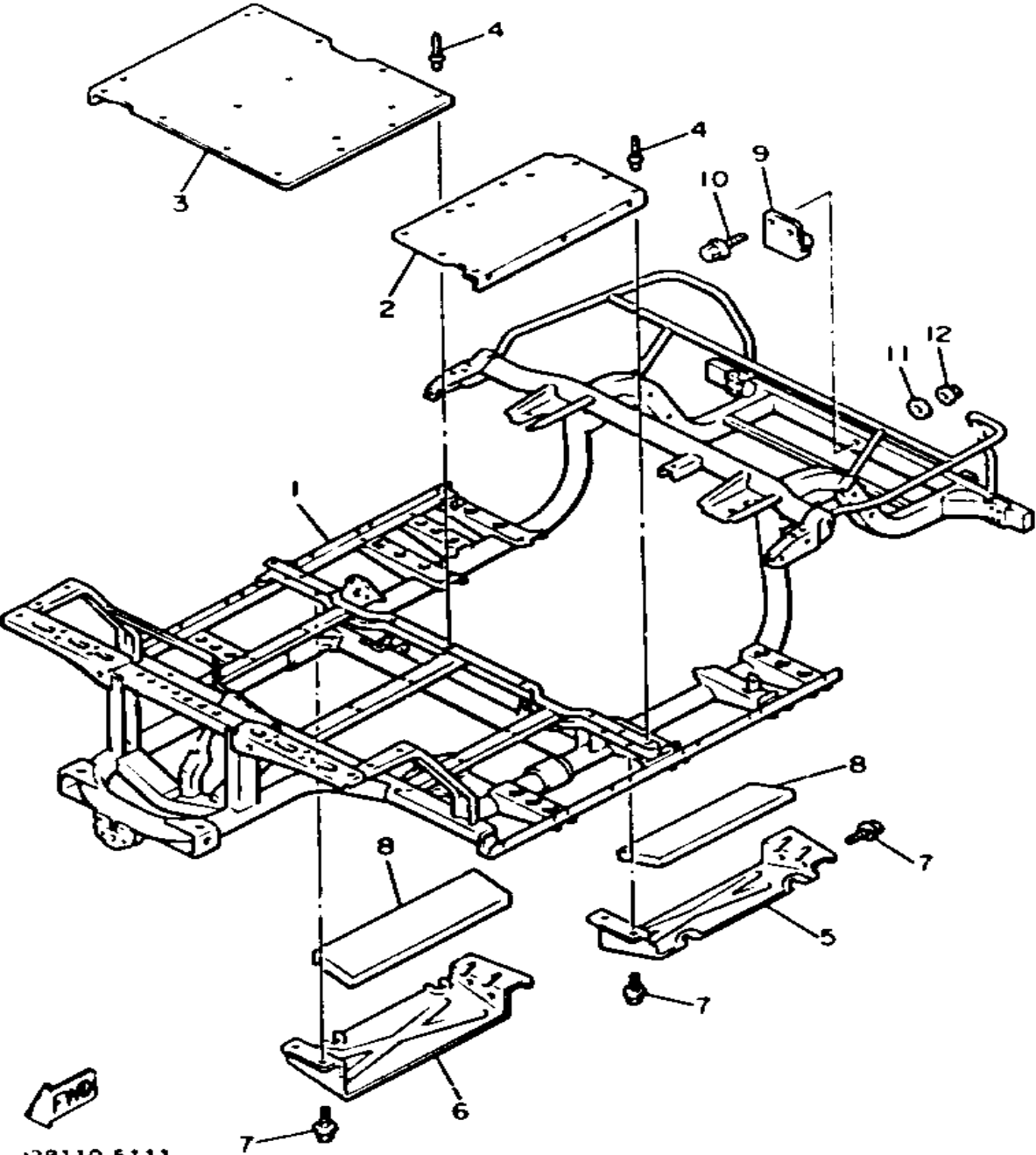

Ref. No.	Part Number	Description	Qty	Remarks
1	J55-F2501-00-00	FRAME	1	
2	J55-F2571-00-00	PANEL 1	1	
3	J55-F2572-00-00	PANEL 2	1	
4	90267-40054-00	RIVET, BLIND	20	
5	J38-22592-00-00	PLATE 1	1	
6	J38-22593-00-00	PLATE 2	1	
7	95811-06010-00	BOLT, FLANGE	8	
8	J55-K825H-00-00	PAD, SILENCER 4	2	
9	ABA-JF286-00-00	REAR HITCH	1	
10	95811-08050-00	BOLT, FLANGE (95823-08050)	2	
11	90201-08730-00	WASHER, PLATE	2	
12	95701-08500-00	NUT, FLANGE (95702-08500)	2	

J38110-5111

FRONT SUSPENSION - WHEEL

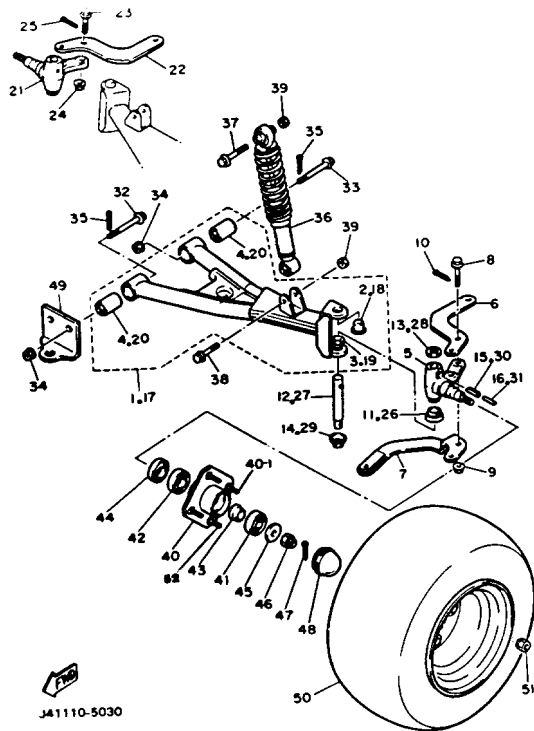

Ref. No.	Part Number	Description	Qty	Remarks
1	J38-23507-01-00	FRONT LOWER ARM SUB-ASS'Y (L.H) (J38-23507-00)	1	
2	90338-17225-00	. PLUG	1	
3	90386-15139-00	. BUSH	1	
4	J38-23526-00-00	. BUSH	1	
	J38-23526-00-00	. BUSH	2	
5	J38-23511-01-00	KNUCKLE, STEERING 1	1	
6	J38-23512-02-00	ARM, KNUCKLE 1	1	
7	ABA-JF288-00-00	ARM, STEERING (J41-23532-00)	1	
8	90105-10366-00	BOLT, WASHER BASED	2	
9	90185-10115-00	NUT, SELF-LOCKING	1	
	90185-10115-00	NUT, SELF-LOCKING	2	
10	91401-25020-00	PIN, COTTER	1	
	91401-25020-00	PIN, COTTER	2	
11	J38-23527-00-00	SEAL, DUST	1	
12	J38-23516-00-00	PIN, STEERING KNUCKLE	1	
13	90201-156J2-00	WASHER, PLAIN	1	
14	J38-23528-00-00	SEAL, DUST	1	
15	91609-60028-00	PIN, SPRING	1	
16	91609-35028-00	PIN, SPRING	1	
17	J38-23508-01-00	FRONT LOWER ARM SUB-ASS'Y (R.H) (J38-23508-00)	1	
18	90338-17225-00	. PLUG	1	
19	90386-15139-00	. BUSH	1	
20	J38-23526-00-00	. BUSH	1	
	J38-23526-00-00	. BUSH	2	
21	J38-23521-01-00	KNUCKLE, STEERING 2	1	
22	J38-23512-02-00	ARM, KNUCKLE 1	1	
23	90105-10360-00	BOLT, FLANGE	1	

CONTINUED ON NEXT FRAME ►

FRONT SUSPENSION - WHEEL

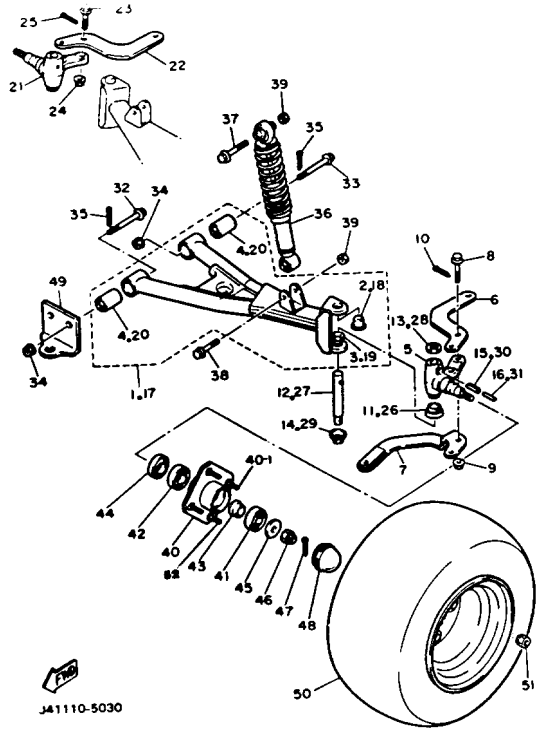

Ref. No.	Part Number	Description	Qty	Remarks
23	90105-10360-00	BOLT, FLANGE	2	
24	90185-10115-00	NUT, SELF-LOCKING	1	
	90185-10115-00	NUT, SELF-LOCKING	2	
25	91401-25020-00	PIN, COTTER	1	
	91401-25020-00	PIN, COTTER	2	
26	J38-23527-00-00	SEAL, DUST	1	
27	J38-23516-00-00	PIN, STEERING KNUCKLE ...	1	
28	90201-156J2-00	WASHER, PLAIN	1	
29	J38-23528-00-00	SEAL, DUST	1	
30	91609-60028-00	PIN, SPRING	1	
31	91609-35028-00	PIN, SPRING	1	
32	90105-10358-00	BOLT, WASHER BASED	2	
33	90105-10357-00	BOLT, FLANGE	2	
	90105-10357-00	BOLT, FLANGE	4	
34	90185-10115-00	NUT, SELF-LOCKING	4	
35	91401-25020-00	PIN, COTTER	4	
36	JG5-F3350-00-00	SHOCK ABSORBER ASSEMBLY	2	
37	97002-10065-00	BOLT	2	
38	97313-10050-00	BOLT, HEXAGON (676)	2	
39	95601-10100-00	NUT, U (95602-10100-00)	4	
40	J38-W2511-00-00	HUB, FRONT	2	
41	93306-20437-00	BEARING	2	
42	93306-00511-00	BEARING	2	
43	90387-241M7-00	COLLAR	2	
44	93102-30083-00	SEAL, OIL	2	
45	90209-32271-00	WASHER	2	
46	95601-14100-00	NUT, U (95602-14100-00)	2	
47	91401-25020-00	PIN, COTTER	2	

CONTINUED ON NEXT FRAME ►

FRONT SUSPENSION - WHEEL

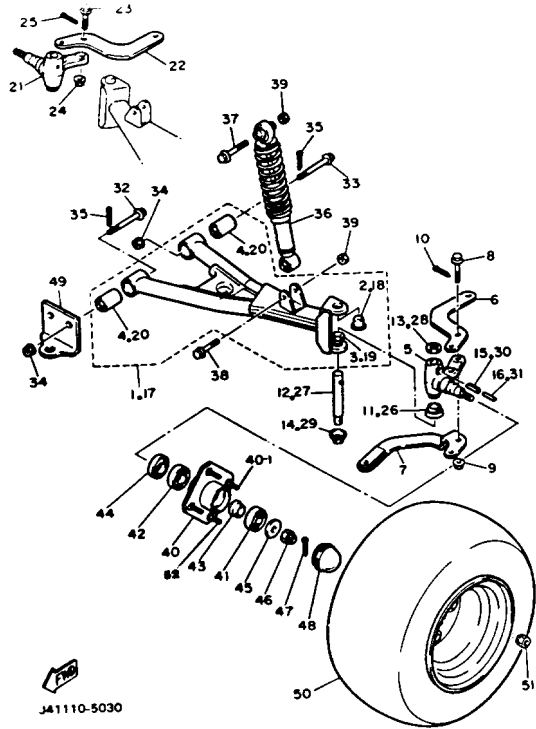

Ref. No.	Part Number	Description	Qty	Remarks
48	J17-25118-00-00	COVER, HUB DUST	2	
49	ABA-JF287-00-00	BRACKET 1 ASSEMBLY	1	
50	J55-F5100-00-00	FRONT WHEEL ASSEMBLY ..	2	
51	90179-12262-00	NUT	8	
40-1	90114-12003-00	. BOLT, RIBBED NECK	8	

STEERING

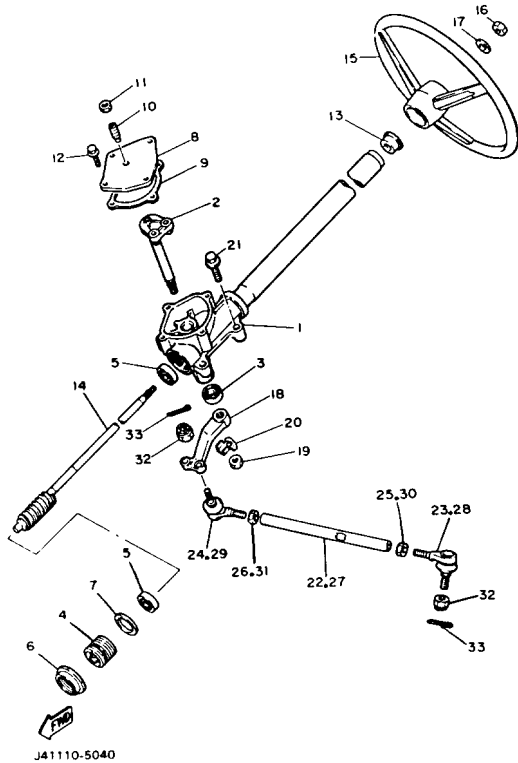

Ref. No.	Part Number	Description	Qty	Remarks
1	J55-F3811-00-00	COLUMN, STEERING (J38-23811-00)	1	
2	J38-23816-00-00	ARM, PITMAN	1	
3	93102-22087-00	OIL SEAL	1	
4	J55-F3876-00-00	BOLT	1	
5	93332-00010-00	BEARING	2	
6	J10-23877-00-00	NUT	1	
7	J10-23444-00-00	WASHER	1	
8	J55-23818-00-00	COVER, STEERING	1	
9	J38-23462-00-00	SEAL, STEERING (J38-23462-01-00)	1	
10	J10-23459-00-00	BOLT	1	
11	90170-08024-00	NUT, HEX.	1	
12	95811-06020-00	BOLT, FLANGE	4	
13	J38-23814-00-00	HOLDER, HANDLE UPPER	1	
14	J10-23840-00-00	STEERING SHAFT	1	
15	J55-F3838-00-00	WHEEL, STEERING (J10-23838-00)	1	
16	90185-12119-00	NUT, SELF-LOCKING	1	
17	92990-12200-00	WASHER, PLAIN	1	
18	J38-23826-01-00	ARM, IDLER	1	
19	95701-16300-00	NUT, FLANGE	1	
20	90215-16161-00	WASHER, LOCK	1	
	90215-16252-00	WASHER, TONGUE	1	
21	95811-10050-00	BOLT, FLANGE (95822-10050)	4	
22	J38-23831-02-00	ROD, TIE	1	106~ 066200
	J38-23831-02-00	ROD, TIE	1	201~
23	J38-23841-00-00	JOINT, universal 1 0 1	1	106~ 066200
	J38-23841-01-00	JOINT, UNIVERSAL 1	1	201~
24	J38-23845-00-00	JOINT, universal 2 0 1	1	106~ 066200

CONTINUED ON NEXT FRAME ➤

STEERING

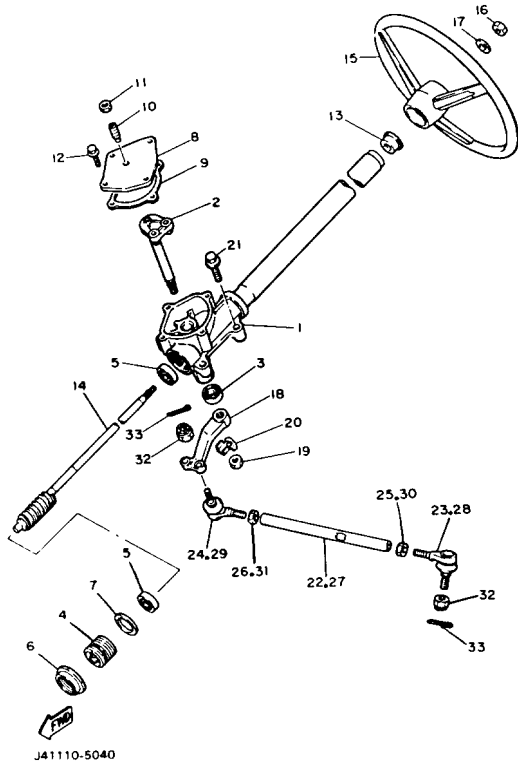

Ref. No.	Part Number	Description	Qty	Remarks
24	J38-23845-01-00	JOINT, UNIVERSAL 2	1	201~
25	90170-12055-00	NUT	1	201~
	95303-10700-00	NUT	1	106~ 066200
26	90170-10186-00	NUT	1	106~ 066200
	90170-12054-00	NUT	1	201~
27	J38-23831-00-00	ROD, tie 0 1	1	106~ 066200
	J38-23831-02-00	ROD, TIE	1	201~
28	J38-23841-00-00	JOINT, universal 1 0 1	1	106~ 066200
	J38-23841-01-00	JOINT, UNIVERSAL 1	1	201~
29	J38-23845-00-00	JOINT, universal 2 0 1	1	106~ 066200
	J38-23845-01-00	JOINT, UNIVERSAL 2	1	201~
30	90170-12055-00	NUT	1	201~
	95303-10700-00	NUT	1	106~ 066200
31	90170-10186-00	NUT	1	106 066200
	90170-12054-00	NUT	1	201~
32	95601-10100-00	NUT, U (95602-10100-00)	4	
33	91401-25020-00	PIN, COTTER	4	

FUEL TANK

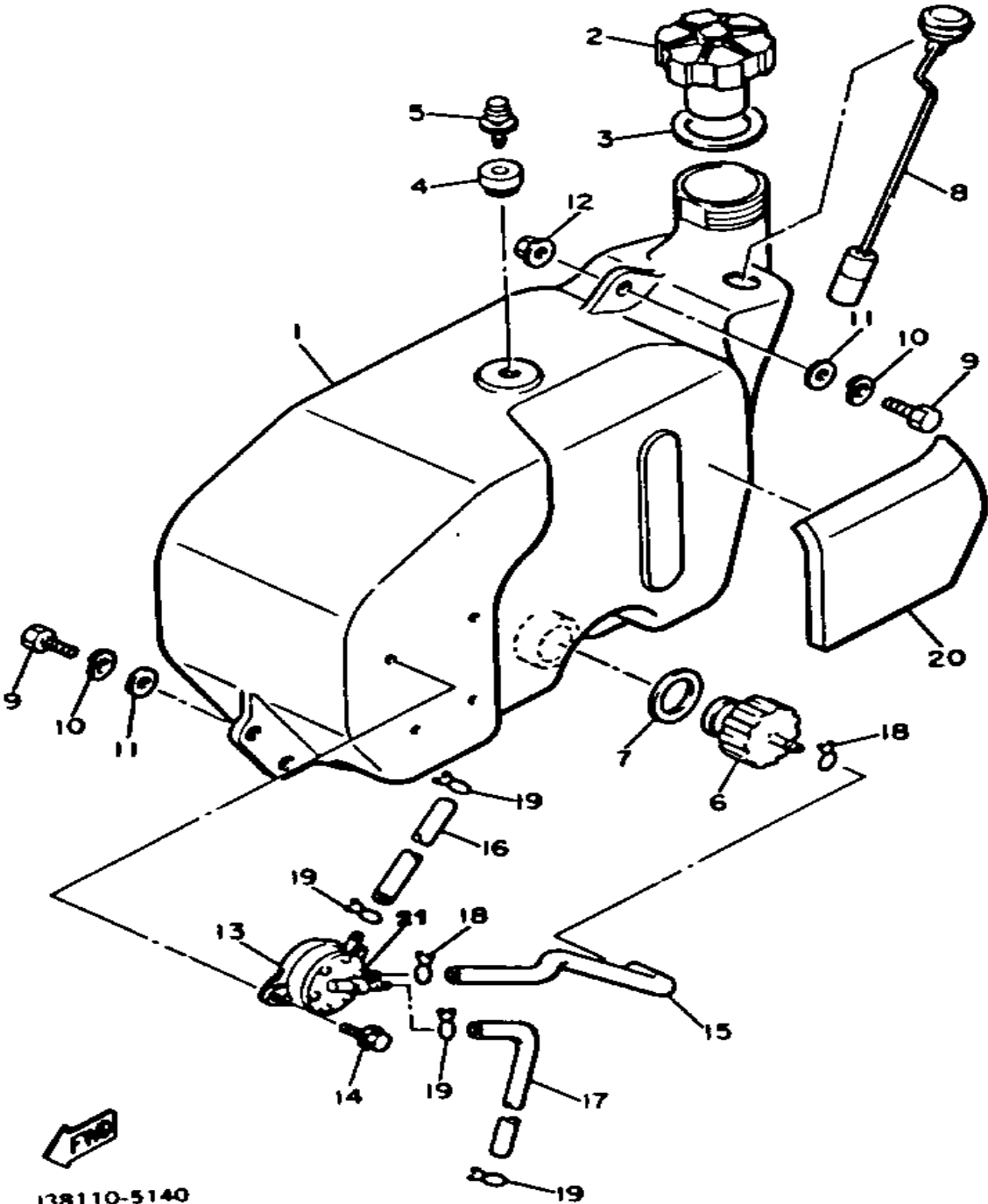

Ref. No.	Part Number	Description	Qty	Remarks
1	J55-F4111-00-00	FUEL TANK	1	
2	J24-24620-01-00	BODY CAP ASSEMBLY	1	
3	J10-24612-00-00	GASKET, CAP	1	
4	J10-21773-00-00	GROMMET	1	
5	J24-24460-01-00	RELEASE VALVE ASSEMBLY.	1	
6	8R4-24560-00-00	FILTER ASSEMBLY.	1	
7	8F3-24564-00-00	GASKET	1	
8	J38-85710-02-00	FUEL LEVEL GAUGE ASSEMBLY.	1	
9	97001-08025-00	BOLT (1NV)	3	
10	92990-08100-00	WASHER, PLAIN	3	
11	90201-08748-00	WASHER, PLATE	3	
12	95701-08500-00	NUT, FLANGE (95702-08500) ..	1	
13	J38-24410-10-00	FUEL PUMP ASSEMBLY	1	
14	95811-06016-00	BOLT, FLANGE (95801-06016) .	2	
15	J38-24311-00-00	PIPE, FUEL 1	1	
16	90445-09225-00	HOSE	1	
17	90445-09085-00	HOSE	1	
18	90467-11009-00	CLIP	2	
19	90467-08017-00	CLIP	4	
20	J55-F4129-00-00	COVER, SIDE 1 (J38-24129-00)	1	
21	J38-24452-18-00	COVER, FUEL PUMP	1	

J38110-5140

BRAKE 1

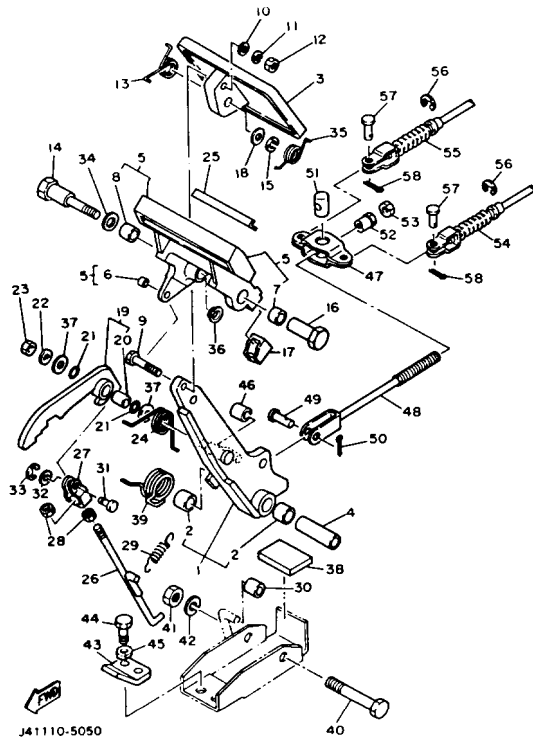

Ref. No.	Part Number	Description	Qty	Remarks
1	92990-10600-00	. WASHER	1	
	99080-07600-00	. CIRCLIP	1	
	99999-01757-00	BRAKE ARM CMLPT (J17-27250-01)	1	
2	90384-14080-00	. BUSH, BIMETAL	2	
3	J10-27211-00-00	PEDAL, BRAKE	1	
4	90387-107F8-00	COLLAR	1	
5	J17-25670-00-00	PARKING PEDAL COMP.	1	
6	90384-05163-00	. BUSH, BIMETAL	1	
7	90384-12164-00	. BUSH, BIMETAL	1	
8	90380-12051-00	. BUSH, SOLID	1	
9	90101-06555-00	BOLT, HEX.	1	
10	92990-06200-00	WASHER, PLAIN	1	
11	92995-06100-00	WASHER, SPRING (92990-06100-00)	1	
12	95380-06600-00	NUT (95303-06600)	1	
13	90508-23542-00	SPRING, TORSION	1	
14	90109-08669-00	BOLT	1	
15	92990-08100-00	WASHER, PLAIN	1	
16	90179-08378-00	NUT	1	
17	J17-25679-01-00	DAMPER	2	
18	92990-08200-00	WASHER, SPRING (92902-08100)	1	
19	J17-W2561-00-00	SECTOR, PARKING BRAKE ..	1	
20	90384-10162-00	. BUSH, BIMETAL	1	
21	J17-27221-00-00	SEAL, SHAFT	2	
22	90201-065F3-00	WASHER, PLATE	1	
23	95601-06100-00	NUT, U	1	
24	90508-14548-00	SPRING, TORSION	1	
25	J17-25672-00-00	PAD, PARKING PEDAL	1	

CONTINUED ON NEXT FRAME ►

BRAKE 1

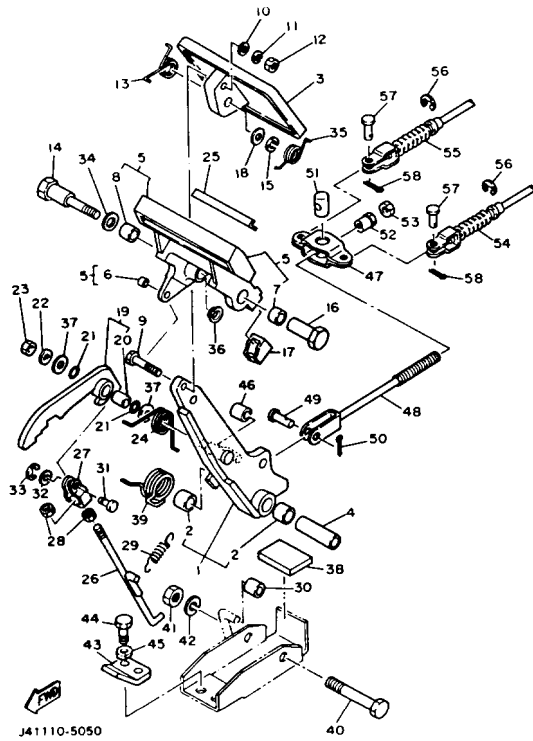

Ref. No.	Part Number	Description	Qty	Remarks
26	J17-27231-00-00	ROD, BRAKE	1	
27	J17-27232-00-00	END, ROD	1	
28	95380-06700-00	NUT (95303-06700-00)	2	
29	90506-12277-00	SPRING, TENSION	1	
30	J17-25673-00-00	DAMPER, BRAKE	1	
31	J17-27228-00-00	PIN, LINK JOINT	1	
32	92901-05600-00	WASHER, PLATE	1	
33	99080-04600-00	CIRCLIP (E)	1	
34	90201-123F2-00	WASHER, PLAIN	1	
35	90508-26557-00	SPRING, TORSION	1	
36	90380-12105-00	BUSH, SOLID	1	
37	90201-104G8-00	WASHER, PLAIN	2	
38	J17-27245-00-00	PAD, BRAKE PEDAL	1	
39	90508-40543-00	SPRING, TORSION	1	
40	90101-10447-00	BOLT, HEX.	1	
41	95601-10100-00	NUT, U (95602-10100-00)	1	
42	92990-10100-00	WASHER, SPRING	1	
43	J17-27246-00-00	NAIL, BRAKE	1	
44	97313-08020-00	BOLT, HEXAGON	2	
45	92990-08100-00	WASHER, PLAIN	2	
46	J17-25673-00-00	DAMPER, BRAKE	1	
47	J10-25681-00-00	EQUALIZER, BRAKE	1	
48	J20-25685-00-00	ROD	1	
49	91701-10022-00	PIN	1	
50	91490-30020-00	PIN, COTTER	1	
51	90249-14129-00	PIN	1	
52	90179-08261-00	NUT	1	
53	95303-08700-00	NUT	1	
54	J55-F6341-00-00	CABLE, BRAKE	1	

CONTINUED ON NEXT FRAME ➤

BRAKE 1

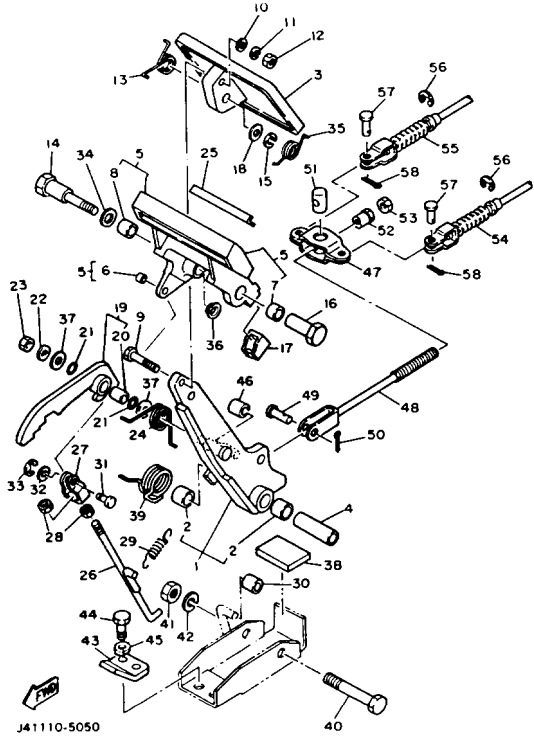

Ref. No.	Part Number	Description	Qty	Remarks
55	J55-F6351-00-00	CABLE, BRAKE	1	
56	99001-09600-00	CIRCLIP	4	
57	91701-08018-00	PIN	4	
58	91490-25020-00	PIN, COTTER	4	

BRAKE 2

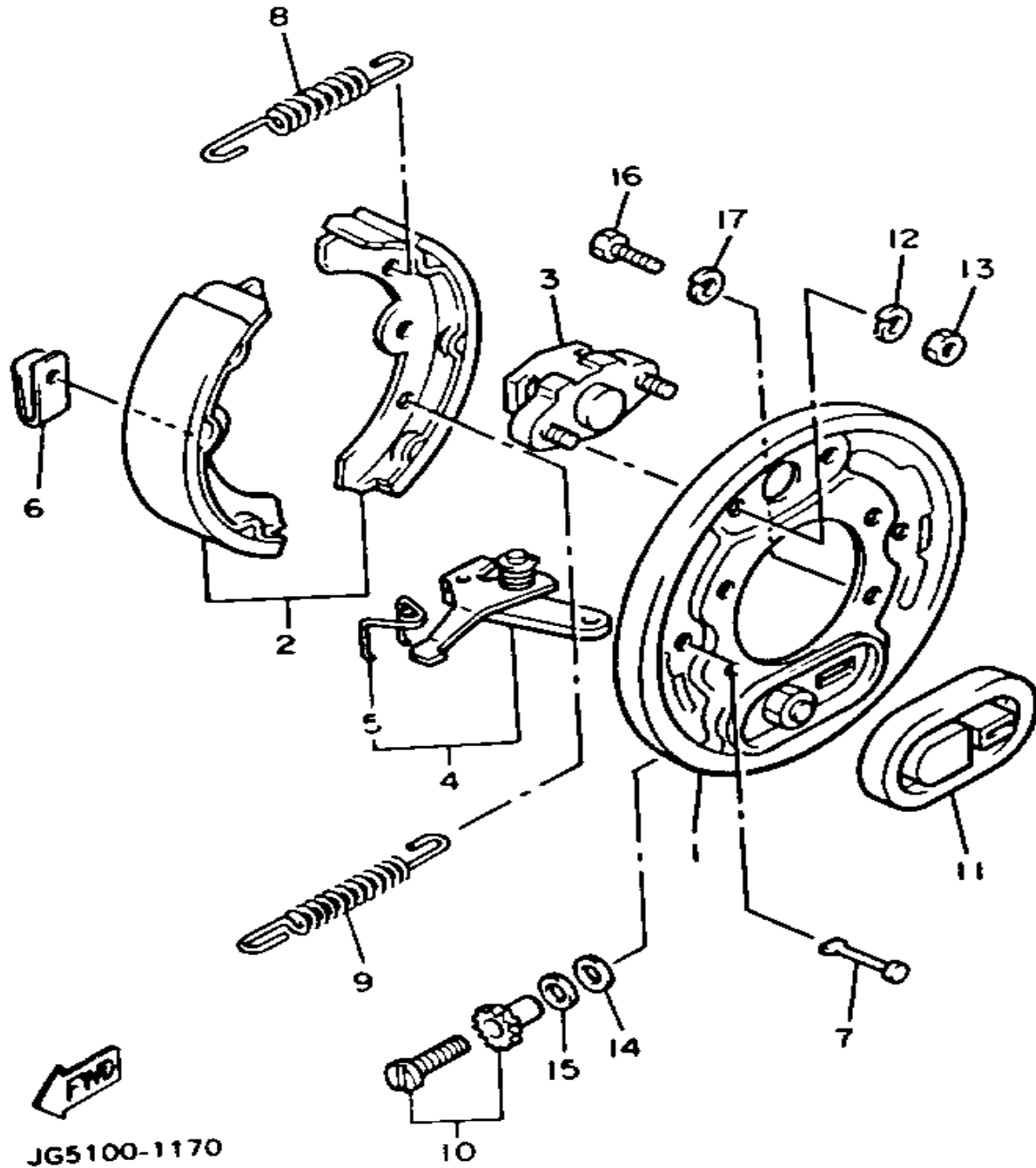

JG5100-1170

Ref. No.	Part Number	Description	Qty	Remarks
1	J17-27208-00-00	BACKING PLATE SUB ASSEMBLY 1 (R.H)	1	
2	J55-W2536-00-00	BRAKE SHOE SET	1	
3	J17-27206-00-00	ANCHOR BODY COMP.	1	
4	J38-27204-00-00	LEVER ASSEMBLY 1	1	
5	J55-25358-00-00	SPRING LEVER	1	
6	J10-27281-00-00	SPRING, SHOE CLAMP	2	
7	J10-27282-00-00	PIN, SHOE HOLD DOWN	2	
8	90506-20281-00	SPRING, TENSION	1	
9	90506-26191-00	SPRING, TENSION	1	
10	J55-27270-00-00	ADJUSTER ASSEMBLY	1	
11	J10-27286-00-00	COVER, DUST	1	
12	92995-06100-00	WASHER, SPRING (92990-06100-00)	2	
13	95380-06600-00	NUT (95303-06600)	1	
14	90201-121H8-00	WASHER, PLATE	1	
15	90201-121H9-00	WASHER, PLATE	1	
16	97011-08016-00	BOLT	4	
17	92990-08100-00	WASHER, PLAIN	4	

BRAKE 3

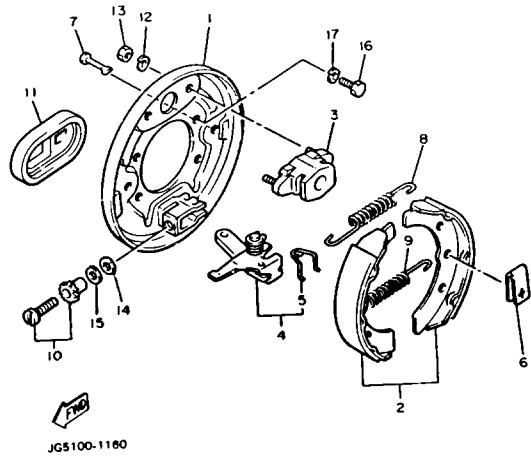

Ref. No.	Part Number	Description	Qty	Remarks
1	J17-27209-00-00	BACKING PLATE SUB ASSEMBLY 2 (L.H)	1	
2	J55-W2536-00-00	BRAKE SHOE SET	1	
3	J17-27206-00-00	ANCHOR BODY COMP.	1	
4	J38-27205-00-00	LEVER ASSEMBLY 2	1	
5	J55-25357-00-00	. SPRING, LEVER	1	
6	J10-27281-00-00	SPRING, SHOE CLAMP	2	
7	J10-27282-00-00	PIN, SHOE HOLD DOWN	2	
8	90506-20281-00	SPRING, TENSION	1	
9	90506-26191-00	SPRING, TENSION	1	
10	J55-27260-00-00	ADJUSTER ASSEMBLY	1	
11	J10-27286-00-00	COVER, DUST	1	
12	92995-06100-00	WASHER, SPRING (92990-06100-00)	2	
13	95380-06600-00	NUT (95303-06600)	2	
14	90201-121H8-00	WASHER, PLATE	1	
15	90201-121H9-00	WASHER, PLATE	1	
16	97011-08016-00	BOLT	4	
17	92990-08100-00	WASHER, PLAIN	4	

ACCELERATOR

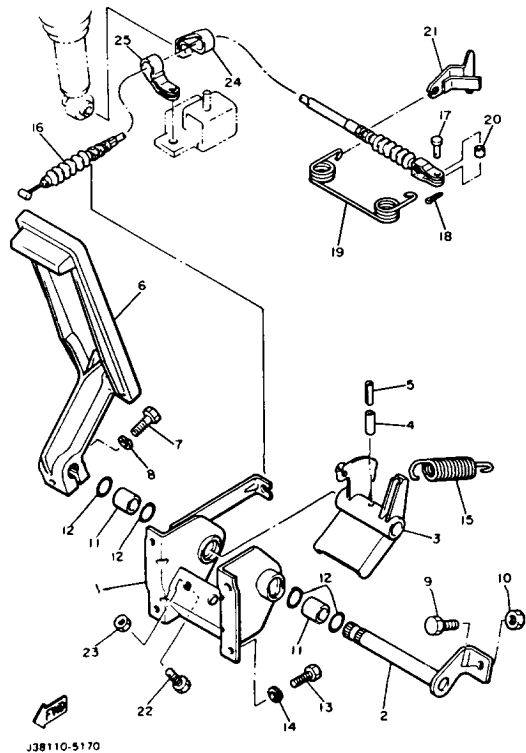

Ref. No.	Part Number	Description	Qty	Remarks
1	J38-27874-00-00	BRACKET, ACCELERATOR PEDAL	1	
2	J17-27853-00-00	SHAFT, PEDAL 1	1	
3	J38-27872-00-00	ARM, ACCELERATOR	1	
4	91609-60028-00	PIN, SPRING	1	
5	91609-35028-00	PIN, SPRING	1	
6	JF3-27871-00-00	PEDAL, ACCELERATOR	1	
7	97011-06025-00	BOLT (97001-06025)	1	
8	92995-06100-00	WASHER, SPRING (92990-06100-00)	1	
9	90106-08040-00	BOLT, RD. HEX	1	
10	95303-08700-00	NUT	1	
11	90384-14080-00	BUSH, BIMETAL	2	
12	93210-14104-00	O-RING	4	
13	97313-06016-00	BOLT, HEXAGON	4	
14	92995-06100-00	WASHER, SPRING (92990-06100-00)	4	
15	90506-26282-00	SPRING, TENSION	1	
16	J55-F6311-00-00	CABLE, THROTTLE 1	1	
17	91702-05012-00	PIN	1	
18	90468-10050-00	CLIP	1	
19	90508-16460-00	SPRING, TORSION	1	
20	90560-05001-00	SPACER	1	
21	J38-27981-00-00	BRACKET, THROTTLE	1	
22	97011-06025-00	BOLT (97001-06025)	1	
23	95380-06700-00	NUT (95303-06700-00)	1	
24	90461-08048-00	CLAMP	1	
25	90461-08106-00	CLAMP	1	

GOVERNOR

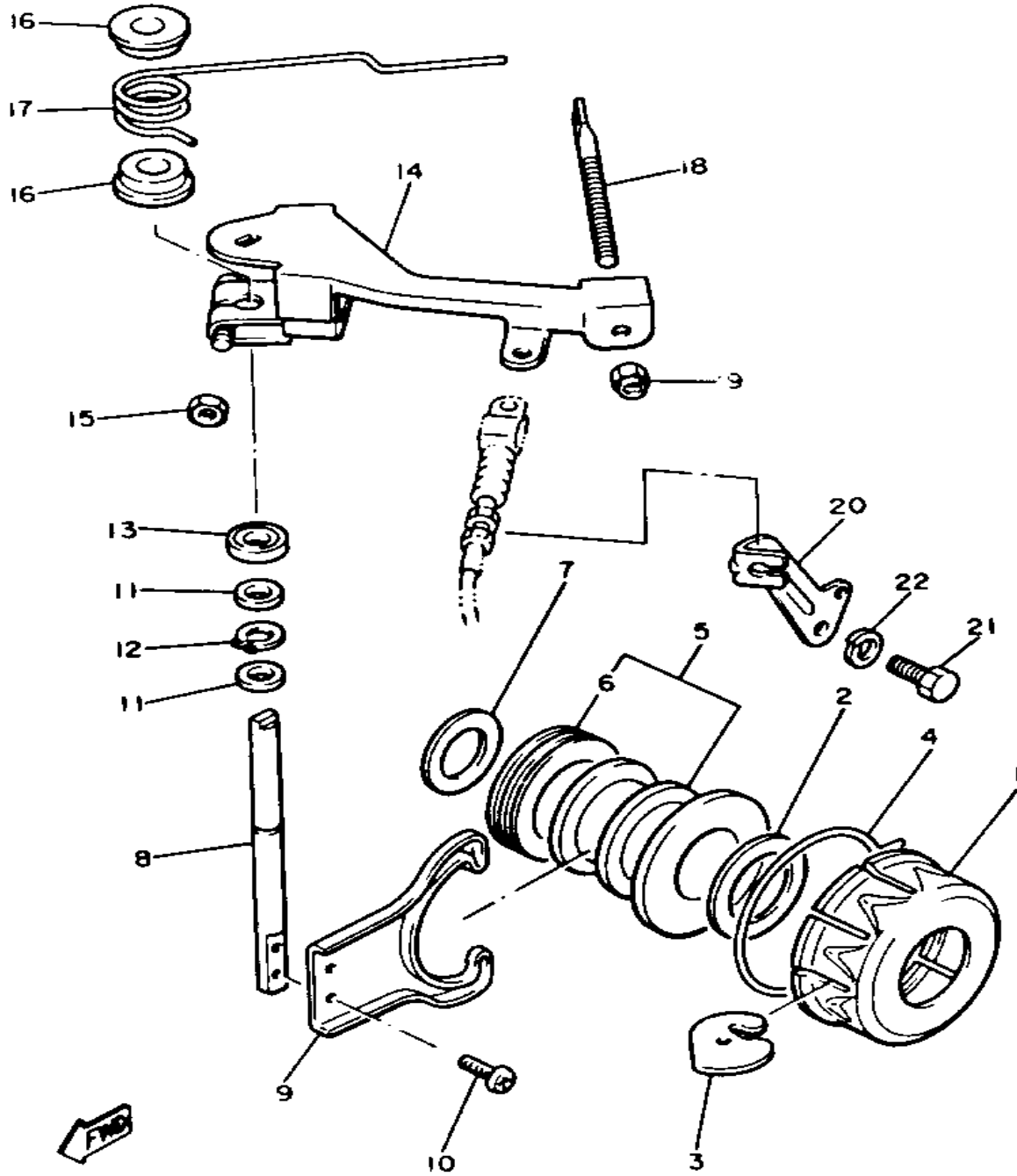

J38110-5180

Ref. No.	Part Number	Description	Qty	Remarks
1	J10-27912-00-00	RETAINER	1	
2	90387-21690-00	COLLAR	1	
3	J10-27913-00-00	WEIGHT	12	
4	J10-27911-00-00	HOLDER	1	
5	J10-27927-00-00	LIFTER	1	
6	93342-22502-00	. BEARING, THRUST	1	
7	90201-20275-00	WASHER, PLATE	1	
8	J38-27921-00-00	SHAFT, GOVERNOR	1	
9	J10-27922-00-00	FORK, GOVERNOR	1	
10	98580-04008-00	SCREW, PAN HEAD (98501-04008-00)	2	
11	90202-08110-00	WASHER, PLATE	2	
12	99009-06600-00	CIRCLIP	1	
13	93109-08050-00	OIL SEAL	1	
14	J38-27951-00-00	LEVER, SPEED	1	
15	95380-06600-00	NUT (95303-06600)	1	
16	90386-08141-00	BUSH	2	
17	90508-40678-00	SPRING, TORSION	1	
18	J38-27959-00-00	SCREW, ADJUSTING	1	
19	95701-06300-00	NUT, NYLON	1	
20	J38-27982-00-00	BRACKET, WIRE	1	
21	97022-08016-00	BOLT	1	
22	92990-08100-00	WASHER, PLAIN	1	

PRIMARY SHEAVE

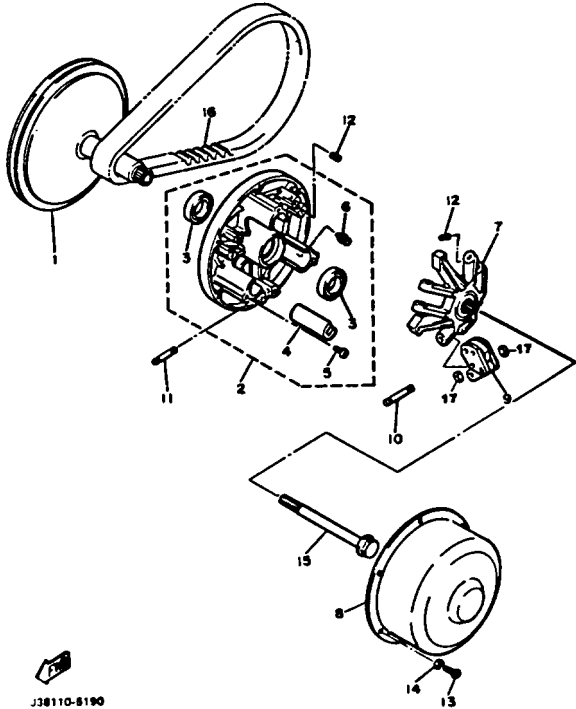

Ref. No.	Part Number	Description	Qty	Remarks
1	J38-46210-00-00	PRIMARY FIXED	1	
2	J38-46220-00-00	PRIMARY SLIDING SHEAVE COMP.	1	
3	93102-28348-00	. OIL SEAL	2	
4	J38-46253-00-00	. SLIDER	3	
5	98901-05008-00	. SCREW, BIND	3	
6	93700-06004-00	. NIPPLE, GREASE	1	
7	J38-46251-00-00	SPIDER	1	
8	J38-46231-00-00	CAP	1	
9	99999-01830-00	WGHT LINK KIT-G2A (J38-46205-00)	3	
10	J38-46236-00-00	PIN, WEIGHT	3	
11	J38-46237-00-00	PIN, WEIGHT 2	3	
12	90113-04050-00	BOLT, SET	12	
13	98501-05010-00	SCREW, PAN HEAD	6	
14	92990-05100-00	WASHER, SPRING	6	
15	J38-46249-00-00	BOLT	1	
16	J55-G6241-00-00	BELT	1	
17	90202-07164-00	WASHER, PLATE	6	

SECONDARY SHEAVE

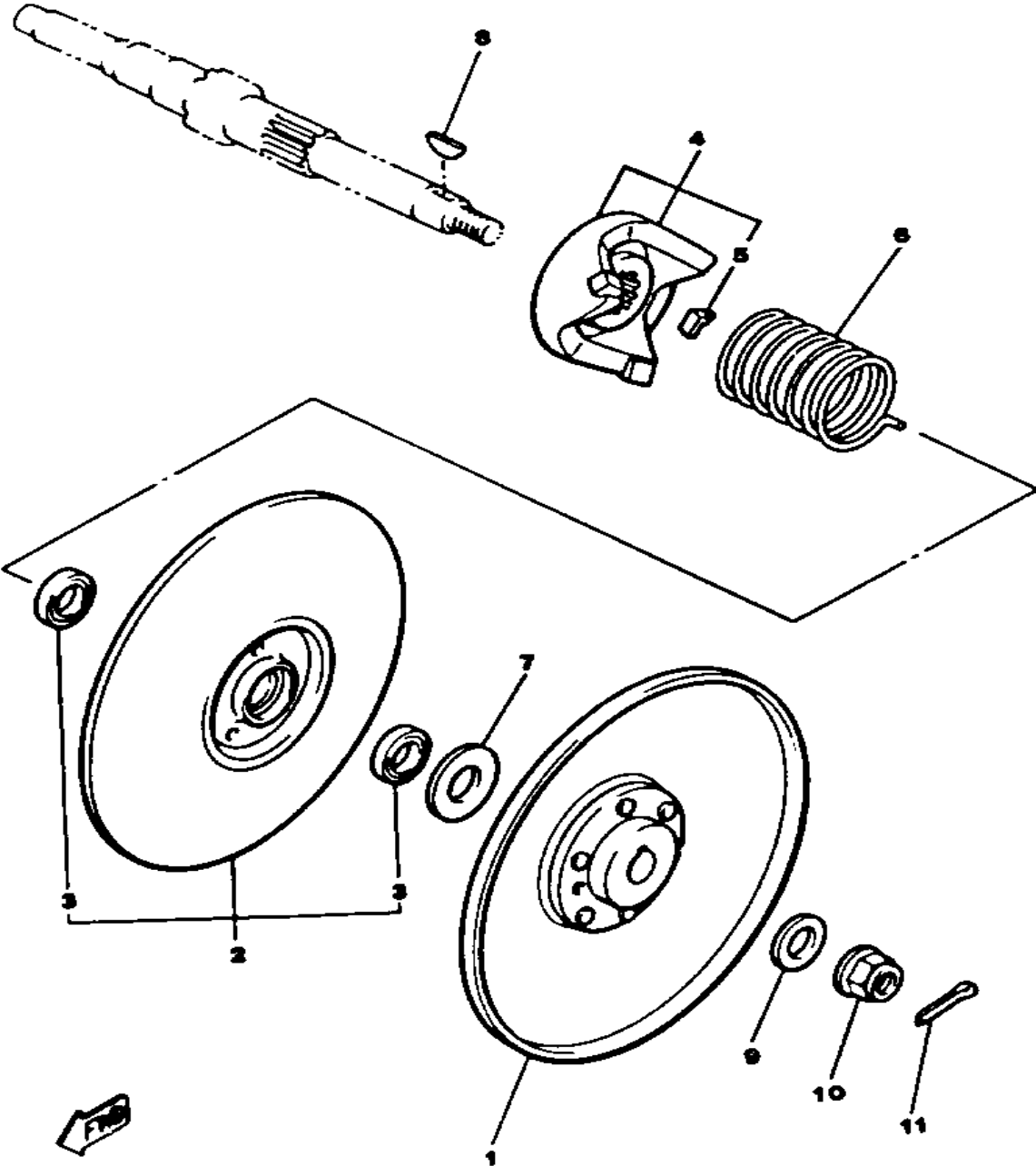

Ref. No.	Part Number	Description	Qty	Remarks
1	J55-G6260-00-00	SECONDARY FIXED SHEAVE COMP.	1	
2	J55-G6270-02-00	SECONDARY SLIDING SHEAVE COMP.	1	
3	93102-20309-00	. OIL SEAL	2	
4	J55-G6280-00-00	SEC SPRNG SEAT CMP (J38-46280-00)	1	
5	801-17688-10-00	SHOE, RAMP	1	
6	90508-45679-00	SPRING, TORSION	1	
7	90202-20130-00	WASHER, PLAIN	1	
8	90280-05022-00	KEY, WOODRUFF	1	
9	90201-12588-00	WASHER, PLATE	1	
10	95601-12200-00	NUT, SELF-LOCKING	1	
11	91401-25030-00	PIN, COTTER	1	

TRANSMISSION

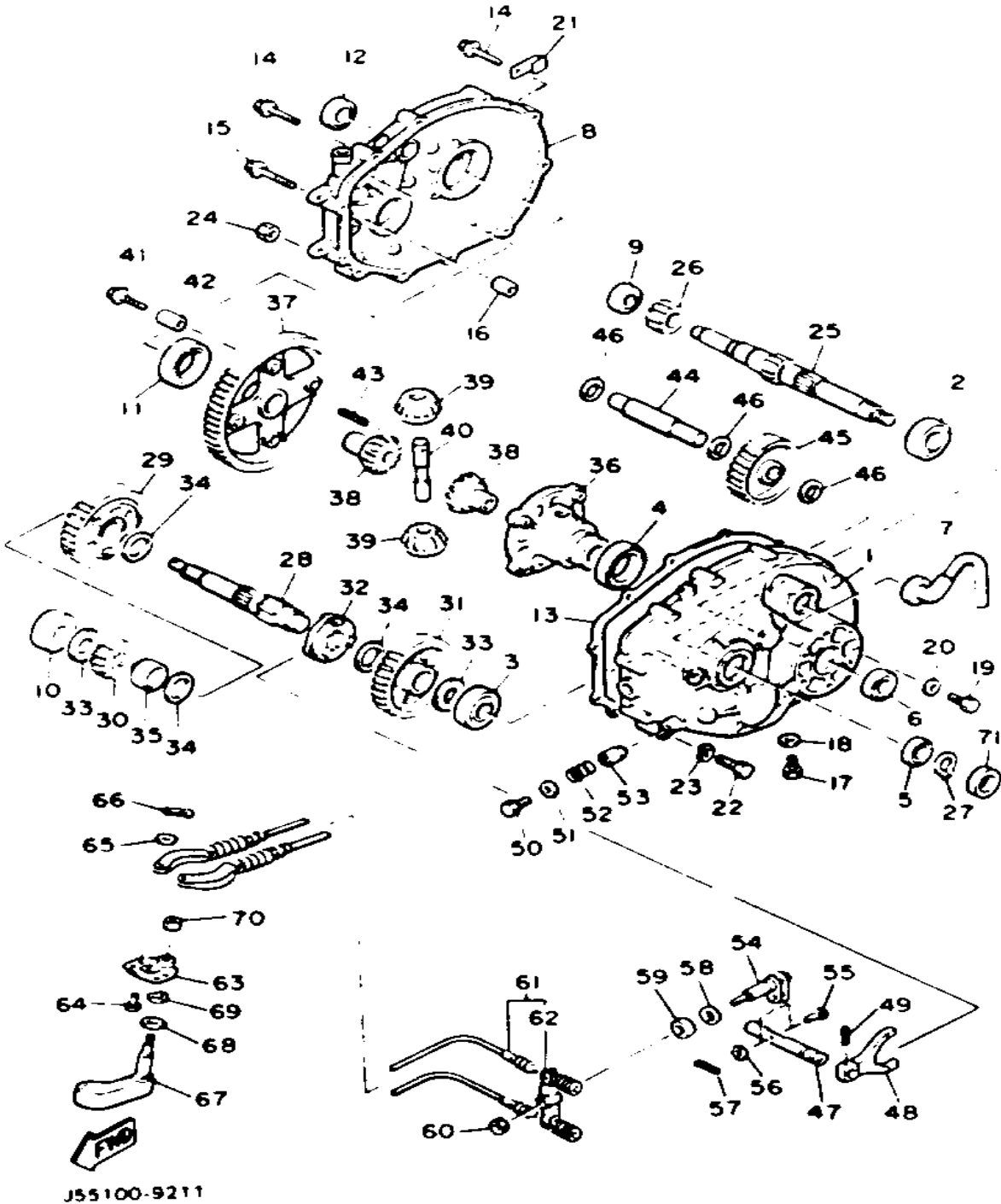

Ref. No.	Part Number	Description	Qty	Remarks
1	J38-46311-00-00	CASE, TRANSMISSION 1	1	
2	93306-20541-00	BEARING (B6205)	1	
3	93306-20421-00	BEARING (B6204)	1	
4	93306-00803-00	BEARING (B6008)	1	
5	93102-25017-00	OIL SEAL, SD-TYPE	1	
6	93102-22189-00	OIL SEAL	1	
7	835-47559-00-00	CAP 2	1	
8	J38-46312-00-00	CASE, TRANS 2	1	
9	93306-20324-00	BEARING	1	
10	93306-20421-00	BEARING (B6204)	1	
11	93306-00803-00	BEARING (B6008)	1	
12	93102-22189-00	OIL SEAL	1	
13	J38-46319-01-00	GASKET	1	
14	95811-08040-00	BOLT, FLANGE	8	
15	95811-08050-00	BOLT, FLANGE (95823-08050)	2	
16	99510-12016-00	PIN, DOWEL	2	
17	90340-14036-00	PLUG, STRAIGHT SCREW	1	
18	90430-14043-00	GASKET	1	
19	90101-08344-00	BOLT	1	
20	90201-08087-00	WASHER, PLATE	1	
21	90465-06100-00	CLAMP	1	
22	97013-08075-00	BOLT	1	
23	92990-08100-00	WASHER, PLAIN	1	
24	95303-08600-00	NUT	1	
25	J38-46321-02-00	SHAFT, INPUT	1	
26	J38-46331-01-00	GEAR, INPUT 1	1	
27	93410-25017-00	CIRCLIP	1	
28	J38-46351-00-00	SHAFT, COUNTER	1	
29	J38-46361-01-00	GEAR, COUNTER 1	1	

CONTINUED ON NEXT FRAME ➤

TRANSMISSION

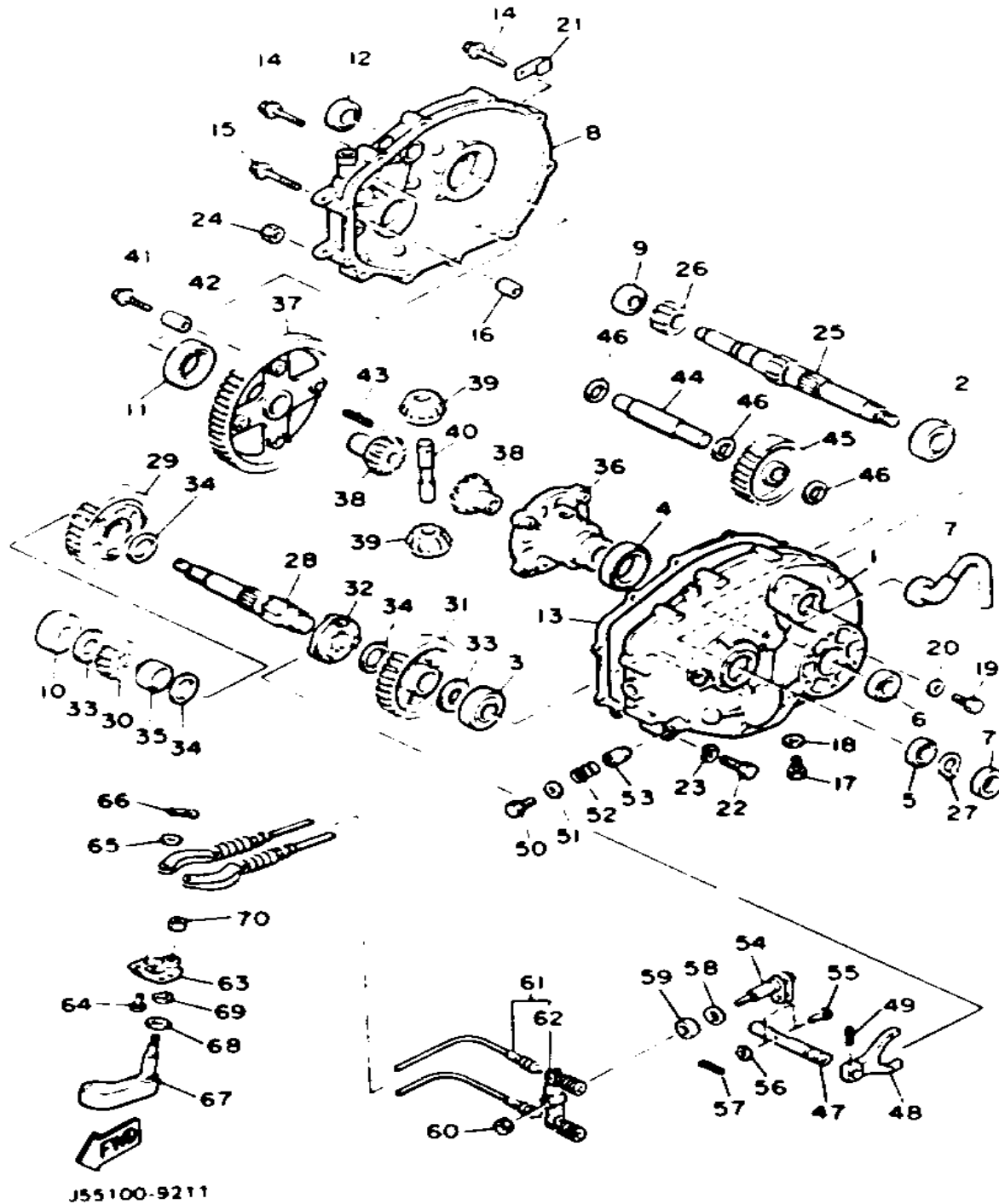

Ref. No.	Part Number	Description	Qty	Remarks
30	J38-46362-00-00	GEAR, COUNTER 2	1	
31	J38-46363-00-00	GEAR, REVERSE	1	
32	J38-4636A-00-00	DOG, CLUTCH	1	
33	90201-204K8-00	WASHER, PLATE	2	
34	90201-257J2-00	WASHER, PLATE	3	
35	90387-252M8-00	COLLAR	1	
36	J38-46411-01-00	CASE, DIFFERENTIAL	1	
37	J38-46421-01-00	GEAR, RING	1	
38	J38-46414-00-00	GEAR, DIFFERENTIAL SIDE	2	
39	J38-46415-00-00	PINION, DIFFERENTIAL	2	
40	J38-46417-02-00	PIN, DIFFERENTIAL	1	
41	90105-08390-00	BOLT, WASHER BASED	4	
42	91812-16001-00	PIN, DOWEL	2	
43	91609-40036-00	PIN, spring)	1	
	91609-40040-00	PIN, SPRING	1	
44	J38-46348-00-00	SHAFT 2	1	
45	J38-46356-00-00	GEAR, IDLER	1	
46	90201-17713-00	WASHER, PLATE	3	
47	J38-4633A-00-00	BAR, SHIFT FORK GUIDE	1	
48	J38-46338-00-00	FORK, SHIFT	1	
49	91609-40020-00	PIN, SPRING	1	
50	90101-08344-00	BOLT	1	
51	90201-08087-00	WASHER, PLATE	1	
52	90501-10060-00	SPRING, COMPRESSION	1	
53	90249-07215-00	PIN	1	
54	J38-46384-00-00	LEVER, SHIFT 3	1	
55	91701-06022-00	PIN, CLEVIS	1	
56	92990-06200-00	WASHER, PLAIN	1	
57	91490-20020-00	PIN, COTTER (91401-20020-00)	1	

CONTINUED ON NEXT FRAME ►

TRANSMISSION

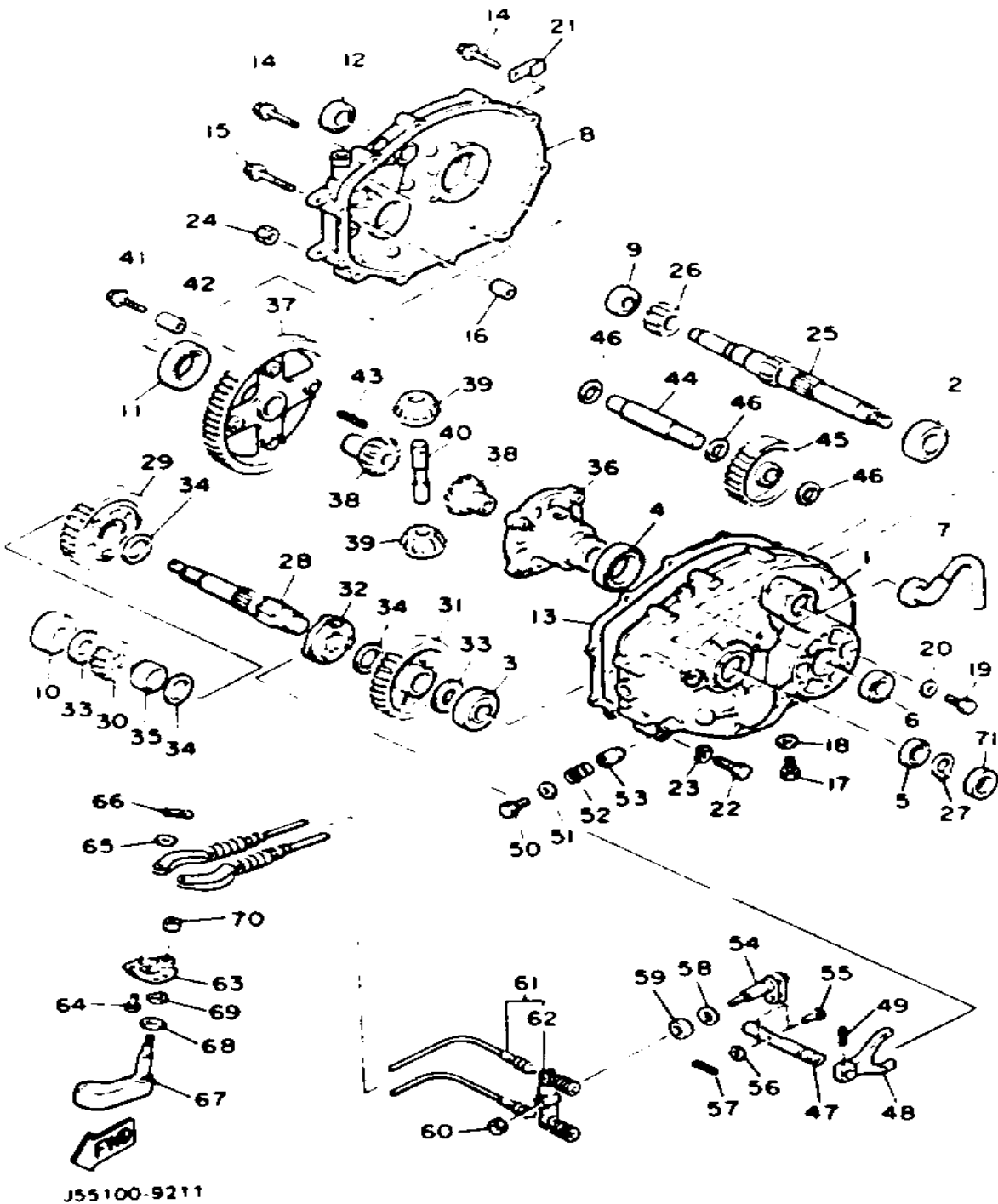

Ref. No.	Part Number	Description	Qty	Remarks
58	90201-12166-00	WASHER, PLATE	1	
59	93102-12224-00	OIL SEAL	1	
60	J55-G6383-00-00	LEVER, SHIFT	1	
61	95611-08100-00	NUT, U	1	
62	J55-G6371-00-00	SHIFT WIRE	2	
63	J38-46382-00-00	LEVER, SHIFT 1	1	
64	91702-06014-00	PIN, CLEVIS	2	
65	92990-06600-00	WASHER, PLATE	2	
66	91490-20020-00	PIN, COTTER (91401-20020-00)	2	
67	J38-46381-00-00	KNOB, SHIFT	1	
68	90201-12474-00	WASHER, PLATE	1	
	90201-12729-00	WASHER, PLATE	1	
69	99001-08600-00	CIRCLIP	1	
70	95611-08100-00	NUT, U	1	
71	J55-46322-09-00	SPACER, INPUT SHAFT	1	Alt. Part

REAR AXLE - WHEEL

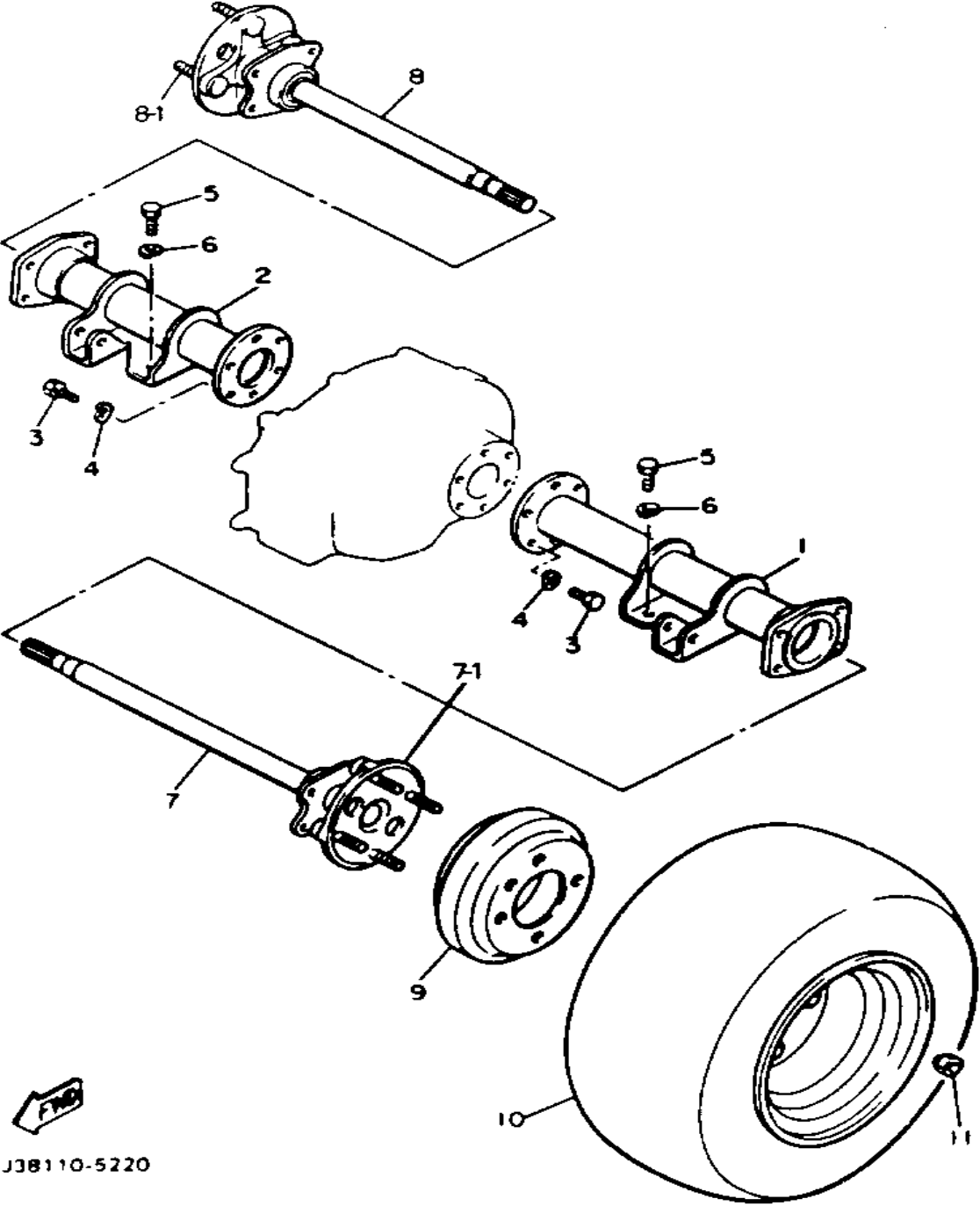

Ref. No.	Part Number	Description	Qty	Remarks
1	J38-46540-01-00	REAR AXLE HOUSING COMP.	1	
2	J38-46550-01-00	REAR AXLE HOUSING	1	
3	97013-08025-00	BOLT	12	
4	92990-08100-00	WASHER, PLAIN	12	
5	97011-10020-00	BOLT	8	
6	92990-10100-00	WASHER, SPRING	8	
7	J38-46510-00-00	REAR AXLE SHAFT COMP. ...	1	
8	J38-46520-00-00	REAR AXLE SHAFT COMP. 2 .	1	
9	J55-G6521-00-00	DRUM	2	
10	J55-F5100-00-00	FRONT WHEEL ASSEMBLY ..	2	
11	90179-12262-00	NUT	8	
7-1	90114-12004-00	. BOLT, RIBBED NECK	4	
8-1	90114-12004-00	. BOLT, RIBBED NECK	4	

J38110-5220

BUMPER

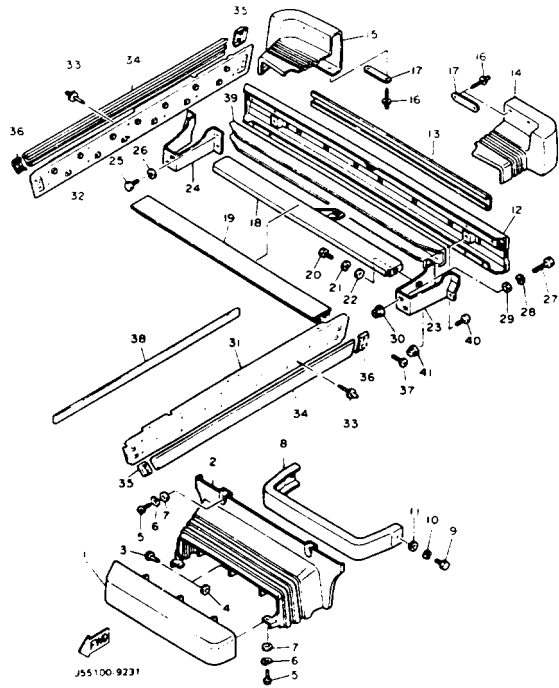

Ref. No.	Part Number	Description	Qty	Remarks
1	J55-K8162-00-00	PAD, FRONT BUMPER	1	
2	J55-K8163-00-00	COVER, BUMPER	1	
3	90269-06028-00	RIVET	3	
4	90201-076J4-00	WASHER, PLATE	3	
5	98506-05020-00	SCREW, PAN HEAD	4	
6	92906-05100-00	WASHER, SPRING	4	
7	90201-05033-00	WASHER, PLATE	4	
8	J55-K7511-00-00	BUMPER, FRONT 1	1	
9	97022-08016-00	BOLT	2	
10	92990-08100-00	WASHER, PLAIN	2	
11	92990-08600-00	WASHER, PLATE	2	
12	JG5-K8107-00-00	BUMPER SUB-ASSEMBLY, REAR	1	
13	J55-K8172-00-00	PAD, REAR BUMPER (J38-78172-00)	1	
14	J55-K8167-00-00	BUMPER, RUBBER 1	1	
15	J55-K8168-00-00	BUMPER, RUBBER 2	1	
16	90267-40077-00	RIVET, BLIND	8	
17	J17-77525-00-00	WASHER 1	4	
18	J38-78179-01-00	PLATE, EXTENSION	1	
19	J55-K8178-00-00	COVER, EXTENSION PLATE (J38-78178-00)	1	
20	97016-08016-00	BOLT	3	
21	92906-08100-00	WASHER, SPRING	3	
22	92906-08600-00	WASHER	3	
23	J55-K8174-00-00	STAY, REAR BUMPER (J38-78174-01)	1	
24	J55-K8175-00-00	STAY, REAR CUMPER 2 (J38-78175-01)	1	
25	97016-08016-00	BOLT	6	

CONTINUED ON NEXT FRAME ➤

BUMPER

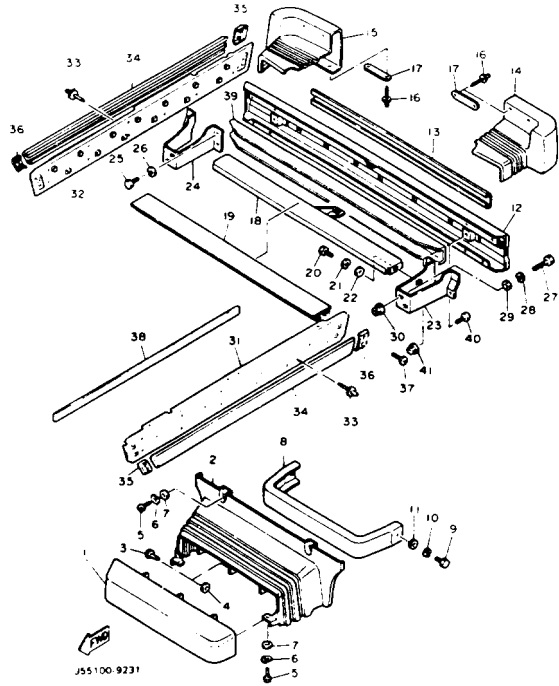

Ref. No.	Part Number	Description	Qty	Remarks
26	92906-08100-00	WASHER, SPRING	6	
27	97026-08050-00	BOLT	4	
28	92906-08100-00	WASHER, SPRING	4	
29	92906-08600-00	WASHER	4	
30	95706-08500-00	NUT, flange	4	
31	J55-WK811-00-00	PLATE, SIDE SILL KIT (L.H) (J55-K8183-00)	1	
32	J55-WK812-00-00	PLATE, SIDE SILL KIT (R.H) (J55-K8184-00)	1	
33	90267-48132-00	RIVET, blind	18	
34	J55-K818A-00-00	PROTECTOR, SIDE PLT	2	
35	J38-7818E-00-00	CAP, PROTECT.END 1	2	
36	J38-7818F-00-00	CAP, PROTECT.END 2	2	
37	98606-06014-00	SCREW, OVAL HEAD (92606-06014)	8	
38	J55-78181-00-00	PLATE 1	4	AP
39	J55-77529-00-00	SPACER, BUMPER	1	AP
40	92016-08016-00	BOLT, BUTTON HEAD	2	AP
41	95706-08500-00	NUT, flange	2	AP

BODY

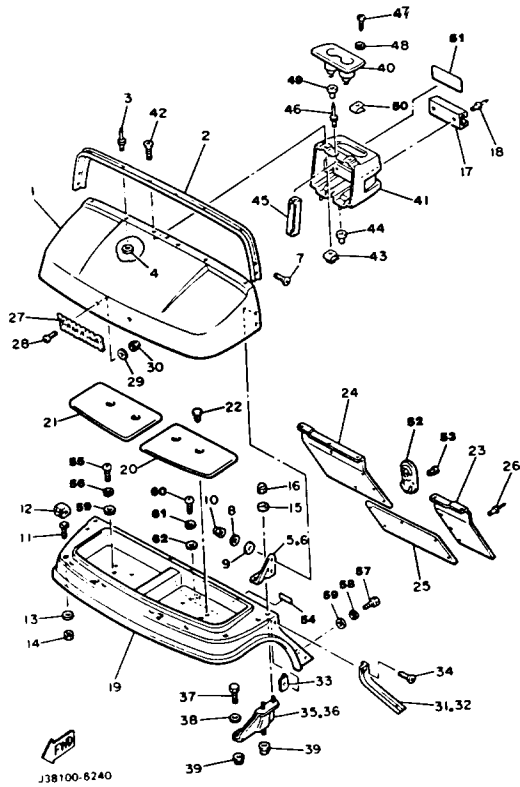

Ref. No.	Part Number	Description	Qty	Remarks
1	J55-K8116-00-00	COWL, FRONT UPPER	1	
2	J38-7811A-01-00	TRIM, UPPER COWL	1	
3	90267-48051-00	RIVET, BLIND	4	
4	90201-046J3-00	WASHER, PLATE	4	
5	J55-K811E-00-00	STAY, UPPER COWL (L.H) (J38-7811E-01)	1	
6	J55-K811F-00-00	STAY, UPPER COWL (R.H) (J38-7811F-01)	1	
7	90151-06039-00	SCREW, COUNTERSUNK	4	
8	92990-06200-00	WASHER, PLAIN	4	
	92990-06200-00	WASHER, PLAIN	6	
9	90202-06172-00	WASHER, PLATE	6	
10	95380-06800-00	NUT	4	
11	J38-7811G-00-00	BOLT, COWL FITTING	4	
12	J38-7811H-00-00	RETAINER, COWL FITTING	4	
13	90201-065F3-00	WASHER, PLATE	4	
14	95601-06100-00	NUT, U	4	
15	90201-062G3-00	WASHER, PLATE	2	
	90201-062G3-00	WASHER, PLATE	4	
16	95380-06800-00	NUT	4	
17	J55-K835A-00-00	HOLDER, BALL	1	
18	90267-63047-00	RIVET, BLIND	2	
19	J55-K8115-01-00	COWL, FRONT (J38-78115-02)	1	
20	ϕJ3-87715-10-00	PAD 1	1	
21	ϕJ3-87715-20-00	PAD 2	1	
22	ϕ90-26908-05-40	RIVET	4	
23	J55-K8231-00-00	MAT, MAIN FLOOR 1 (J38-78231-01)	1	
24	J55-K8232-00-00	MAT, MAIN FLOOR 2 (J38-78232-01)	1	

CONTINUED ON NEXT FRAME ►

BODY

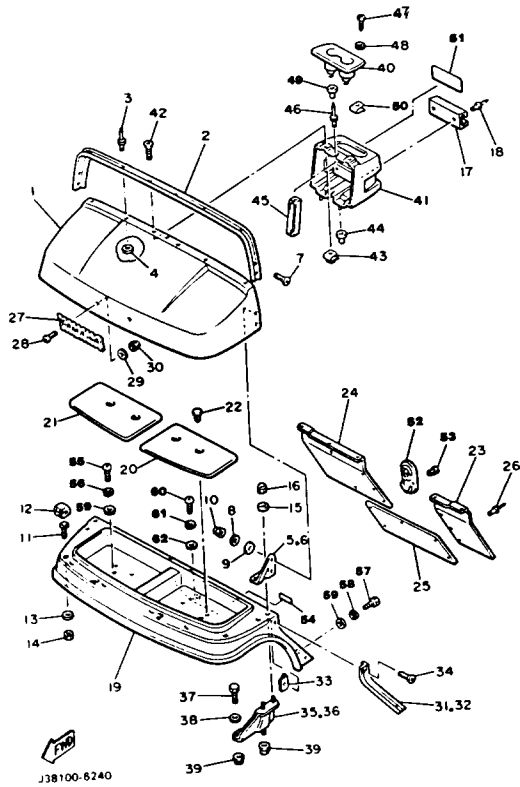

Ref. No.	Part Number	Description	Qty	Remarks
25	J55-K8236-00-00	MAT, PEDAL FLOOR (J38-78236-01)	1	
26	90267-63047-00	RIVET, BLIND	18	
27	J38-24161-00-00	EMBLEM 1	1	
28	90152-04015-00	SCREW, COUNTERSUNK	2	
29	92906-04200-00	WASHER, PLAIN	2	
30	95606-04100-00	NUT, U	2	
31	J38-7811L-00-00	TRIM, COWL SIDE (L.H)	1	
32	J38-7811M-00-00	TRIM, COWL SIDE (R.H)	1	
33	J38-7811K-00-00	NUT, TRIM FITTING	4	
34	90151-06039-00	SCREW, COUNTERSUNK	4	
35	J38-7812E-01-00	SUPPORT, UPPER COWL (L.H)	1	
36	J38-7812F-01-00	SUPPORT, UPPER COWL (R.H)	1	
37	97022-08016-00	BOLT	2	
38	92990-08600-00	WASHER, PLATE	2	
39	95701-08500-00	NUT, FLANGE (95702-08500) ..	4	
40	J55-K835E-00-00	HOLDER, BEVERAGE (J38-7835E-03)	1	
41	J55-K835G-00-00	HOUSING, HOLDER (J38-7835G-01)	1	
42	90151-06040-00	SCREW, COUNTERSUNK	2	
43	J38-78145-00-00	NUT, REAR BODY MOUNTING	2	
44	90480-12355-00	GROMMET	2	
45	J38-7834A-00-00	REINF., HOLDER	1	
46	90267-48086-00	RIVET, BLIND	2	
47	97780-50125-00	SCREW, TAPPING	2	
48	90201-05556-00	WASHER, PLATE	2	
49	90480-07241-00	GROMMET	2	
50	90183-05001-00	NUT, SPRING	2	
51	J55-77768-10-00	LABEL, WARNING (J38-77768-10)	1	U.R.

CONTINUED ON NEXT FRAME ►

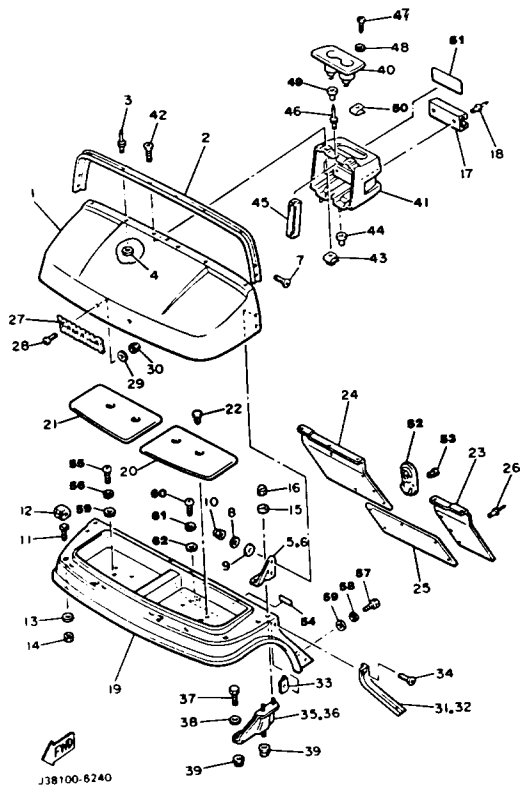

BODY

Ref. No.	Part Number	Description	Qty	Remarks
51	J55-77768-10-00	LABEL, WARNING (J38-77768-10)	2	U.R.
52	J38-78273-00-00	COVER, HOLE	1	
53	90269-11042-00	RIVET	2	
54	J38-77767-10-00	LABEL, WARNING 7	1	U.R.
55	92580-06020-00	SCREW, PAN HEAD	2	
56	92995-06100-00	WASHER, SPRING (92990-06100-00)	2	
57	97395-06020-00	BOLT, HEXAGON	2	
58	92995-06100-00	WASHER, SPRING (92990-06100-00)	2	
59	90201-06697-00	WASHER, PLATE	4	
60	92580-06020-00	SCREW, PAN HEAD	1	
61	92995-06100-00	WASHER, SPRING (92990-06100-00)	1	
62	90201-06049-00	WASHER, PLATE	1	

BODY 2

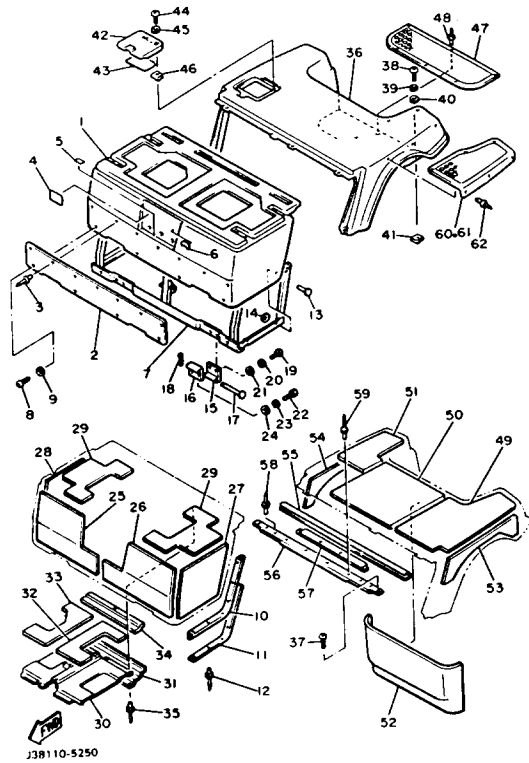

Ref. No.	Part Number	Description	Qty	Remarks
1	J55-K8141-00-00	PANEL, INTERMEDIATE BODY	1	
2	J38-7814N-00-00	PLATE, ORNAMENT	1	
3	90267-40131-00	RIVET, BLIND	7	
4	J41-77458-10-00	LABEL, WARNING (J41-77458-00-00)	1	U.R.
5	J38-77741-10-00	INDICATOR 1	1	U.R.
6	J38-77742-00-00	INDICATOR 2	1	
7	J55-K8121-00-00	REINFORCEMENT 1	1	
8	98980-06016-00	SCREW, BIND	4	
9	90201-06697-00	WASHER, PLATE	4	
10	J38-7814F-00-00	SEAL, BODY SIDE 2	2	
11	J38-7815A-00-00	PLATE, SEAL SUPPORT 1	2	
12	90267-40054-00	RIVET, BLIND	12	
13	90338-06169-00	PLUG	2	
14	90183-06011-00	NUT, SPRING	2	
15	J55-K8142-00-00	PANEL, REAR BODY	2	
16	J55-K8144-00-00	HINGE, INTERMEDIATE BODY 2	2	
17	91790-06125-00	PIN, CLEVIS	2	
18	91490-20015-00	PIN, COTTER	2	
19	97013-06012-00	BOLT (661)	4	
20	92995-06100-00	WASHER, SPRING (92990-06100-00)	4	
21	92990-06600-00	WASHER, PLATE	4	
22	97023-06020-00	BOLT (3XF) (97302-06020)	4	
23	92995-06100-00	WASHER, SPRING (92990-06100-00)	4	
24	92990-06600-00	WASHER, PLATE	4	
25	J55-K8251-00-00	PAD, SILENCER 1	1	
26	J55-K8252-00-00	PAD, SILENCER 2	1	

CONTINUED ON NEXT FRAME ►

BODY 2

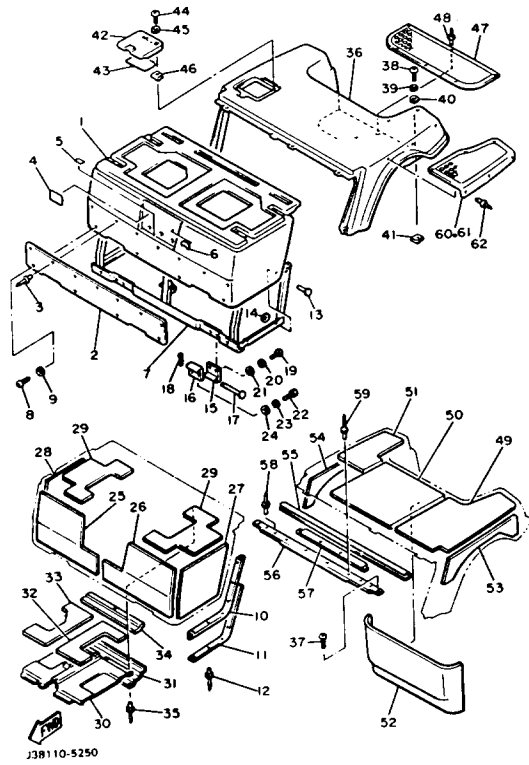

Ref. No.	Part Number	Description	Qty	Remarks
27	J55-K8253-00-00	PAD, SILENCER 3	1	
28	J55-K8254-00-00	PAD, SILENCER 4	1	
29	J55-K825K-00-00	PAD, SILENCER 6	2	
30	J55-K8261-00-00	PLATE, BODY PROTECT 1	1	
31	J55-K8262-00-00	PLATE, BODY PROTECT 2	1	
32	J55-K826A-00-00	PAD, BODY PROTECT 1	1	
33	J55-K826E-00-00	PAD, BODY PROTECT 2	1	
34	J55-K826F-00-00	PAD, BODY PROTECT 3	1	
35	90267-40054-00	RIVET, BLIND	10	
36	J55-K8142-00-00	PANEL, REAR BODY	1	
37	98501-06025-00	SCREW, panhead (92501-06025)	3	
	98902-06025-00	SCREW, BIND	3	
38	98580-06020-00	SCREW, PAN HEAD (98501-06020)	2	
39	92995-06100-00	WASHER, SPRING (92990-06100-00)	2	
40	90201-065F3-00	WASHER, PLATE	2	
41	90183-06028-00	NUT, SPRING	2	
42	J55-K8272-00-00	COVER, FUEL INLET	1	
43	J38-77764-10-00	LABEL, WARNING 4	1	U.R.
44	98511-04012-00	SCREW, PAN HEAD	2	
45	92901-04600-00	WASHER	2	
	92990-04100-00	WASHER, SPRING	2	
46	J38-78276-00-00	NUT, INLET FITTING	2	
47	J55-K8241-00-00	MAT, REAR FLOOR (J38-78241-00)	1	
48	90267-63047-00	RIVET, BLIND	6	
49	J55-K8255-00-00	PAD, SILENCER 5	1	
50	J38-78256-00-00	PAD, SILENCER 6	1	
51	J55-K8257-00-00	PAD, SILENCER 7	2	

CONTINUED ON NEXT FRAME ►

BODY 2

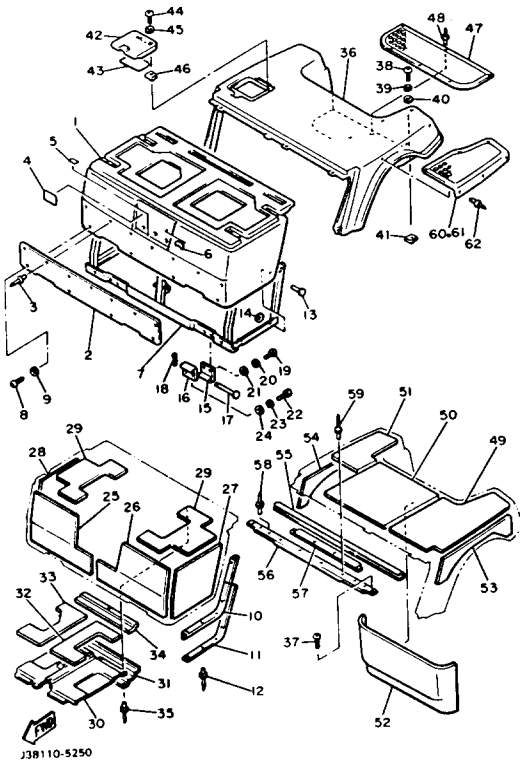

Ref. No.	Part Number	Description	Qty	Remarks
52	J55-K8258-00-00	PAD, SILENCER 8	1	
53	J55-K825L-00-00	PAD, SILENCER 17 (J38-7825L-00)	1	
54	J55-K825J-00-00	PAD, SILENCER 15 (J38-7825J-00)	1	
55	J38-7814A-00-00	SEAL, BODY UPPER	1	
56	J55-K815F-00-00	PLATE, SEAL SUPPORT 3 ...	1	
57	J38-7826G-00-00	PAD, BODY PROTECT 4	1	
58	90267-40077-00	RIVET, BLIND	4	
59	90267-40129-00	RIVET, BLIND	3	
60	J55-K8243-00-00	MAT, REAR BODY SIDE (LH) .	1	
61	J55-K8244-00-00	MAT, REAR BODY SIDE (RH) .	1	
62	90267-63047-00	RIVET, BLIND	12	

BODY FITTING

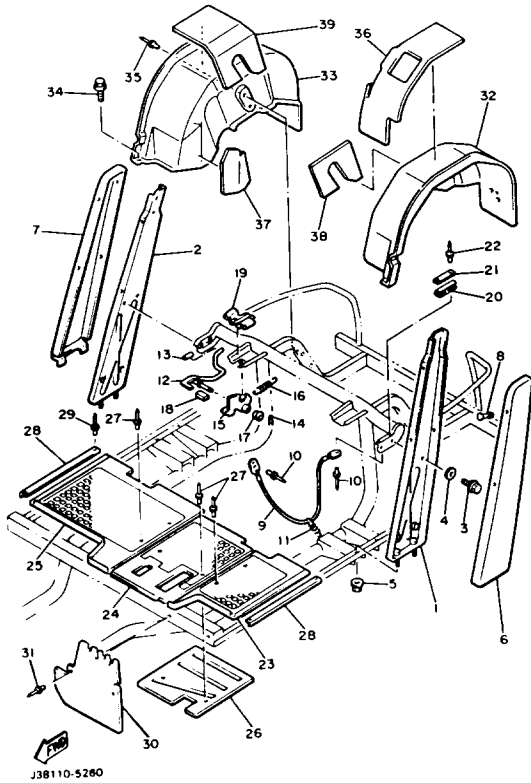

Ref. No.	Part Number	Description	Qty	Remarks
1	J55-K813A-00-00	PILLAR, SIDE (L.H) (J38-7813A-01)	1	
2	J55-K813E-00-00	PILLAR, SIDE R (J38-7813E-01)	1	
3	95811-08016-00	BOLT, FLANGE	4	
4	90201-08730-00	WASHER, PLATE	4	
5	95701-06500-00	NUT, FLANGE	4	
6	J55-K813F-00-00	COVER, SIDE PILLAR (L.H) ...	1	
7	J55-K813G-00-00	COVER, SIDE PILLAR (R.H) ...	1	
8	90267-63134-00	RIVET, BLIND	8	
9	J38-78229-00-00	WIRE, SEAT STOPPER	1	
10	90267-40087-00	RIVET, BLIND	2	
11	90507-08037-00	SPRING, TENSION	1	
12	J38-7814G-01-00	LEVER, BODY LOCK	1	
13	90445-11147-00	HOSE	1	
14	90468-18008-00	CLIP	1	
15	J38-7814H-01-00	HOOK, BODY LOCK	1	
16	90506-18374-00	SPRING, TENSION	1	
17	J38-7814L-01-00	BUSH, LEVER END	2	
18	J38-7815H-00-00	DAMPER, LOCK	1	
19	J38-78221-00-00	SHEET, BODY MOUNTING 1 ..	2	
20	J38-7814E-00-00	SEAL, BODY SIDE 1	2	
21	J38-7815E-00-00	PLATE, SEAL SUPPORT 2 ...	2	
22	90267-40054-00	RIVET, BLIND	4	
23	J55-K8233-00-00	MAT, MAIN FLOOR 3	1	
24	J55-K8234-00-00	MAT, MAIN FLOOR 4	1	
25	J55-K8235-00-00	SHEET, MAIN FLOOR	1	
26	J55-K8271-00-00	SERVICE LID, PEDAL	1	
27	90267-48101-00	RIVET, BLIND	6	
	90267-48104-00	RIVET, BLIND	6	

CONTINUED ON NEXT FRAME ►

BODY FITTING

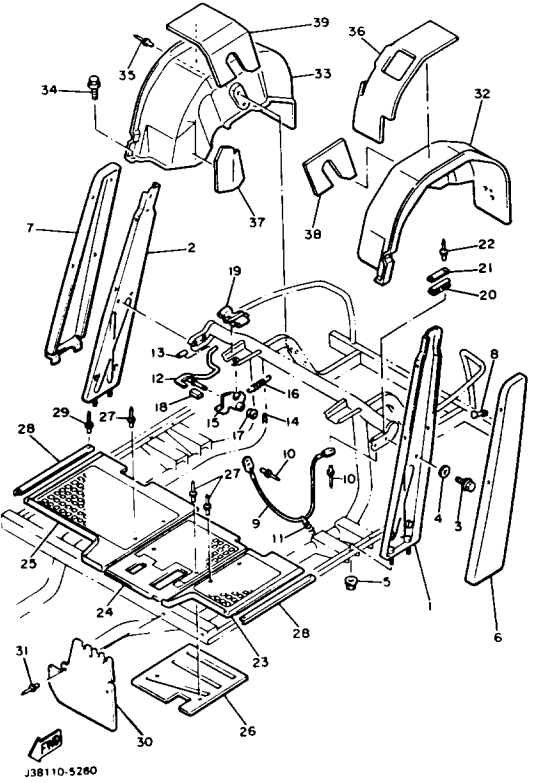

Ref. No.	Part Number	Description	Qty	Remarks
28	J38-78215-00-00	PLATE, SIDE TRIM	2	
29	90267-40054-00	RIVET, BLIND	4	
	90267-40090-00	RIVET, blind	4	
30	J55-K8187-00-00	FLAP, FRONT FENDER (J38-78187-01)	2	
31	90267-48101-00	RIVET, BLIND	4	
	90267-48104-00	RIVET, BLIND	4	
32	J55-K8191-00-00	PANEL, REAR FENDE 1	1	
33	J55-K8192-00-00	PANEL, REAR FENDER 2	1	
34	90119-06108-00	BOLT, WITH WASHER	2	
35	90267-48101-00	RIVET, BLIND	6	
	90267-48104-00	RIVET, BLIND	6	
36	J55-K8259-00-00	PAD, SILENCER 9 (J38-78259-00)	1	
37	J55-K825A-00-00	PAD, SILENCER 10 (J38-7825A-00)	1	
38	J55-K825F-00-00	PAD, silencer 12 (J38-7825F-00)	1	
39	J55-K825G-00-00	PAD, SILENCER 13 (J38-7825G-00)	1	

CARRIER

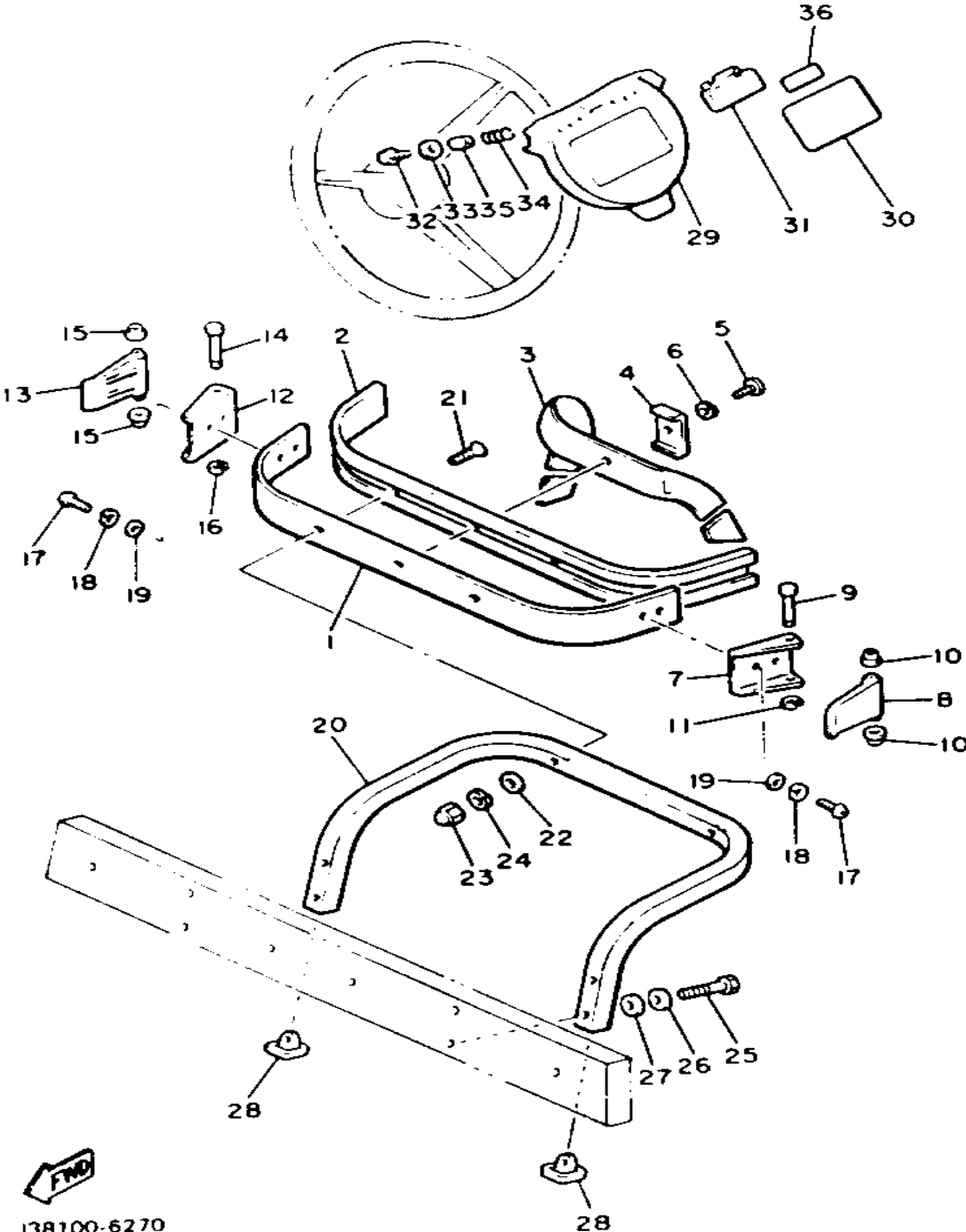

J38100-6270

Ref. No.	Part Number	Description	Qty	Remarks
1	J55-K8351-00-00	SUPPORT, BAG UPPER (J38-78351-00)	1	
2	J38-78356-00-00	PAD, BAG SUPPORT	1	
3	J38-78355-00-00	BAND	1	
4	J38-78367-00-00	PLATE, ANCHOR	1	
5	98980-06016-00	SCREW, BIND	1	
6	92995-06100-00	WASHER, SPRING (92990-06100-00)	1	
7	J17-78157-01-00	BASE, LOCK	1	
8	J17-78368-01-00	LEVER, LOCK	1	
9	J17-78369-00-00	PIN, LEVER	1	
10	90386-06108-00	BUSH	2	
11	99080-05600-00	CIRCLIP (93430-05027-00)	1	
12	J17-78157-01-00	BASE, LOCK	1	
13	J17-78368-01-00	LEVER, LOCK	1	
14	J17-78369-00-00	PIN, LEVER	1	
15	90386-06108-00	BUSH	2	
16	99080-05600-00	CIRCLIP (93430-05027-00)	1	
17	98580-06010-00	SCREW, PAN HEAD	4	
18	92995-06100-00	WASHER, SPRING (92990-06100-00)	4	
19	92990-06200-00	WASHER, PLAIN	4	
20	J55-K8352-00-00	SUPPORT, BAG LOWER 1 (J38-78352-01)	1	
21	98701-08040-00	SCREW, FLAT HEAD (92701-08040)	2	
22	90202-08022-00	WASHER, PLATE	2	
23	95380-08800-00	NUT, CROWN	2	
24	92990-08100-00	WASHER, PLAIN	2	
25	90101-08649-00	BOLT	4	

CONTINUED ON NEXT FRAME ➤

CARRIER

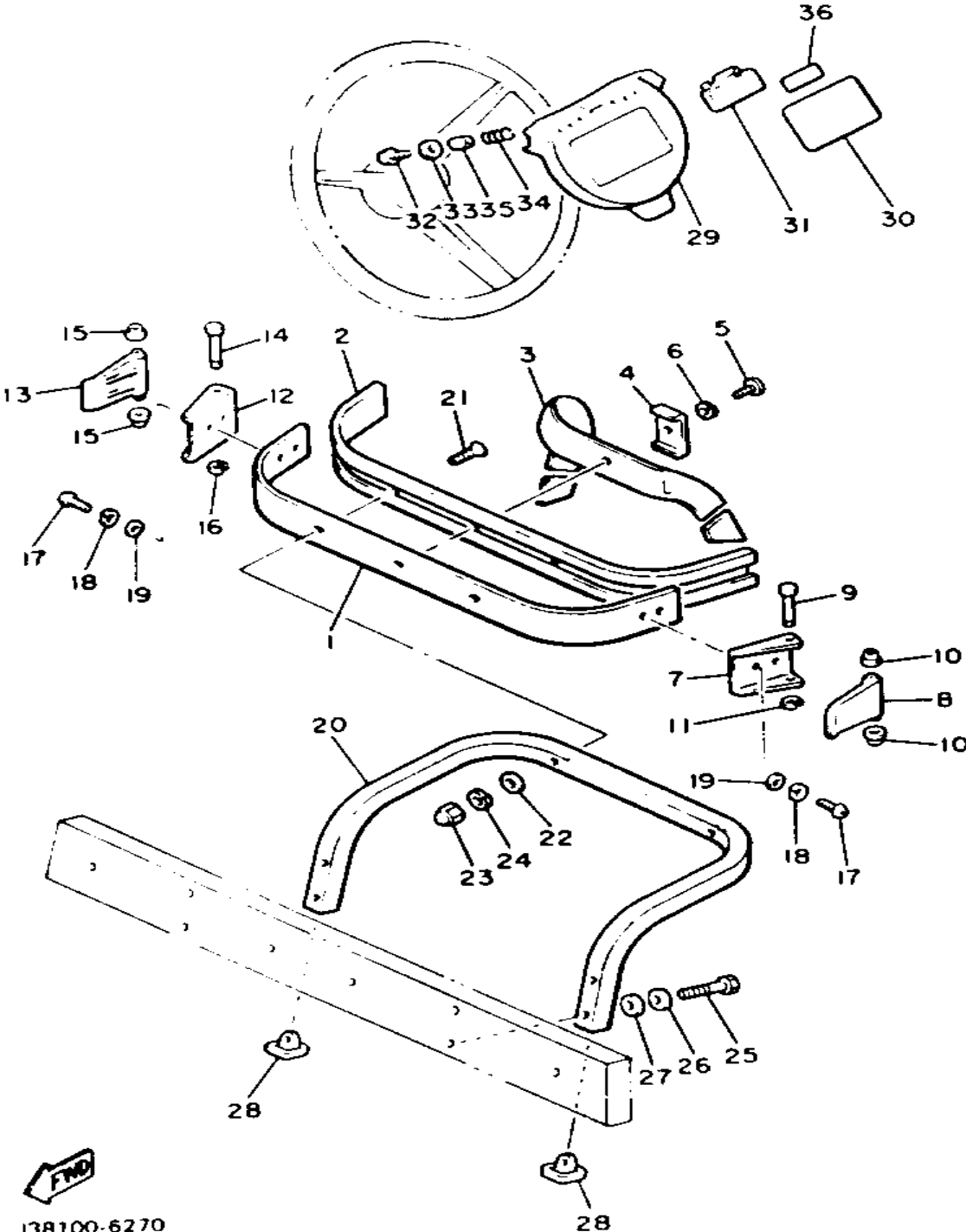

Ref. No.	Part Number	Description	Qty	Remarks
26	90202-08022-00	WASHER, PLATE	4	
27	90202-08171-00	WASHER, PLATE	4	
	90202-08171-00	WASHER, PLATE	6	
28	J38-7835H-00-00	CAP, BAG SUPPORT LOWER .	2	
29	J55-K8357-00-00	HOLDER 1	1	
30	J55-77762-10-00	LABEL, WARNING 2 (J38-77762-01)	1	
31	J55-K8358-00-00	HOLDER 2	1	
32	97706-40525-00	SCREW, TAPPING	1	
	97706-40525-00	SCREW, TAPPING	2	
33	90201-044H9-00	WASHER, PLAIN	2	
34	90502-10013-00	SPRING, CONICAL	2	
35	90387-046N7-00	COLLAR	2	
36	J38-77763-10-00	LABEL, WARNING 3	1	

SEAT

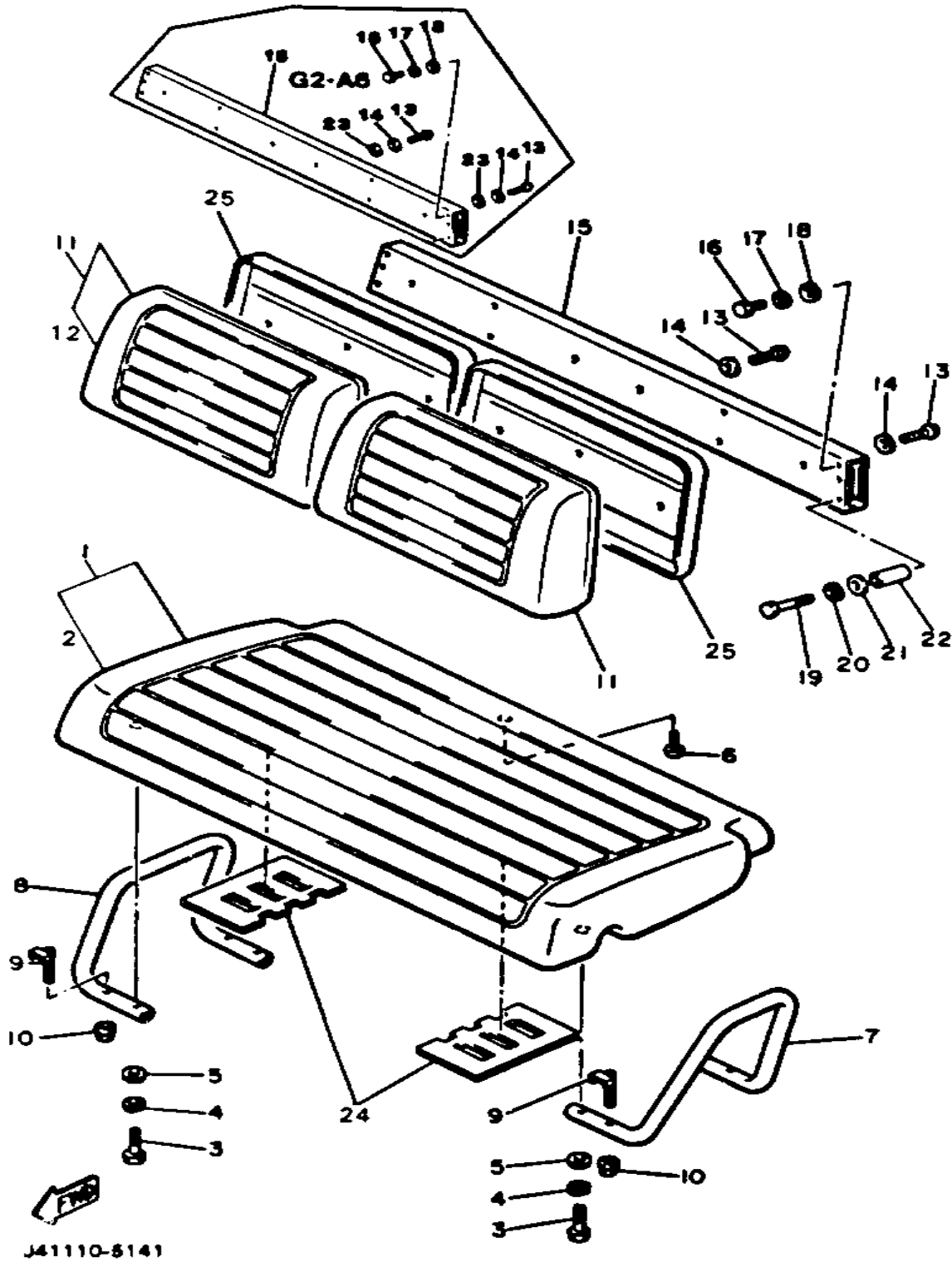

Ref. No.	Part Number	Description	Qty	Remarks
1	J55-K8401-00-00	SEAT SUB ASS'Y CUSHION (J38-78401-02)	1	
2	J55-K8404-09-00	. SEAT COVER	2	
3	97021-08065-00	BOLT	4	
4	92990-08100-00	WASHER, PLAIN	4	
5	92990-08600-00	WASHER, PLATE	4	
6	97780-50116-00	SCREW, TAPPING	1	
7	J38-78361-00-00	ARM REST 1	1	
8	J38-78362-00-00	ARM REST 2	1	
9	J38-78384-00-00	BOLT	4	
10	95601-08200-00	NUT, SELF LOCKING	4	
11	J55-K8402-00-00	SEAT SUB ASS'Y, BACK (J38-78402-01)	2	
12	J55-K841G-09-00	. COVER, SEAT BACK 2	2	
13	98980-06045-00	SCREW, BIND	4	
14	90201-065F3-00	WASHER, PLATE	4	
15	J55-K8423-09-00	SUPPORT, SEAT BACK (J55-K8423-00)	1	
16	97313-08016-00	BOLT, HEXAGON	2	
17	92990-08100-00	WASHER, PLAIN	2	
18	92990-08600-00	WASHER, PLATE	2	
19	97013-08075-00	BOLT	2	
20	92990-08100-00	WASHER, PLAIN	2	
21	92990-08600-00	WASHER, PLATE	2	
22	90387-103G9-00	COLLAR	2	
23	90202-06170-00	WASHER, PLATE	4	
24	J55-K8419-00-00	PAD, SEAT PROTECTOR	1	
25	J55-K8413-00-00	COVER, SEAT BACK	2	

J41110-5141

STARTING MOTOR

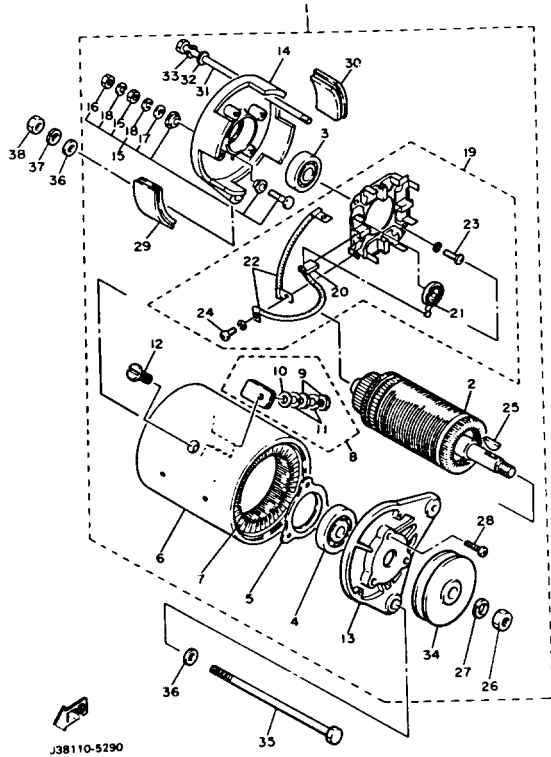

Ref. No.	Part Number	Description	Qty	Remarks
1	J38-81100-11-00	STARTER GENERATOR ASSEMBLY (JF2-H1100-00-00)	1	
2	J10-81150-10-00	. ARMATURE ASSEMBLY	1	
3	J10-81157-10-00	. BEARING 1 (6202 SD)	1	
4	J10-81158-10-00	. BEARING 2 (6203 SD)	1	
5	J10-81159-10-00	. HOLDER, BEARING	1	
6	J38-81110-10-00	. STATOR ASSEMBLY	1	
7	J38-81160-10-00	. FIELD COIL ASSEMBLY	1	
8	J10-81148-10-00	. SCREW	2	
9	95380-06600-00	.. NUT (95303-06600)	4	
10	92990-06600-00	.. WASHER, PLATE	2	
11	92995-06100-00	.. WASHER, SPRING (92990-06100-00)	4	
12	J10-81146-10-00	. SCREW	4	
13	J38-81165-10-00	. BRACKET, STARTER GENERATOR	1	
14	J10-81166-10-00	. BRACKET, STARTER GENERATOR	1	
15	J10-81147-10-00	. SCREW	2	
16	95380-06600-00	.. NUT (95303-06600)	4	
17	92995-06600-00	.. WASHER	2	
18	92990-06100-00	.. WASHER, SPRING	4	
19	JF2-81119-00-00	. BRUSH HOLDER ASSEMBLY	1	
20	JF2-81111-00-00	.. BRUSH	4	
21	J10-81113-10-00	.. SPRING, BRUSH	4	
22	J10-81115-10-00	.. WIRE, LEAD	2	
23	98580-05016-00	.. SCREW, PAN HEAD	2	
24	98580-04010-00	.. SCREW, PAN HEAD	4	
25	J38-81163-10-00	. KEY	1	
26	95301-14600-00	. NUT	1	

CONTINUED ON NEXT FRAME ►

STARTING MOTOR

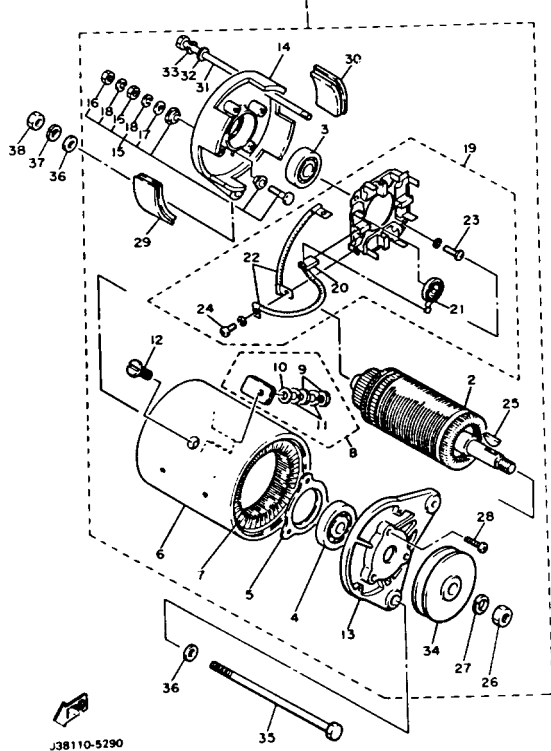

Ref. No.	Part Number	Description	Qty	Remarks
27	92901-14100-00	. WASHER, SPRING	1	
28	98501-05018-00	. SCREW, PAN HEAD	3	
29	J10-81129-10-00	. COVER, BRUSH	3	
30	J10-81129-10-00	. COVER, BRUSH	1	
31	J10-81145-10-00	. SCREW	2	
32	92990-06600-00	. WASHER, PLATE	2	
33	92995-06100-00	. WASHER, SPRING (92990-06100-00)	2	
34	J38-81161-10-00	. PULLEY	1	
35	90101-12545-00	BOLT	1	
36	92990-12600-00	WASHER, PLATE (92902-12600)	2	
37	92901-12100-00	WASHER, SPRING	1	
38	95303-12600-00	NUT	1	

ELECTRICAL 1 (G2 - A5)

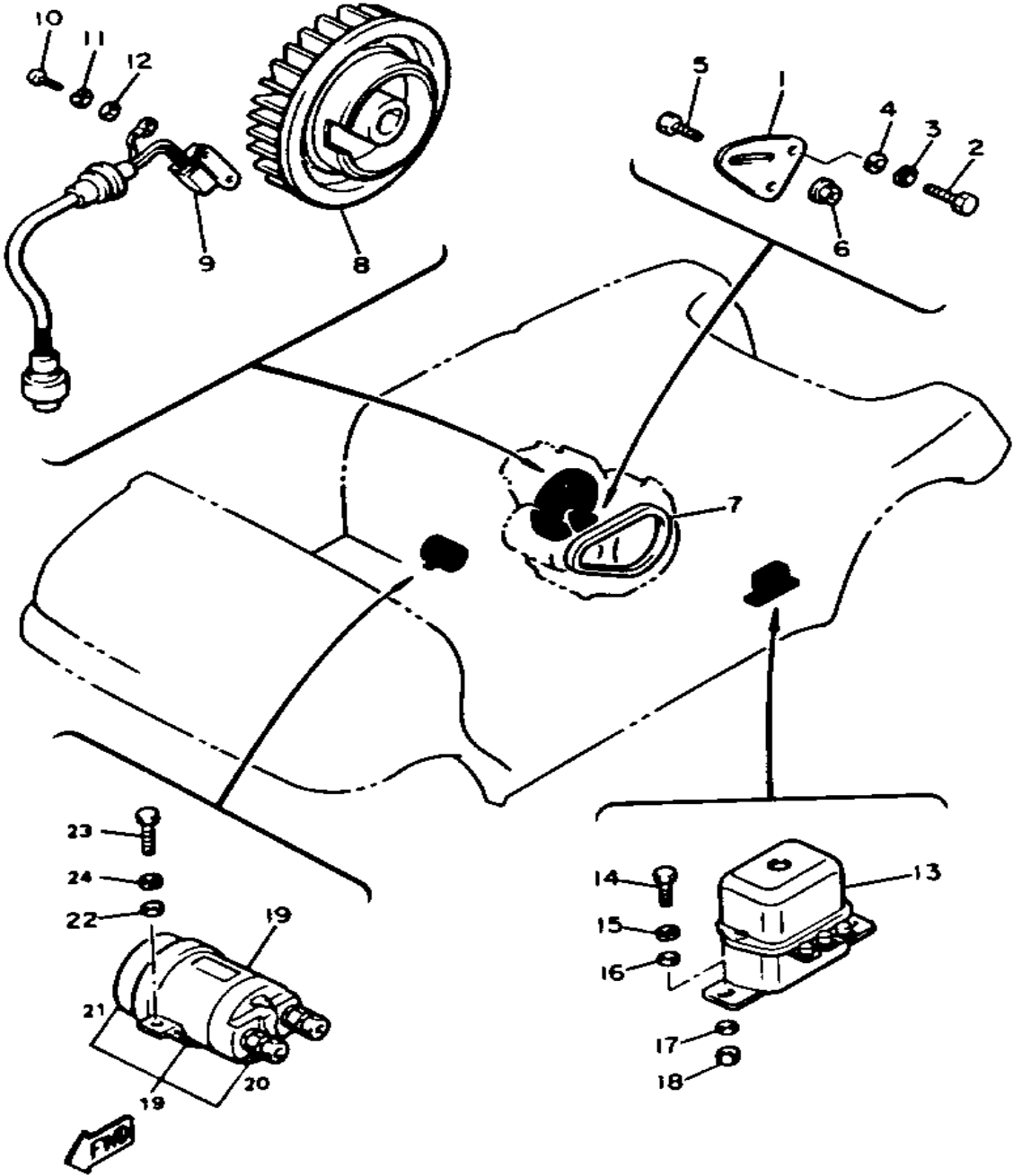

Ref. No.	Part Number	Description	Qty	Remarks
1	J38-81170-00-00	TENSIONER ASSEMBLY	1	
2	97001-08025-00	BOLT (1NV)	2	
3	92990-08100-00	WASHER, PLAIN	2	
4	92990-08600-00	WASHER, PLATE	2	
5	90109-087A5-00	BOLT	1	
6	95701-08500-00	NUT, FLANGE (95702-08500)	1	
7	J55-H1173-00-00	BELT	1	
8	J38-81350-20-00	ROTOR ASSEMBLY	1	
9	J38-85580-20-00	COIL, PULSER	1	
10	98580-05016-00	SCREW, PAN HEAD	2	
11	92990-05100-00	WASHER, SPRING	2	
12	92901-05600-00	WASHER, PLATE	2	
13	J10-81910-10-00	VOLTAGE REG ASSEMBLY ASSY	1	
14	97313-06016-00	BOLT, HEXAGON	2	
15	92995-06100-00	WASHER, SPRING (92990-06100-00)	2	
16	92990-06600-00	WASHER, PLATE	2	
17	90201-06043-00	WASHER, PLATE	2	
18	95380-06600-00	NUT (95303-06600)	2	
19	JH2-81950-01-00	RELAY ASSEMBLY	1	
20	J41-81920-09-00	. G2A/E SLND RBLDKIT	2	
21	J38-8195R-00-00	. RUBBER BOOT	2	
22	92990-06600-00	WASHER, PLATE	2	
23	97023-06020-00	BOLT (3XF) (97302-06020)	2	
24	92995-06100-00	WASHER, SPRING (92990-06100-00)	2	

J38110-5300

ELECTRICAL 1 (G2 - A6)

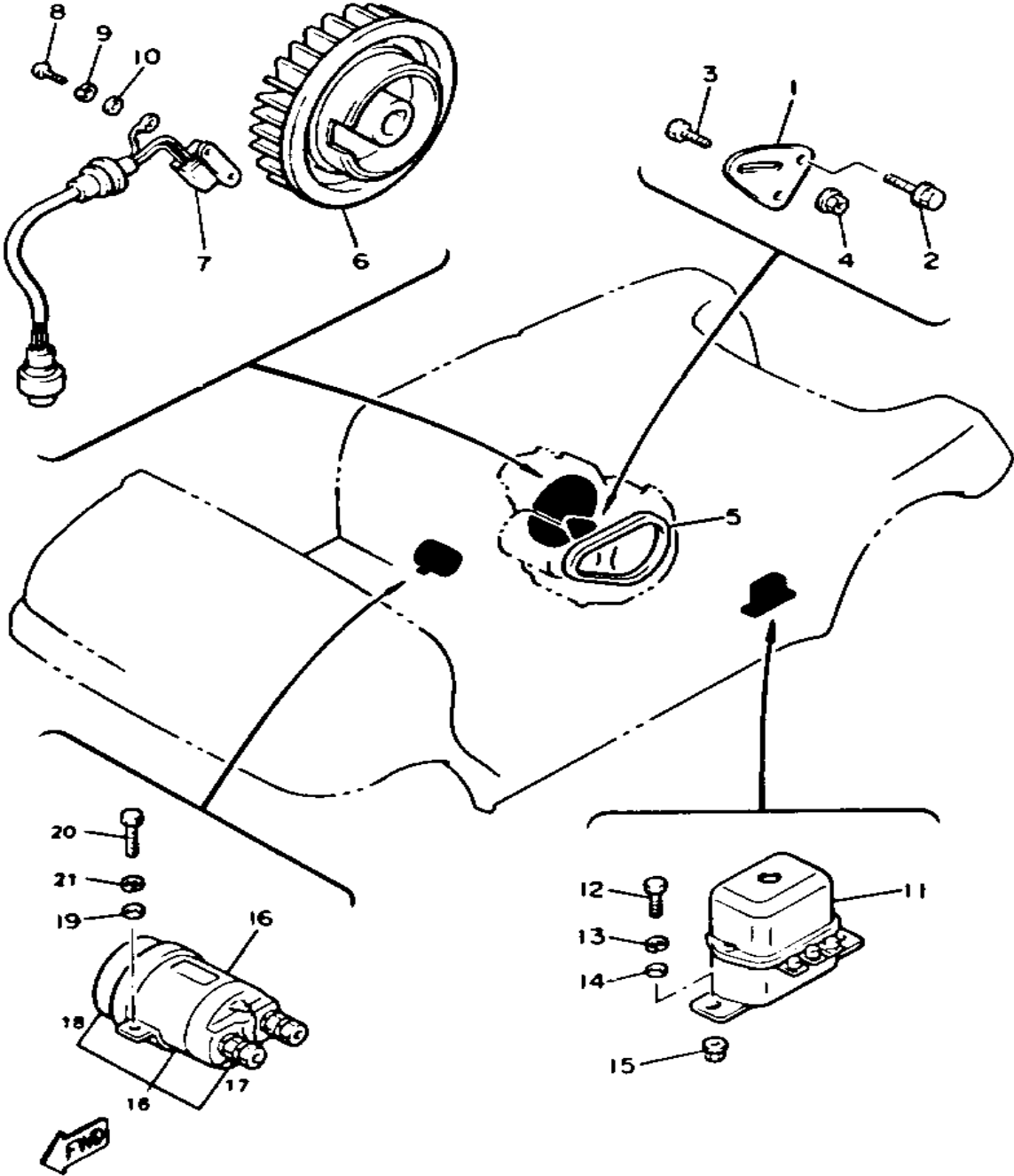

J38100-6300

Ref. No.	Part Number	Description	Qty	Remarks
1	J38-81170-00-00	TENSIONER ASSEMBLY	1	
2	95821-08025-00	BOLT, FLANGE	2	
3	90109-087A5-00	BOLT	1	
4	95701-08500-00	NUT, FLANGE (95702-08500)	1	
5	J55-H1173-00-00	BELT	1	
6	J38-81350-20-00	ROTOR ASSEMBLY	1	
7	J38-85580-20-00	COIL, PULSER	1	
8	98580-05016-00	SCREW, PAN HEAD	2	
9	92990-05100-00	WASHER, SPRING	2	
10	92901-05600-00	WASHER, PLATE	2	
11	J10-81910-10-00	VOLTAGE REG ASSEMBLY ASS'Y	1	
12	97313-06016-00	BOLT, HEXAGON	2	
13	92995-06100-00	WASHER, SPRING (92990-06100-00)	2	
14	92990-06600-00	WASHER, PLATE	2	
15	95702-06600-00	NUT, FLANGE	2	
16	J38-81950-00-00	RELAY ASS'Y	1	
17	J41-81920-09-00	G2A/E SLND RBLDKIT	2	
18	J38-8195R-00-00	RUBBER BOOT	1	
19	92990-06600-00	WASHER, PLATE	2	
20	97011-06020-00	BOLT	2	
21	92995-06100-00	WASHER, SPRING (92990-06100-00)	2	

ELECTRICAL 2

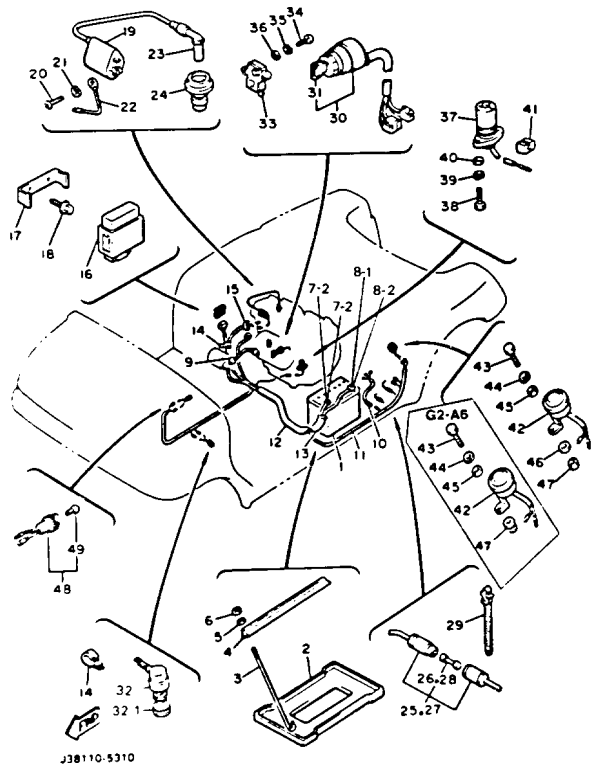

Ref. No.	Part Number	Description	Qty	Remarks
1	*---	BULB (12V-35/35W)	1	
2	J55-H2122-00-00	SEAT, BATTERY	1	
3	J17-82133-00-00	SCREW, FITTING	2	
4	J55-H2136-00-00	PLATE, BATT FITTING (J17-82136-00)	1	
5	92990-06200-00	WASHER, PLAIN	2	
6	95701-06300-00	NUT, NYLON	2	
7	J55-H2115-00-00	WIRE, PLUS LEAD (J38-82115-00)	1	
8	J55-H2116-00-00	WIRE, MINUS LEAD (J38-82116-00)	1	
9	J55-H2117-00-00	WIRE, LEAD	1	
10	J38-82105-00-00	WIRE HARNESS	1	
11	J38-82590-21-00	WIRE HARNESS ASSEMBLY (J38-82590-20)	1	
12	J55-H7196-00-00	TUBE 1 (J38-87196-00)	1	
13	J55-H7197-00-00	TUBE 2 (J38-87197-00)	1	
14	90465-06038-00	CLAMP	2	
15	90464-23041-00	CLAMP	1	
16	J38-82305-20-00	IGNITOR UNIT ASSEMBLY 1 ..	1	
17	J38-8553A-00-00	STAY UNIT	1	
18	95801-06010-00	BOLT, FLANGE	2	
19	J38-82310-20-00	IGNITION COIL ASSEMBLY ...	1	
20	98580-05020-00	SCREW, PAN HEAD	2	
21	92990-05100-00	WASHER, SPRING	2	
22	J38-82318-00-00	WIRE, SUB-LEAD	1	
23	8K1-82370-20-00	PLUG CAP ASSEMBLY	1	
24	J38-82372-00-00	SEAL, PLUG CAP	1	
25	1E6-82150-00-00	FUSE HOLDER ASSEMBLY ...	1	
26	1E6-82151-00-00	. FUSE (10 A)	2	

CONTINUED ON NEXT FRAME ►

ELECTRICAL 2

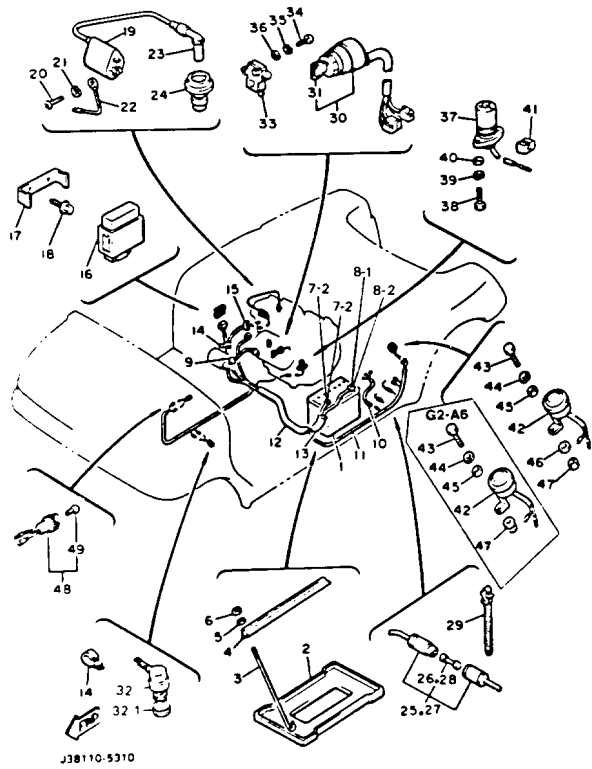

Ref. No.	Part Number	Description	Qty	Remarks
27	1E6-82150-00-00	FUSE HOLDER ASSEMBLY ...	1	
28	1E6-82151-00-00	. FUSE (10 A)	2	
29	90464-12036-00	CLAMP	2	
30	J55-82510-00-00	MAIN SWITCH ASSEMBLY ...	1	
31	J17-82511-20-00	. KEY, MAIN SWITCH	2	
32	J41-82550-00-00	STOP SWITCH ASSEMBLY ...	1	
33	J38-82617-00-00	SWITCH	1	
34	98511-04025-00	SCREW, PAN HEAD	1	
35	92901-04600-00	WASHER	1	
	92990-04100-00	WASHER, SPRING	1	
36	92901-04600-00	WASHER	1	
37	JH2-85720-00-00	OIL LEVEL GAUGE ASSEMBLY (JF2-85720-00-00)	1	
38	97023-06020-00	BOLT (3XF) (97302-06020)	2	
39	92995-06100-00	WASHER, SPRING (92990-06100-00)	2	
40	92990-06600-00	WASHER, PLATE	2	
41	J38-82598-00-00	GROMMET	1	
42	J10-83383-02-00	BUZZER	1	
43	97313-06016-00	BOLT, HEXAGON	1	
44	92995-06100-00	WASHER, SPRING (92990-06100-00)	1	
45	92990-06600-00	WASHER, PLATE	1	
46	90201-06043-00	WASHER, PLATE	1	
47	95380-06600-00	NUT (95303-06600)	1	
	95702-06600-00	NUT, FLANGE	1	
48	70R-83530-00-00	PILOT LIGHT ASSEMBLY	1	
49	123-83516-21-00	. BULB (12V-3.4W)	1	
7-1	90108-06420-00	. BOLT, BATTERY CABLE	1	
7-2	92801-06000-00	. NUT, BATTERY CABLE	1	

CONTINUED ON NEXT FRAME ►

ELECTRICAL 2

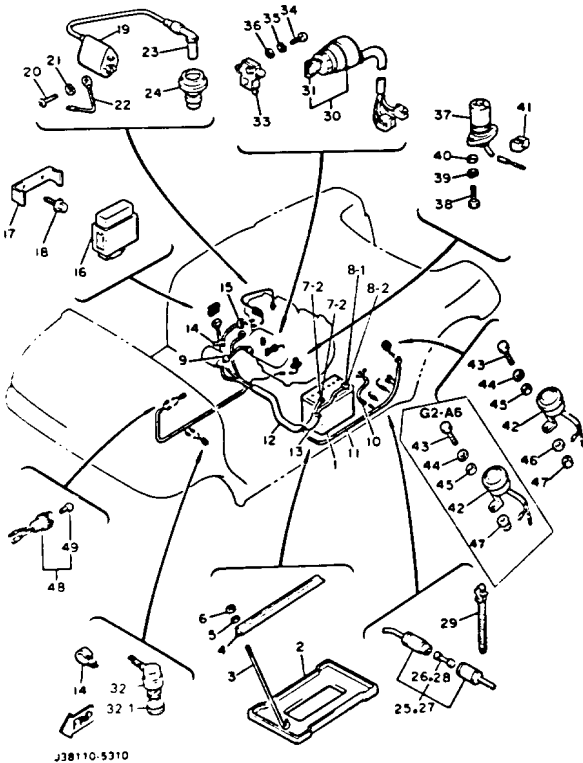

Ref. No.	Part Number	Description	Qty	Remarks
8-1	90108-06420-00	. BOLT, BATTERY CABLE	1	
8-2	92801-06000-00	. NUT, BATTERY CABLE	1	
32-1	JF2-82532-00-00	. CAP, RUBBER	1	

LIGHTING KIT

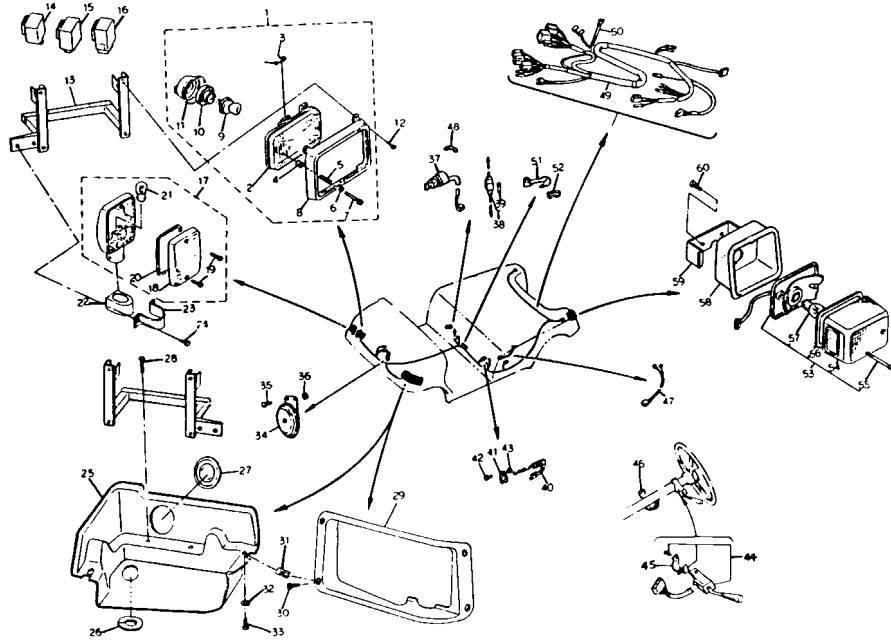

Ref. No.	Part Number	Description	Qty	Remarks
1	ϕXK-08431-00-00	. HEAD LIGHT UNIT ASS'Y ...	2	N/A
2	42U-84321-60-00	. LENS ASSEMBLY	1	
3	14T-84124-00-00	. SET SPRING (5G2-84324-A0) .	1	
4	198-84334-60-00	. NUT, ADJUSTING	2	
5	341-84332-60-00	. SPRING, SCREW	2	
6	233-84127-60-00	. WASHER, SPECIAL	2	
7	43F-84131-00-00	. SCREW, RIM ADJUSTER	2	
8	ϕXK-08431-50-00	. RIM, headlight	1	
9	1U4-84314-40-XX	. BULB, HEAD LIGHT (12V-45/40W)	1	
10	341-84393-40-00	. HOLDER, BULB	1	
11	46X-84396-00-00	. COVER	1	
12	ϕ97-60205-11-20	. SCREW, panhead w/w	8	
13	ϕXK-09713-10-00	. BRACKET, headlight (Left) ..	1	
	ϕXK-09713-20-00	. BRACKET, headlight (Right) .	1	
14	33M-83350-20-00	. FLASHER RELAY ASS'Y ...	1	
15	J42-83350-00-00	. FLASHER RELAY ASS'Y ...	2	
16	J42-85590-01-00	. CONTROL UNIT ASSEMBLY .	1	
17	15R-83310-70-00	. FRT FLSHR LITE ASSEMBLY (10L-83330-70)	1	
18	4G0-83312-00-00	. LENS, FLASHER	1	
19	97701-40518-00	. SCREW, TAPPING	2	
20	4G0-83313-00-00	. GASKET, FLSHR LENS	1	
21	ϕ25-68331-16-00	. BULB (12V-27W)	1	
22	ϕXK-08332-10-00	. DAMPER, flasher	2	
23	ϕXK-08336-80-00	. STAY, flasher	2	
24	ϕ97-60206-11-60	. SCREW, panhead w/w	4	
25	ϕXK-09714-90-00	. HOUSING, headlight (Left) ...	1	
	ϕXK-09715-00-00	. HOUSING, headlight (Right) .	1	

CONTINUED ON NEXT FRAME ►

LIGHTING KIT

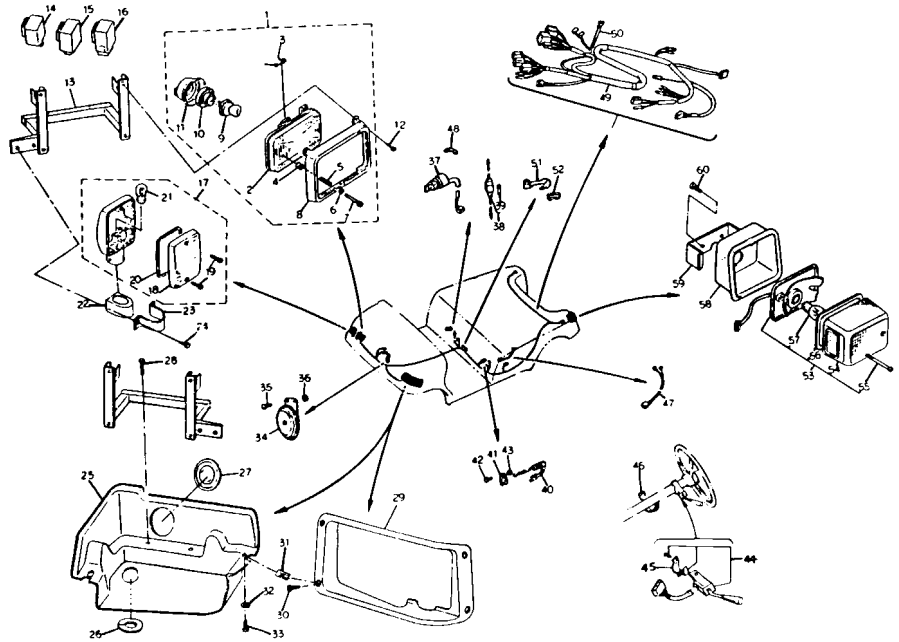

Ref. No.	Part Number	Description	Qty	Remarks
26	¢90-48024-43-90	. GROMMET	2	
27	¢XK-09714-80-00	. PLUG, headlight cover	2	
28	¢97-50206-63-50	. BOLT, hexagon head w/w ...	4	
29	¢XK-09711-50-00	. COVER, headlight (L)	1	
	¢XK-09711-60-00	. COVER, headlight (R)	1	
30	¢97-70650-31-60	. SCREW, oval head tapping ..	8	
31	90183-06035-00	. NUT, SPRING	12	
32	92990-05200-00	. WASHER, PLAIN	4	
33	97780-50120-00	. SCREW, TAPPING	4	
34	1E2-83371-21-00	. HORN	1	
35	97313-06016-00	. BOLT, HEXAGON	2	
36	¢97-50206-50-00	. NUT, flange	2	
37	¢XK-08252-00-00	. LAMP, switch ass'y	1	
38	2J2-82150-10-00	. FUSE HOLDER ASSEMBLY ..	1	
39	682-82151-00-00	. FUSE (20A)	1	
40	J13-82530-00-00	. STOP SWITCH ASS'Y	1	
	¢XK-08253-00-00	. STOP, switch ass'y	1	
41	J13-25656-00-00	. BRKT, STOP LT SWCHSTOP LIGHT SWITCH	1	
42	97313-06016-00	. BOLT, HEXAGON	1	
43	¢97-50206-50-00	. NUT, flange	1	
44	¢XK-08397-50-00	. SWITCH HANDLE	1	
45	¢XK-08395-50-00	. BRACKET 1	1	
46	25G-83936-01-00	. BAND, SWITCH CORD	2	
47	¢XK-08211-70-00	. WIRE LEAD	1	
	¢XK-08212-70-00	. WIRE LEAD 2	1	
48	J38-77742-00-00	. INDICATOR 2	1	
49	¢XK-08258-00-00	. WIRE HARNESS ASS'Y	1	
50	12R-82591-00-00	. BAND	8	

CONTINUED ON NEXT FRAME ►

LIGHTING KIT

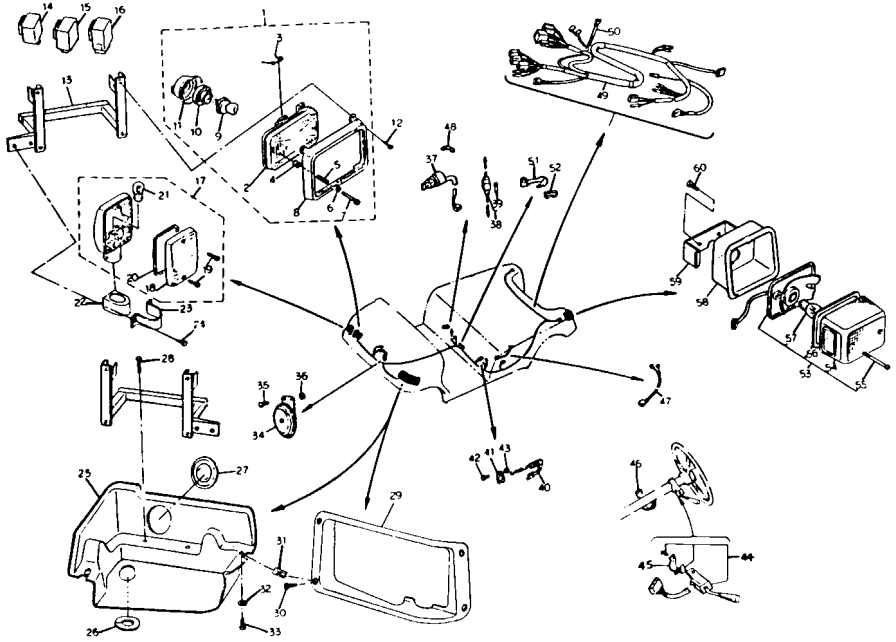

Ref. No.	Part Number	Description	Qty	Remarks
51	ϕXK-08259-40-00	. CLAMP	1	
52	ϕ1A-02588-10-10	. PROTECTOR, brake	1	
53	13W-84710-00-00	. TAILLIGHT UNIT ASS'Y	2	
54	1M8-84521-40-00	. LENS, TAILLIGHT	1	
55	1M1-84524-60-00	. SCREW, LENS FITTING	1	
56	1M1-84523-60-00	. GASKET, LENS	1	
57	256-84714-61-00	. BULB (12V-27/8W)	1	
58	ϕXK-09712-10-00	. HOUSING, taillight	2	
59	ϕXK-09711-20-00	. BRACKET, taillight	2	
60	ϕ97-50206-41-60	. BOLT, hexagon head w/washer	4	

SERVICE DATA

GOLF CAR 127 15

G2-A 1985 SERVICE DATA

MODEL - MIN L.S. NUMBER	G2-A5
Initial Engine Number / Frame Number	D38-000101 / D38-000101
Fuel type / Total Fuel Tank Capacity	Unleaded / 26 Ltr (6.8 gal)

ENGINE TYPE	4-Stroke OHV
Base / Stroke / Number Cylinders / Displacement	73mm / 48mm / 1 / 285cc
Compression Ratio / Pressure Switchin	8.11 / 12.5 kg/cm ² (177.5 psi) / 10.0 kg/cm ² (142 psi)
Piston Skirt Clearance Max / Min	0.03 ~ 0.04mm / 0.1mm
Ring End Gap Top / 2nd / 3rd	0.2 ~ 0.4mm / 0.2 ~ 0.4mm / 0.2 ~ 0.7mm
Valve Clearance (Cold) Intake / Exhaust	0.08 ~ 0.12mm / 0.08 ~ 0.12mm
Oiling System	Wet Sump
Capacity Dry	1400cc (11.5 qt)
Oil Change	1400cc (11.5 qt)
Lubricant	SAE 10W30 SL SF
Coating System	Air

DRIVE SHAFT - Manufacturer / Type / I/R Number	Mitsumi / R426-10 / D38-00
Main Jet / Pilot Jet / Pilot Screw (Turns Out)	15.5 (Dial 480) H 103 B 72.5 (Over 1000 H 67.5) 11.2
Needle Jet	14.5mm
Stop Screw Idle Speed Setting	1/4 Turn After Initial Contact

CLUTCH MECHANISM	
Type	V-Belt Automatic Centrifugal Engagement
Clutch Engagement rpm/Shift rpm	0 / 3400 rpm
Sheave Center-to-Center Distance/Offset	270.5mm / 24.8mm
V-Belt Width Station	31mm / 28mm
Primary Spring Free Length/Color	0 / 0
Secondary Spring Free Length/Color	110mm / Black

DRIVE SHAFT/CLUTCH MECHANISM DRIVE	
Lubricant/Capacity/Reduction Ratio	SAE 90 Gear Oil / 800cc (0.8 qt) / FW 13.65 RE 15.25

DRIVE SHAFT	
Type	Oil Bath Mechanical
Adjustment	Screw With Lock Nut
Factory Speed Setting	12 mph

DRIVE SHAFT	
Type	Worm and Pin
Lubricant/Capacity	Grease / 10cc (0.35 qt)
Front Axle type/tooth	Flat Engaged 0mm
Rear Axle type/tooth	Semi-floating SPT 0

SERVICE COPY	88 WEA	WCH	WCH	WCH	WCH	WCH	WCH
OWNER COPY	88 WEA	WLS	WMS	WMS	WMS	WMS	WMS

IDENTIFIER	Drum Brake on Rear
Rolling Brake Release Bolt Clearance	0.5 ~ 1.0mm
Lining Thickness Std Min	4.0mm / 2.0mm
Brake Pad Adjustment	0
Lining Adjustment (Wire Free Play)	0.1 ~ 0.5mm

WHEEL	
Type-Size	Tubeless - 4 Ply Rating / 10 x 8.5 - 8.0
Pressure	0.8 kg/cm ² (12 psi)

IGNITION SYSTEM	Transistor Controlled
Ignition Timing Static/Dynamic	0 / 25°
Spark Plug Type	NGK B-6ES
Spark Plug Gap/Torque/Cap 0	0.7 ~ 0.8mm / 2.5 m-tq (18 ft-lb) / 5K 0
Ignition Coil Test Gap/Primary/Secondary	9mm @ 300 rpm / 4.2 0 ± 15% / 13.2K 0 ± 15%
Pulse Coil or Pickup Coil Color Code / 0	White-White/Red / 550 0 ± 15% @ 20°C (68°F)
Source Coil Color Code / 0	0 / 0

STARTER/GENERATOR SYSTEM	
Type	Starter - Generator
Output of rpm	14V-15A @ 5000 rpm
Armature Connector Code / 0	A1-A2 / 0.013 0 ± 20% @ 20°C (68°F)
Battery Charging Color / 0	Red-Green / 5 0 ± 10% @ 20°C (68°F)
Starting Coil Connector Code / 0	F1-F2 / 0.008 0
Brush Length Std/Min Spring Pressure Std/Min	23mm / 16mm 2.2 lbs / 0.9 lbs
Soundend Winding 0	7 0 ± 10%

BATTERY	
Type/Capacity	Group 26 / 12V 50 AH
Specific Gravity Charge Rate	1.26 / 5% of AH Rating

0 = Does Not Apply to This Model
NA = Information Not Available
* = Available from YPO
0 = For Diagnostic Use Only

SERVICE LITERATURE		
PUBLICATION	PLATE NUMBER	REMARKS
Owner's Manual	LT-1462-04-00	
Service Manual	LT-1462-04-00	
Assembly Manual	LT-1466-04-00	

PAGE 2 OF 2

SERVICE DATA

GOLF CAR 127 15

G2-A 1985 SERVICE DATA

MODEL - MIN L.S. NUMBER	G2-A5
Initial Engine Number / Frame Number	D38-000101 / D38-000101
Fuel type / Total Fuel Tank Capacity	Unleaded / 26 Ltr (6.8 gal)

ENGINE TYPE	4-Stroke OHV
Base / Stroke / Number Cylinders / Displacement	73mm / 48mm / 1 / 285cc
Compression Ratio / Pressure Switchin	8.11 / 12.5 kg/cm ² (177.5 psi) / 10.0 kg/cm ² (142 psi)
Piston Skirt Clearance Max / Min	0.03 ~ 0.04mm / 0.1mm
Ring End Gap Top / 2nd / 3rd	0.2 ~ 0.4mm / 0.2 ~ 0.4mm / 0.2 ~ 0.7mm
Valve Clearance (Cold) Intake / Exhaust	0.08 ~ 0.12mm / 0.08 ~ 0.12mm
Oiling System	Wet Sump
Capacity Dry	1400cc (11.5 qt)
Oil Change	1400cc (11.5 qt)
Lubricant	SAE 10W30 SL SF
Coating System	Air

DRIVE SHAFT - Manufacturer / Type / I/R Number	Mitsumi / R426-10 / D38-00
Main Jet / Pilot Jet / Pilot Screw (Turns Out)	15.5 (Dial 480) H 103 B 72.5 (Over 1000 H 67.5) 11.2
Needle Jet	14.5mm
Stop Screw Idle Speed Setting	1/4 Turn After Initial Contact

CLUTCH MECHANISM	
Type	V-Belt Automatic Centrifugal Engagement
Clutch Engagement rpm/Shift rpm	0 / 3400 rpm
Sheave Center-to-Center Distance/Offset	270.5mm / 24.8mm
V-Belt Width Station	31mm / 28mm
Primary Spring Free Length/Color	0 / 0
Secondary Spring Free Length/Color	110mm / Black

DRIVE SHAFT/CLUTCH MECHANISM DRIVE	
Lubricant/Capacity/Reduction Ratio	SAE 90 Gear Oil / 800cc (0.8 qt) / FW 13.65 RE 15.25

DRIVE SHAFT	
Type	Oil Bath Mechanical
Adjustment	Screw With Lock Nut
Factory Speed Setting	12 mph

DRIVE SHAFT	
Type	Worm and Pin
Lubricant/Capacity	Grease / 10cc (0.35 qt)
Front Axle type/tooth	Flat Engaged 0mm
Rear Axle type/tooth	Semi-floating SPT 0

SERVICE COPY	88 WEA	WCH	WCH	WCH	WCH	WCH	WCH
OWNER COPY	88 WEA	WLS	WMS	WMS	WMS	WMS	WMS

IDENTIFIER	Drum Brake on Rear
Rolling Brake Release Bolt Clearance	0.5 ~ 1.0mm
Lining Thickness Std Min	4.0mm / 2.0mm
Brake Pad Adjustment	0
Lining Adjustment (Wire Free Play)	0.1 ~ 0.5mm

WHEEL	
Type-Size	Tubeless - 4 Ply Rating / 10 x 8.5 - 8.0
Pressure	0.8 kg/cm ² (12 psi)

IGNITION SYSTEM	Transistor Controlled
Ignition Timing Static/Dynamic	0 / 25°
Spark Plug Type	NGK B-6ES
Spark Plug Gap/Torque/Cap 0	0.7 ~ 0.8mm / 2.5 m-tq (18 ft-lb) / 5K 0
Ignition Coil Test Gap/Primary/Secondary	9mm @ 300 rpm / 4.2 0 ± 15% / 13.2K 0 ± 15%
Pulse Coil or Pickup Coil Color Code / 0	White-White/Red / 550 0 ± 15% @ 20°C (68°F)
Source Coil Color Code / 0	0 / 0

STARTER/GENERATOR SYSTEM	
Type	Starter - Generator
Output of rpm	14V-15A @ 5000 rpm
Armature Connector Code / 0	A1-A2 / 0.013 0 ± 20% @ 20°C (68°F)
Battery Charging Color / 0	Red-Green / 5 0 ± 10% @ 20°C (68°F)
Starting Coil Connector Code / 0	F1-F2 / 0.008 0
Brush Length Std/Min Spring Pressure Std/Min	23mm / 16mm 2.2 lbs / 0.9 lbs
Soundend Winding 0	7 0 ± 10%

BATTERY	
Type/Capacity	Group 26 / 12V 50 AH
Specific Gravity Charge Rate	1.26 / 5% of AH Rating

0 = Does Not Apply to This Model
NA = Information Not Available
* = Available from YPO
0 = For Diagnostic Use Only

SERVICE LITERATURE		
PUBLICATION	PLATE NUMBER	REMARKS
Owner's Manual	LT-1462-04-00	
Service Manual	LT-1462-04-00	
Assembly Manual	LT-1466-04-00	

PAGE 2 OF 2

TECHNICAL BULLETIN

GOLF CAR Date: 2/22/85 No. G45-002 GOLF CAR Date: 6/28/85 No. G45-006

G2-A, G2-E Crate Handling

The following information is presented in an effort to eliminate damage to the front cowl (and other golf car body parts) during shipping, handling and unloading. Taking a little time up front to properly handle the golf car crates will save a lot more time and money in the long run.

All assembly personnel should be made aware of these handling points.

AFFECTED UNITS

All G2-A
All G2-E

CRATE HANDLING HINTS

1. Do not lift the crate by the ends. The packed position of the front cowl cover allows its edge to protrude below the bottom bar on the crate. This being the case, any attempt to pick up the crate by the end will damage the cowl cover.

2. Do not push the crates at the ends. The front cowl cover is packed close to the thin bottom bar at the end of the crate. Therefore, any attempt to push the crate at that end will likely damage the cover.

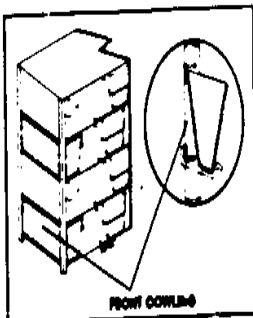

3. Use only the designed fork lift points. Only lift the crate from the sides. The proper lifting position is marked in the center by the welded-on tabs. Due to the weight and size of the crate assembly, damage may result from improper lifting.

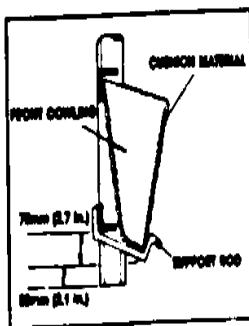
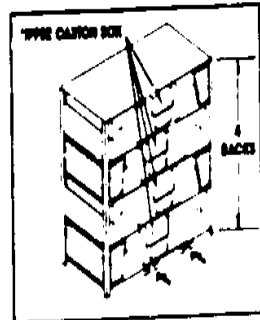

4. Lift the car from the crate carefully. The G2 is more difficult to lift from the crate because there is less clearance between the car and the crates and because the top car is higher off the ground.

If you use a fork lift to pick up the car, be extremely careful to position the forks properly to avoid damage to either the car you are lifting or the one under it.

If you use straps to pick up the car, be sure to position them so that no stress is placed on any plastic body panel components.

G2-A NEUTRAL LOCK PIN

Affected units may be towed or serviced while in neutral through the use of a pin that locks the shift lever into neutral. The pin is offered by Kent-Moore Tool Company. Use of this tool should be especially helpful during any servicing that would require engine operation while leaving the car stationary.

AFFECTED UNITS

All G2-A5 (L38)

PIN INSTALLATION PROCEDURES

2. Lift the seat cowl forward to gain access to the shift mechanism.



3. Install the lock pin through the holes in the shift arm and frame plate. Depress the button on top of the pin, then insert the pin through the holes.



WARNING

Be sure the pin goes through both the gold-colored shift-arm hole and the black frame-plate hole. This will ensure that the car is safely locked in "NEUTRAL".

WARNING

Be sure the ignition key is turned to the "OFF" position before attempting to install the neutral lock pin.

1. Place the directional shift lever in "NEUTRAL" (exactly midway between the forward and reverse shift lever detent positions).

4. Be sure the locking balls at the bottom of the pin are positioned on the other side of the frame plate, and release the button.

5. Pull the lock pin gently outward to be sure that the pin is securely locked into place. If desired, the ignition may be turned "ON" and the engine operated at this point, as the car may be safely towed.

WARNING

After servicing or towing the affected units, and before removing the neutral lock pin, be sure the ignition key is turned to the "OFF" position.

PARTS INFORMATION

Each dealership will automatically receive one neutral lock pin. The first pin will be directly billed to your parts account. To order more tools:

(It is suggested one per mechanic and one per towed car) go through Kent-Moore, (313) 774-9500.

PART NUMBER	DESCRIPTION	REMARKS	DEALER COST
YG 34972	Neutral Lock Pin	Order from Kent-Moore	

SERVICE CODE	SALES CODE	MECH	MCO	MCP	MCE	MPH

TECHNICAL BULLETIN

GOLF CAR Date: 7/2/85 No. G45-007A

G2-A; G2-E STEERING SQUEAK

Effective 10/18/85 this Technical Bulletin replaces G45-007, please remove or destroy G45-007. It denotes a change in the original Technical Bulletin.

Squeaking sounds can occur when turning the steering wheel of an affected unit. This condition is a result of the lack of grease on the rubber bushing located in the steering column. To correct this condition, follow the service procedures set forth in this bulletin.

AFFECTED UNITS

G2-A J38 000101 ~ 000431
G2-E J41 000101 ~ 003571

SERVICE PROCEDURES

1. Remove the scorecard holder.

2. Loosen the nut that holds the steering wheel to the tapered shaft inside the steering column about three turns.

WARNING

Do not remove the nut completely. The steering wheel hub hugs the tapered shaft tightly. As a result, loosening the steering wheel from the shaft will take extreme effort. Therefore, it is important for the nut to remain on the steering column, in a loosened condition, until after step 3.

3. Pop the steering wheel loose from the tapered shaft by grasping both sides of the steering wheel (near the cross bars) and rocking the wheel from side to side while pulling outward. The wheel should pop off the shaft but still be kept from coming completely off the steering column by the nut.

4. Remove the nut and steering wheel and look for the "high spots" on the rubber bushing which indicate the location of the spacing ribs on the bushing.



5. Remove the rubber bushing by tilting the pin collar and inserting a blade screwdriver between the ribs gently prying upward. Repeat this procedure on the opposite side of the bushing until it is removed.



(For additional information see reverse side)

SERVICE CODE	SALES CODE	MECH	MCO	MCP	MCE	MPH

6. Thoroughly grease the grooved area inside the bore of the bushing with molybdenum disulfide grease.



7. Reinstall the bushing into the steering column.

8. Reinstall the steering wheel onto the tapered shaft, and reinstall the nut.

NOTE: Be sure the front wheels are straight, and the cross bars of the steering wheel form a "Y" as viewed from the driver's seat. Also be sure the two drain holes in the hub are on the bottom of the hub. Then tighten the nut. Torque the nut to 8.3 m-tg (28 ft-lbs).

9. Reinstall the scorecard holder.

PARTS INFORMATION

PART NUMBER	DESCRIPTION	REMARKS	DEALER COST
J38-23814-00-00	Rubber Bushing	Replace only if damaged.	

WARRANTY

You will receive a preprinted Factory Modification Notice as shown below for each invoiced unit. The warranty labor allowance for this procedure is 0.1 hours. The Factory Modification Code is 859902. To receive credit for the labor involved in this modification, submit the completed Factory Modification Notice to the Warranty Department, make sure that the card has been signed by the dealer, and that all appropriate information has been filled in. If you do not have a Factory Modification Notice, contact the Golf Car Program Coordinator for help at (714) 764-9973.

Warranty Department, make sure that the card has been signed by the dealer, and that all appropriate information has been filled in. If you do not have a Factory Modification Notice, contact the Golf Car Program Coordinator for help at (714) 764-9973.

YAMAHA		FACTORY MODIFICATION NOTICE	
02-85: 02-85	859902	REPAIR CODE	859902
SALES CODE	00000	SALES CODE	00000
CITY AND ST.		CITY AND ST.	
G.C. Sales & Serv.		1111 Main Street, OSA 99999	
Principal Dealer		1111 Main Street, OSA 99999	
DATE OF MODIFICATION		DATE OF MODIFICATION	
DEALER SIGNATURE		DEALER SIGNATURE	

PAGE 1 OF 2

TECHNICAL BULLETIN

GOLFCAR DAY 8/2/85 No. G85-008

GOLFCAR DAY 8/23/85 No. G85-009

G2-A5

HIGH ALTITUDE CARBURETOR SPECIFICATIONS

If the affected models are to be used above 4,000 ft. use these recommended carburetor specifications for improved performance.

PROCEDURES

Adjust the carburetor according to the chart below. Refer to the service manual for specific adjustment procedures.

AFFECTED MODELS

All G2-A5 (L30)

NOTE: The pilot screw can be adjusted within 1/4 turn of the specified setting as necessary to achieve smooth low speed operation.

ALTITUDE	MAIN JET	PILOT JET	PILOT SCREW
0-4,000 ft.	#106.3	#72.5	1-1/2 Turns Out
4,000 ~ 8,000 ft.	#103.8	#72.5	1-1/2 Turns Out
8,000 ft. and above	#103.8	#67.5	1-1/2 Turns Out

NOTE: Turn the idle stop screw in 1/4 turn after touching the throttle arm.

PARTS INFORMATION

PART NUMBER	DESCRIPTION	DEALER COST
362-14238-44-00	Jet, Main #103.8	
420-14142-67-00	Jet, Pilot #67.5	
362-14238-43-00	Jet, Main #106.3	
420-14142-72-00	Jet, Pilot #72.5	

WARRANTY

Carburetor adjustments for local conditions are not covered by warranty.

SERVICE COPY	SA MGR	MECH	MECH	MECH	SALES
OFFICE COPY	GEN MGR	SALES	SALES	SALES	PAGE 1 OF 1

G2 MODELS BODY PAINTING

Some customers may want to have painted golf cars for a personalized, custom appearance. Unless the surface is correctly prepared and painted, however, the paint will not adhere to the body properly. This bulletin provides the recommended procedure for preparation and painting of G2 model polypropylene body parts.

AFFECTED UNITS

All G2 cars

PAINTING PROCEDURES

1. Degrease the parts to be painted; polypropylene naturally has an oily coating which must be removed. Wet a cloth with lacquer thinner (toluene would also be acceptable) and wipe the area three or four times. Dry the area with a clean cloth.

2. Pretreat the parts by wiping them with toluene. This chemically treats the surface to make the paint adhere better. Dry the parts again with a clean, lintless cloth.

NOTE: Toluene is not available at all paint supply outlets, and you may have to contact several places before you find it. It is more commonly found in the paint section of hardware stores than in automotive paint supply outlets.

3. Prime the parts with a primer specifically

designed for polypropylene, which should be available at auto paint supply outlets. Be sure the primer is completely dry before applying the finish coat of paint. This step is extremely important for successful painting.

4. Apply the color coat of paint. Only a high quality, acrylic-based automotive paint or urethane should be used.

NOTE: The paint should be flexible by design to avoid cracking when the parts bend during normal use. Add a flex agent to the paint, if necessary.

5. The paint should now be dried. After letting the paint dry for approximately 15 minutes, bake the painted pieces with heat lamps for 60 minutes at a temperature of 150 to 175°F (65 to 80° C).

CAUTION:

The temperature of the polypropylene material must not exceed 175°F (80°C) or the material may distort. The paint can also be dried at normal air temperature. Drying time will take one to two weeks, depending on temperature, humidity, etc. Care must be used during the drying time, because the paint will be easy to scratch or flex.

6. If a clear coat is also to be applied, follow the same procedure that was used for applying the color coat.

SERVICE COPY	SA MGR	MECH	MECH	MECH	SALES
OFFICE COPY	GEN MGR	SALES	SALES	SALES	PAGE 1 OF 1

TECHNICAL BULLETIN

GOLF CAR DAY 10/4/85 No. G85-011

G2-A SECONDARY CLUTCH SEAT SPACER

The acceleration after hill-climbing performance of the G2-A car may deteriorate, eventually to the point that the car will not move. The cause of this problem is movement of the spring seat on the secondary shaft, which can occur if the spring seat circlip slips out of its groove. The circlip groove is cut too shallow, allowing the circlip to pop out.

To prevent this problem from occurring, a specially shaped spacer should be installed on the secondary shaft. The spacer bottoms against the end of the spines and supports the spring seat in the proper position without the use of a circlip.

AFFECTED MODELS

All G2-A

SERVICE PROCEDURE

1. Follow service manual instructions to remove the secondary clutch fixed sheave, using the Kent Moore puller and holder.

PULLER: YU 90405
HOLDER: YG 40103

2. Remove the plastic spacer washer, woodruff key, sliding sheave, spring, spring seat, and circlip.

3. Install the new secondary clutch seat spacer on the secondary shaft with the beveled spined edge side towards the transmission. Install the spring. Refer to the following illustration for correct reinstallation order.

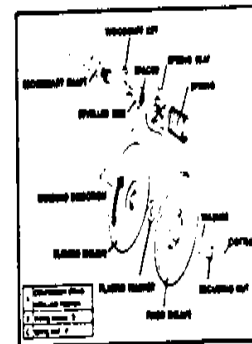

4. Grease the bushing on the secondary sliding sheave with molybdenum disulfide grease. Install the spring and the sliding sheave.

NOTE: Make sure the ends of the spring are correctly installed in the proper holes of the spring seat and sliding sheave as instructed in the service manual (see previous illustration).

5. Preload the spring by "winding" the sliding sheave about 1/3 turn in the clockwise direction before engaging the torque sensing cone. Hold the sheave in place with the holder mentioned above.

6. Clean any grease or dirt from the taper of the shaft and the fixed sheave with thinner.

7. Reinstall the plastic washer and the woodruff key then reinstall the fixed sheave.

8. Install and tighten the secondary sheave securing nut.

SECURING NUT TIGHTENING TORQUE: 6.0kg-m (43 ft-lb)

9. Install a new cotter pin.

(For additional information see reverse side)

SERVICE COPY	SA MGR	MECH	MECH	MECH	SALES
OFFICE COPY	GEN MGR	SALES	SALES	SALES	PAGE 1 OF 2

PARTS INFORMATION

PART NUMBER	DESCRIPTION	REMARKS	DEALER COST
90891-60030-00	Spacer Kit		
91401-25025-00	Cotter Pin		

WARRANTY PROCEDURE

You will receive a preprinted Factory Modification Notice as shown below for each involved unit. The warranty labor allowance for this procedure is 0.7 hour. The Factory Modification Code is 859911. To receive credit for the parts and labor involved in this modification, submit the completed Factory Modification Notice to

the Warranty Department; make sure that the card has been signed by the dealer, and that all appropriate information has been filled in. If you do not have a Factory Modification Notice, contact the Golf Car Program Coordinator for help at (714) 761-7393.

YAMAHA		FACTORY MODIFICATION NOTICE	
G2-A5	859911	859911	859911
378-30000	378-30000	378-30000	378-30000
000000	000000	000000	000000
G.C. Sales & Serv	G.C. Sales & Serv	G.C. Sales & Serv	G.C. Sales & Serv
1111 Main Street, USA 00000	1111 Main Street, USA 00000	1111 Main Street, USA 00000	1111 Main Street, USA 00000

PAGE 2 OF 2

TECHNICAL BULLETIN

GOLF CAR Date: 10/18/85 No. G85-013

G2 SEAT LATCH

Some seats on the affected units may tilt forward without releasing the latch. To correct this, the kit described below must be installed.

AFFECTED UNITS

All 1985 G2-A
All 1985 G2-E

NOTE: G2-A affected units with serial numbers lower than J38-002979, and, G2-E affected units with serial numbers lower than J41-005119 must receive the new seat latch kit; for these units begin at step 2 of the Service Procedures.

For affect units with serial numbers higher than those listed above begin at step 1 of the Service Procedures.

SERVICE PROCEDURES

1 Check the latch security by firmly grasping

the handrail on the driver's side of the car and tilt forcefully. If the seat swings forward the latch and rubber stoppers must be replaced.

NOTE: If the seat does not swing forward, the latch and stoppers are satisfactory. Do not replace them. No further work is required on the car. Do not continue with the procedures in this bulletin.

2 Remove the original rubber stoppers from the supports and discard them. Apply adhesive (3M # 776 or equivalent) to the new stoppers and install them on the metal supports.

3 Remove the old latch components and discard them. Install the new latch components.

4 Recheck the latch as in step 1.

PARTS INFORMATION

NOTE: Order parts for the program early by calling the Golf Car Coordinator at 714-761-7393.

PART NUMBER	DESCRIPTION	REMARKS	DEALER COST
90991-60026-00	Latch Kit		

WARRANTY

You will receive a preprinted Factory Modification Notice as shown below for each invoiced unit. The warranty labor allowance for this procedure is 0.1 hours. The Factory Modification Code is 809901. To receive credit for the parts and labor involved in this modification, submit the completed Factory Modification Notice to

the Warranty Department, make sure that the card has been signed by the dealer, and that all appropriate information has been filled in. If you do not have a Factory Modification Notice, contact the Golf Car Program Coordinator for help at (714) 761-7393.

SERVICE CODE	SP. MGR.	MECH.	WCH.	SVCS.	REV. 85
0000	0000	0000	0000	0000	PAGE 1 OF 1

GOLF CAR Date: 10/18/85 No. G85-014

G-2 BODY PANEL EXCHANGE

Due to breakage of the body panel material installed on the affected units, the body panels must be exchanged for panels made of an improved material.

This bulletin describes an order of procedure that will aid in efficient utilization of time and manpower during completion of the body panel exchange.

AFFECTED UNITS

All 1985 G2-A
All 1985 G2-E

SERVICE PROCEDURES

NOTE: Use of compressed air power tools will greatly decrease the time necessary to complete this procedure.

NOTE: While this job can be completed on a "one man, one car" basis, it may prove to be more efficient to have two-man teams working on each car.

1 Wash the car. Be sure to clean under the body parts as well.

2 If the car has a sun roof, remove it as an assembly and set it aside. Lifting the roof will usually require two men.

3 Remove all body panels and floor mats. Organize the removed hardware (screws, etc.) so that it will be easy to find later.

4 Remove the aluminum trim and YAMAHA name plate from the front body panels.

5 Check the serial number of the car, and compare it to those listed in other bulletins to see if it needs other work. If it does, now is the best time to complete it while the body panels are off and the car is clean.

6 Install the floor mats. Apply double-sided tape

to the rubber mat part of the inspection plate. Install the mat onto the plate. Secure the mat with the rivets supplied, being sure to install the new spacer collar through the mat first.

Install the inspection lid onto the car.

Apply double-sided tape to the underside of the other floor mats and to the floor of the car. Carefully position the floor mats and place them on the car. Secure them with the supplied rivets, being sure to install the new spacer collar through the mat first.

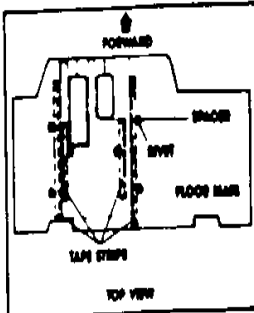

7 Install the aluminum trim and YAMAHA name plate onto the new front body panels. Be sure to install the small flat washer onto the rivet before setting it.

8 Install the new body panels and other removed parts onto the car.

NOTE: Before installing the mid body and rear body panels, loosen the three bolts holding the fuel tank in place, push down hard on the fuel cap, and retighten the bolts while still pushing down on the fuel cap. Install the new fuel cap.

Wherever there is a screw, nut, or washer that touches a painted surface, install one of the proper plastic washers between it and the painted surface.

9 If a sunroof was removed from the car, reinstall it now.

SERVICE CODE	SP. MGR.	MECH.	WCH.	SVCS.	REV. 85
0000	0000	0000	0000	0000	PAGE 1 OF 1

TECHNICAL BULLETIN

GOLF CAR Date: 10/18/85 No. G85-014

PARTS INFORMATION

Order body parts for the program ONLY by calling 714-761-7393.

The body panels are shipped in quantities of four. Minor parts (screws, rivets, etc.) are shipped in quantities of 10, per normal procedure. Other parts, such as mats, inspection covers, etc. are shipped in quantities that correspond to the total number of kits ordered.

TOOLS INFORMATION

The tools listed in this section are furnished by Yamaha Motor Corporation, USA.

- 3/8" air wrench
- 3/8" air angle drive or wrench
- 3/8" drive Phillips screwdriver
- 3/8" impact socket set
- 50 lb. air hose

NOTE: Instead of returning the entire body panels for 90 days as per normal warranty verification procedures, you should only retain clippings cut from certain areas on the panels. Diagrams of where to cut out these clippings are attached.

REAR BODY PANEL

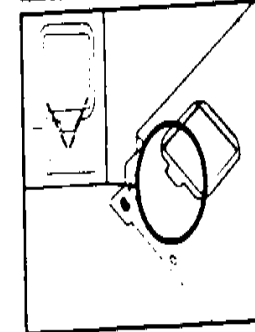

FRONT UPPER CORNER

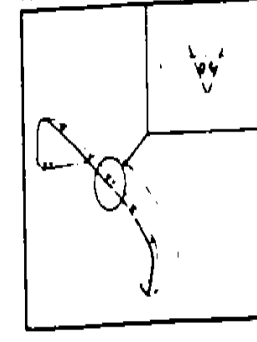

INTERMEDIATE BODY

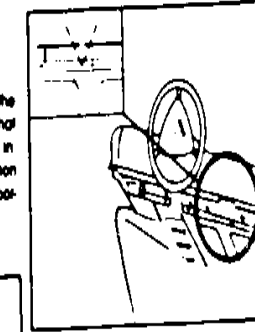

FRONT LOWER CORNER

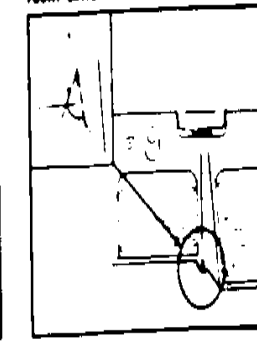

WARRANTY

You will receive a preprinted Factory Modification Notice as shown below for each invoiced unit. The warranty labor allowance for this procedure is 2.1 hours. The Factory Modification Code is 809901. To receive credit for the parts and labor involved in this modification, submit the completed Factory Modification Notice to

the Warranty Department, make sure that the card has been signed by the dealer, and that all appropriate information has been filled in. If you do not have a Factory Modification Notice, contact the Golf Car Program Coordinator for help at (714) 761-7393.

PAGE 1 OF 1

TECHNICAL BULLETIN

GOLF CAR DATE 10-18-85 BY G45-015

GOLF CAR DATE 10-18-85 BY G45-017

G2-A CHOKE CABLE HOLDER

The choke cable on affected units may slip inside the holder instead of properly applying the choke when the choke knob is pulled. The new holder will grasp the cable more tightly.

2. Install the new holder.

3. Position the choke cable so that the end of the metal cap on the outer housing is against the stopper tab.

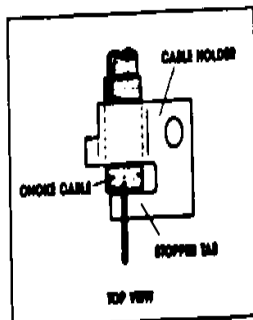
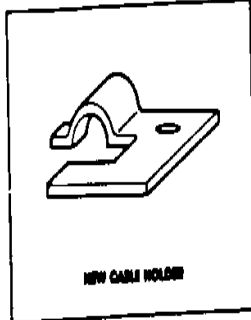

4. Tighten the lock screws.

5. Verify that choke operation is correct.

AFFECTED UNITS

All 1985 G2A

SERVICE PROCEDURES

1. Remove the old holder from the bracket and return as per standard warranty procedures.

PARTS INFORMATION

NOTE: Order parts for this program only by calling the Golf Coordinator at (714) 761-7393.

PART NUMBER	DESCRIPTION	REMARKS	DEALER COST
90891-60031-00	Holder Plate		

OFFICE CODE	SALES	MECH	MECH	MECH	PAGE 1 OF 1
OFFICE CODE	SALES	SALES	SALES	SALES	

G2 SEAT COVER INSPECTION

Some seats on affected units may develop open seams on the front corners, due to a faulty vinyl welding process. These seats are to be inspected for separation and replaced on a "case-by-case" basis.

Some seats may appear to be opening up, but in fact are only showing a characteristic of a welded vinyl seam under stress. The first section of the weld, which does not reach as high a temperature as the main weld, may open partially. However, when the spreading reaches the main portion of the weld, separation will usually stop. Seats with seams that are only partially open are not to be replaced.

PARTS INFORMATION

NOTE: Order parts for this program by calling the Golf Car Coordinator at (714) 761-7393.

PART NUMBER	DESCRIPTION	CS	DEALER COST
J36-78401-01-00	Seat Assembly		

WARRANTY

You will receive a preprinted Factory Modification Notice (as shown below) for each invoiced unit. The warranty labor allowance for this procedure is 0.5 hours. The Factory Modification Code is 859904. To receive credit for the parts and labor involved in this modification, submit the completed Factory Modification Notice to

the Warranty Department, make sure that the card has been signed by the dealer, and that all appropriate information has been filed in it. If you do not have a Factory Modification Notice, contact the Golf Car Program Coordinator for help at (714) 761-7393.

OFFICE CODE	SALES	MECH	MECH	MECH	PAGE 1 OF 1
OFFICE CODE	SALES	SALES	SALES	SALES	

TECHNICAL BULLETIN

GOLF CAR DATE 3-7-86 BY G46-005

G2-A MUFFLER BRACKET REPAIR

The exhaust tailpipe bracket on some early G2-A units may crack. This failure can usually be identified by a buzzing sound under acceleration load.

YPOI now stocks an exhaust tailpipe bracket which will allow repair of a broken bracket without replacement of the entire muffler assembly. This new tailpipe bracket should be used whenever repairing a cracked bracket. Do not perform this modification unless the bracket has cracked.

Later production units have an improved bracket installed at the factory.

AFFECTED UNITS

G2-A J36-00002 ~ 014801

SERVICE PROCEDURES

1. Remove the rear body panel. Remove the muffler assembly.
2. Using a hacksaw, cut out sections of both exhaust tailpipe brackets as shown in the photo.



3. Remove the nut on the right rear engine mount.

PARTS INFORMATION

PART NUMBER	DESCRIPTION	REMARKS	DEALER COST
90891-60033-00	Bracket Kit G-2	1 per car	

WARRANTY PROCEDURES

For each affected unit with a cracked exhaust tailpipe bracket, warranty will cover the cost of the bracket kit plus 0.5 hours labor. To receive credit, file a standard service-per-bulletin warranty request using problem code 9046.

4. Assemble the new stay on the exhaust tailpipe. Tighten the bolts only finger tight at this point to allow for adjustments during final assembly. Be sure to install the heat-proof crush damper and the rubber shift cable protector as shown.



5. Reinstall the muffler assembly, attaching the new bracket to the right rear engine mount. Route the bracket between the shift cables as shown.



6. Check for proper alignment, making sure that the the shift cables are routed so that they are not under strain or kinked. Tighten all fasteners to the correct torque specification.

EXHAUST FLANGE NUT	2.0m-kg (14 ft-lb)
EXHAUST PIPE COVER SCREW	0.7m-kg (5 ft-lb)
MUFFLER HOLDING BOLT	1.4m-kg (10 ft-lb)
ENGINE MOUNT NUT	3.5m-kg (25 ft-lb)

NOTE: This procedure should only be performed on units which have a cracked exhaust tailpipe bracket. Save all pieces of the brackets that have been cut off, and attach them to a completed Warranty Parts Tag. Hold them for 90 days from the date your request is submitted for possible recall by Yamaha.

TECHNICAL BULLETIN

TECHNICAL BULLETIN

G2-A PREVENTING AIR FILTER BOX OIL ENTRY

If engine oil level is increased above the MAX mark on the dipstick because of inaccurate readings, or if the engine is run of excessive speeds because of overriding of the mechanical governor, oil may be forced into the air filter box. It can ruin the paper filter element and cause a rich-running condition.

Customers should be cautioned that the oil level should be checked only when the car is on level ground. As seen in the illustration, with the car on as little as a 6° incline (normal road drainage pitch is about 4°), the dipstick can be easily misread.

By reducing the oil level in the engine to approximately 100 cc, this problem will no longer occur.

When adding or changing oil, the engine should be filled with 100 cc of oil. This amount lowers the oil level to a point on the dipstick between the MAX and MIN marks, about one-third the distance below the MAX mark (2mm). Do not fill above this point. This slightly reduced oil level will not affect lubrication. The oil level warning system still gives ample notice when oil must be added.

If desired, the dipstick can be remarked at the level indicated after an oil change. As usual, make sure both the dipstick and the oil-filter cap are firmly in place after any oil servicing to ensure proper circulation of oil in the cylinder head and that the governor is adjusted to factory specifications.

NOTE: This bulletin is for information only.

RELATIONSHIP BETWEEN ANGLE OF INCLINATION AND OIL LEVEL READINGS

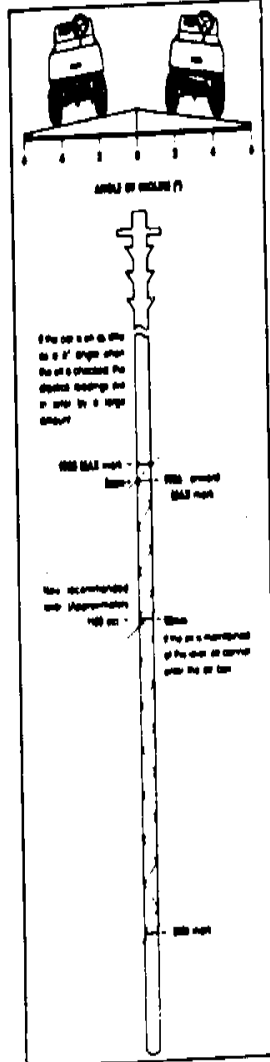

G2-AM5, A, AB BATTERY OVERCHARGING

On some of the units in the affected ranges, the voltage regulator was not set properly at the factory. An incorrectly adjusted regulator may cause overcharging of the battery, resulting in a rapid loss of battery fluid. To correct the problem, units found to have high voltage output must be correctly adjusted. Units in the affected ranges should be inspected any time rapid fluid loss is evident, or during the next routine maintenance.

If the voltage reading is within the range of 16.0 ± 0.5 volts, no adjustment is necessary. If the voltage reading is not within specification, proceed to ADJUSTMENT.

ADJUSTMENT

1. Refer to the service manual and remove the rear body panel.
2. Remove the voltage regulator cover.
3. Loosen the lock nut securing the voltage adjustment screw.
4. Turn the adjustment screw so that maximum output indicated at the battery terminals is no higher than 16.0 ± 0.5 volts.

NOTE: TO LOWER the voltage, turn the screw counterclockwise; to RAISE the voltage, turn the screw clockwise.

5. Tighten the lock nut, replace the cover and recheck for proper output.
6. Disconnect the meter, remove the neutral lock pin to reinstall the drive belt, and reassemble the unit.

WARRANTY PROCEDURE

There is no warranty allowance for inspection. The warranty labor allowance for voltage regulator adjustment is 0.3 hours. The problem code is 90N1. To receive credit, take the standard service-per-bulletin procedure.

90N1
90N1
90N1

For additional information see reverse side.

AFFECTED UNITS

G2AM5	J38-000101 ~ 005280
G2-A	J38-007101 ~ 014690
	J38-066101 ~ 070910
G2AB	J38-020101 ~ 023634

NOT AFFECTED UNITS

G2AB	J38-023635 ~ 066100
------	---------------------

*DO NOT INSPECT UNITS IN THIS SERIES

WARNING

A battery contains harmful sulphuric acid, and, while charging or overcharged, emits potentially explosive hydrogen gas. To reduce the possibility of an explosion, never service or charge a battery in a closed area, or when an open flame or sparks are present.

INSPECTION

1. Lock the car in neutral. Insert the lock pin at alternately, remove the drive belt.
2. Connect a pocket tester (D - 20-volt DC range) to the battery terminals.
3. Connect a portable tachometer (a suitable one is available from Yamaha; the part number is YU-8034) Start and rev the engine to maximum charging speed (2500 rpm or higher); maintain that speed for 15 seconds or more to ensure the charging system has stabilized, and read the output voltage on the meter.

PAGE 1 OF 2

WARRANTY PROCEDURE FOR OVERCHARGED BATTERY

In some cases, the high regulator setting has caused battery damage even with proper routine battery maintenance. Battery manufacturers expect, on average, a usable life span of three years on a battery for a gasoline-powered golf car. Yamaha will pay for the unused portion of that three year period on a battery damaged as a result of the problem described in this bulletin. The time frame is determined by the date of registration. The first year, Yamaha pays 100% of your cost for the battery. The second year rate is 67%, third year of use is 33%.

These conditions must be met to qualify for any battery coverage:

1. The car must have been sold and registered with YMAUS prior to 10/15/86 (the date technical bulletin G86-009A was released).
2. A request for the service-per-bulletin referred to in this bulletin (90N1) must be filed for the affected car.
3. A copy of the battery purchase receipt or invoice showing the battery cost must be on file with the Warranty Department. Once a receipt has been submitted, if it is not necessary to send receipt copies if additional claims are made, unless the battery cost is different. Please send these copies to your Regional Service Representative. The addresses are listed below.

Eastern Regional Service	Western Regional Service
1876 Golf Car Service	1876 Golf Car Service
Los Angeles, CA	1888 Republic Ave.
Programmer 14 8944	Orange, CA 92668

4. A separate request must be filed for each car. No blanket coverage or credits will be issued.

5. Use standard warranty procedures and problem code 83. The new DOES PLUS multiple request procedure may be used.

6. The batteries are not supplied by Yamaha. To reimburse your dealership for the battery purchase, the cost must be converted to nearest hours and tenths and inserted in the Extra Labor section (M) of the Warranty Request. Do not enter this cost as Sublet Labor. Use the formula to convert to hours:

Multiply battery cost x percent of coverage (as stated earlier), divided by your hourly labor rate. Round off the amount to the nearest 1/10 hr. Example:

\$25.00 dealer cost for battery for a G2-A sold and registered on 7/1/86, dealer labor rate \$25/hr.

\$25.00 x 67% divided by \$25/hr = .67 hr, round off to the nearest tenth of an hour = 0.7.

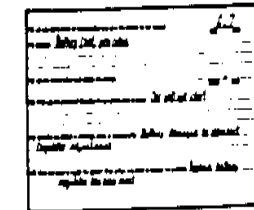

There is no labor allowance because the minimal time required to exchange the battery is adequately covered in the service-per-bulletin allowance and our prorated battery coverage.

No claims will be accepted after October 16, 1987. The time period allows one year to adjust the regulator and monitor the situation. Please remind your customers of the necessity for routine battery maintenance as stated in the Service Manual.

PAGE 2 OF 3

G2-A FUEL PUMP CLOGGING/PUMP REBUILDING

Effective 10/1/87, this technical bulletin replaces G86-014A, please remove and destroy G86-014A. Denotes a change in the original Technical Bulletin.

Some G2-A engines may experience erratic performance or stall completely due to fuel pump clogging. Water and other contaminants can leave residue and corrode the inside of the fuel pump pulse chamber stop-

ping fuel flow to the engine. If corrosion is found, the pulse chamber cover should be replaced with a new fluorine resin-coated cover (green inside coating) available from YPDI.

AFFECTED UNITS

1985 G2-AM5 J38-000101 ~ 005280	1987 G2-A J38-039010 ~ 039489
1986 G2-A J38-007101 ~ 014690	1988 G2-A J38-071101 ~ 072004
0066101 ~ 070910	
1987 G2-AB J38-020101 ~ 023634	

SERVICE PROCEDURE

WARNING

Gasoline and its vapor are highly flammable and explosive. Keep fuel away from sparks, lit cigarettes, or flame. Work in a well-ventilated area.

1. Lift the car mid-body for engine access. The fuel pump is mounted on the side of the fuel tank.
 2. Remove the crankcase pulse hose from the pump. Plug or clamp the hose from the fuel tank and carburetor to prevent fuel leakage.
 3. Remove the six Phillips screws holding the pump and pump cover together.
- NOTE: If complete rebuilding is necessary refer to page 2 of this bulletin under "ADDITIONAL PARTS INFORMATION"
4. Remove the pulse chamber cover and install the new one.
 5. Reassemble by reversing this procedure.

WARNING

Make sure the thin rubber seals, diaphragms, and gaskets are installed in the proper sequence. Improper assembly may cause diaphragm damage and fuel leakage. Proper assembly order is shown in the illustration under "ADDITIONAL PARTS INFORMATION" on page 3 of this bulletin.



PAGE 1 OF 3

SERVICE COPY	BY: WSP	CHK: WSP	CHK: WSP	CHK: WSP	CHK: WSP	PAGE 1 OF 1
OFFICE COPY	DATE: WSP	DATE: WSP	DATE: WSP	DATE: WSP	DATE: WSP	

TECHNICAL BULLETIN

GOLF CAR DATE 12-17-86 BY G86-014A

ADDITIONAL PARTS INFORMATION SERVICE PROCEDURE

A fuel pump diaphragm kit is now available from YPOI for the G2-A. It is not shown on the current nrcatcha.

Follow steps 1, 2 and 3 for the fuel pump cover installation. Refer to the exploded view and reassemble the fuel pump using the new diaphragm, gaskets, and seals included in the kit.

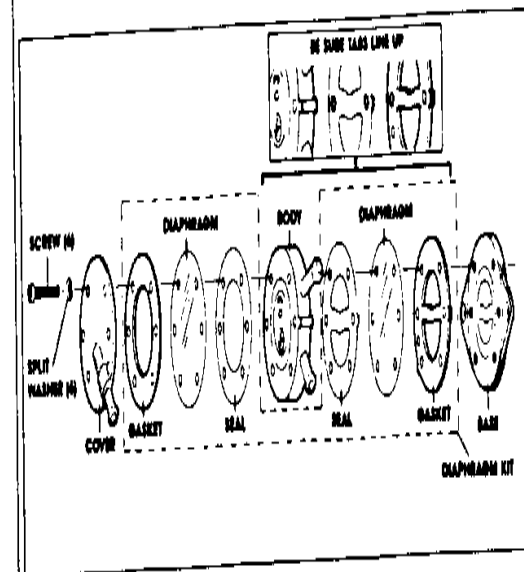

PARTS INFORMATION

PART NUMBER	DESCRIPTION	REMARKS	DEALER COST
30WH1391-01-00	Diaphragm Kit	Fuel pump rebuilding kit for G2-A	

WARRANTY PROCEDURE

Normal warranty procedures apply. That is, warranty will only pay for fuel pump rebuilding to repair a defect. The Diaphragm Kit is needed to repair a clogged fuel pump. If you have any questions, please contact your Regional Service Representative.

ROUTE TO: SERVICE PARTS WARRANTY SALES PAGE 3 OF 3

PARTS INFORMATION

PART NUMBER	DESCRIPTION	REMARKS	DEALER COST
J38-24452-19-00	Pulse Chamber Cover	Green coating inside	\$ 4.95

NOTE: The current replacement pulse chamber cover contains a gasket and one rubber seal. Inspect the seal and reuse it if it is not damaged. Future replacement pulse chamber covers will not contain this seal. See Additional Parts section on page 3 of this bulletin for Diaphragm Kit information.

WARRANTY PROCEDURE

35

The warranty labor allowance for this procedure is 0.1 hrs. The problem code is 35. List the cover part number as the primary failed part. Write "per bulletin G86-014A" in sections 11, 13, 14, and 15.

NOTE: Do not put parts or labor for fuel pump rebuilding on the Warranty Request for cover replacement.

11. List any failed parts or broken wiring and give the reason for the failure. PER BULLETIN G86-014A

12. List any repair labor and attach the receipt. PER BULLETIN G86-014A

13. Attach all the pertinent receipts for warranty repair to repair. PER BULLETIN G86-014A

14. Check for defect in material, parts or workmanship. PER BULLETIN G86-014A

15. Other way back to repair the defect? What other way back to repair the defect? PER BULLETIN G86-014A

PAGE 2 OF 3

TECHNICAL BULLETIN

GOLF CAR DATE 4-8-87 BY G87-001

G2-A WIRE HARNESS PROTECTION

INTRODUCTION

PROBLEM: Possible damage to wiring harness or starter solenoid relay.

REMEDY: Install a cable tie around the harness and frame to secure the harness and keep it from becoming fouled.

CAUSE: Vegetation, brush, or other debris may catch the wire harness near where if a starter solenoid relay is mounted.

DEALER ACTION SUMMARY

1. Obtain locally a supply of at least 8-inch-long cable ties.
2. Install a cable tie on all affected units.

1. File a service-per-bulletin (SP-BW) Warranty Request.

AFFECTED UNITS

G2-A45 1985 J38-000101 ~ 005280
 G2-A 1986 J38-007101 ~ 018590
 G2-AB 1987 J38-026101 ~ 070910
 G2-AB 1987 J38-020101 ~ 039000

SERVICE PROCEDURE

1. Open the seat cowl to gain access to the harness. Inspect the harness for any frayed or broken insulation or wires. If necessary, make appropriate repairs.
2. Position the wire harness, as shown, near the top of the frame tube, so it cannot be fouled.

NOTE: It may be necessary to loosen the nut that holds the positive (+) battery cable to the solenoid relay, rotate the L-choy, so cable terminal toward the rear to positive, the battery cable so it cannot be fouled, and retighten the nut.

(For additional information see reverse side)

PAGE 1 OF 2

SERVICE PROCEDURE (Cont'd.)

3. Securely wrap the cable tie around the frame tube, heavy starter cable, and the right-hand portion of the harness that includes the wires to the starter relay, trim the cable tie, if necessary.



Make sure the low-voltage White/Gold and Black wires that go to the terminals on the starter solenoid relay are not too tight once the cable tie is tightened. If necessary, increase slack by working the harness through the cable tie toward the relay. Also make sure the White/Gold, Green, and Black wires which are joined with snap connectors are not secured under the cable tie.

4. Close the seat cowl.

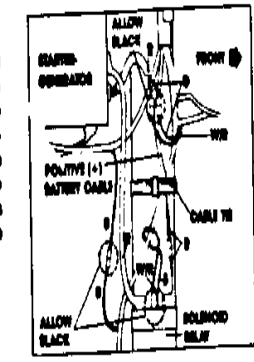

PARTS INFORMATION

Because there are numerous local sources (auto parts houses, electronics stores, hardware stores, etc.) in each dealership's area, the required cable tie (at least 8" in length) can be obtained readily and inexpensively. Each dealer will be automatically reimbursed for one cable tie with each warranty request submitted (see WARRANTY INFORMATION for details). No other parts are necessary.

WARRANTY INFORMATION

The labor allowance for this operation is 0.1 hours. The problem code is 90HW.

NOTE: A payment of 30 cents (plus 10% handling) will be automatically added to the parts category of each warranty request to cover the cost of the locally-obtained cable tie.

To receive credit, submit a standard service-per-bulletin request.

90HW

Other problem code not covered by this

PAGE 2 OF 2 ROUTE TO: SERVICE PARTS WARRANTY SALES

TECHNICAL BULLETIN

G2-A (J38) SERVICE MANUAL CORRECTION

INTRODUCTION
The CHAMPION spark plug used on pages 7-29 and 8-7 in the G2-A Service Manual is incorrect. The correct spark plug has a 3/4" thread reach and not 1/2" as listed in the manual. Performance is adversely affected by using the incorrect spark plug.

AFFECTED UNITS
All G2-A (Starting I.D. J38-000101)

DEALER ACTION SUMMARY
All service manuals should be modified to reflect the changes listed in this bulletin. Also notify all service personnel of these corrections.

HOW TO READ SPARK PLUG I.D. NUMBERS
If replacement of the spark plug is necessary, use the correct type/number/range as listed. Spark plug installation torque is 14 ft lb (2.0 Nm).

RECOMMENDED SPARK PLUG FOR		
G1-A, G3-A	NGK	CHAMPION
G2-A	BP54S	LPCM
	B5ES	NSC, NS

CORRECT FOR G2-A
NGK B5ES or CHAMPION NS, NSC

DISCONNECT FOR G2-A
CHAMPION LPCM

Second & third letter refers to construction features most often single letter is used

Letter	Thread Size	Hexagonal Size
B	14mm (0.55 in)	28.0mm (1.10 in)
D	16mm (0.63 in)	32.0mm (1.26 in)

First letter refers to thread reach

Letter	Thread Reach
H	12.7mm (1/2 in)
I	19.0mm (3/4 in)

Second letter refers to construction features, etc.

Letter	Construction Feature
A	Preformed resistor nose type
B	Resistor type

Third letter refers to copper core power electrode (steel) Center electrode of precious metal

Letter	Construction Feature, etc.
A	Copper core power electrode (steel)
V	Center electrode of precious metal

SPARK PLUG I.D. NUMBER: B 5 E S

WARRANTY
This bulletin is for informational purposes only. No special warranty procedures apply.

ROUTE TO: SERVICE PARTS WARRANTY SALES PAGE 1 OF 1

G2-A SHIFT CABLE PERIODIC LUBRICATION

INTRODUCTION
PROBLEM: Some units in the affected ranges have experienced difficult shifting after being in use for periods of a year or more.
REMEDY: To make certain this situation does not inconvenience any customer, an annual lubrication of the shift cable with Yamaha Lube-Zoil will minimize the possibility of stalling.

CAUSE: Moisture can enter the ends of the shift cables during normal use. This can form rust and corrosion and cause the inner cable to bind.

DEALER ACTION SUMMARY
Add yearly shift cable lubrication to the service schedule of all G2-A.

AFFECTED UNITS

G2-A145	1-88	J38-000101 ~ 036308
G2-A	1986	J38-007501 ~ 048690
G2-A8	1987	J38-020101 ~ 036308
		J38-066101 ~ 070910

NOTE: All 1987 G2-A8 units after ID number J38-036303 (except J38-066101-070910) are fitted with an improved shift cable that has a stainless steel inner wire. However, the yearly lubrication procedure should still be followed to preserve smooth cable operation.

SERVICE PROCEDURE
Lubricate the shift cables on all units with Lube-Zoil at least once a year, using a Yamaha Power Cable Injector tool. Follow the instructions on the tool package.
NOTE: If a cable has become loose, follow the service manual and replace it. Lubricate the new cable immediately following installation, and at least once every 12 months thereafter.

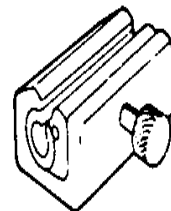

LUBE INJECTOR TOOL

PAGE 1 OF 1

TECHNICAL BULLETIN

G2-A/G2-E PRIMARY ID FRAME LOCATION CHANGE

INTRODUCTION
The placement of the stamped-in primary ID number on the vehicle frame has been changed. See the illustrations for the new locations.
NOTE: The G2-A engine number location remains the same.

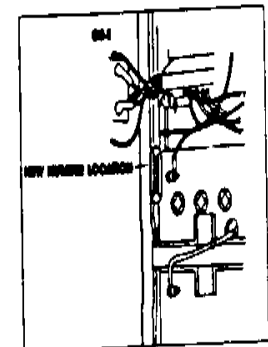
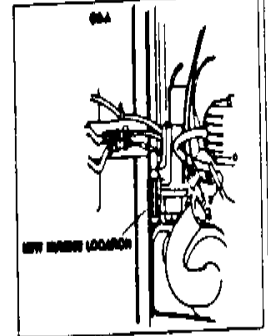

PARTS INFORMATION

PART NUMBER	DESCRIPTION	REMARKS	DEALER COST
ACC-1001-41-01	Lube-Zoil	12 cans per case	\$2.35 ea
ACC-1110-43-H	Power Cable Injector	10 per package	\$1.00 ea

The improved shift cables will be crimped in YPI block as soon as current supplies are depleted.
The part number of the improved cable remains the same. However, a white sleeve has been placed around the outer cable to identify the improved version.

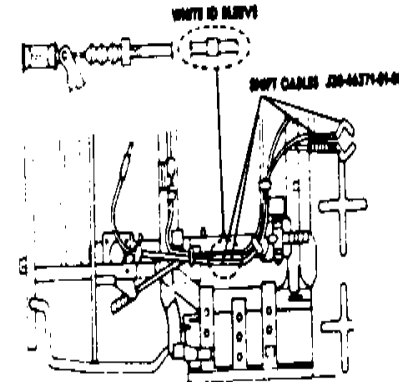

WARRANTY INFORMATION
If a unit is in warranty and a worn shift cable is replaced, follow normal warranty procedures for cable reimbursement. No warranty applies for annual lubrication, as this is a routine maintenance operation.

PAGE 2 OF 2 ROUTE TO: SERVICE PARTS WARRANTY SALES

DEALER ACTION SUMMARY
No dealer action required. This bulletin is issued only to inform you of the change in ID number location.

STAMPING ID NUMBERS
G2-A J38-072306
G2-E J41-053401

WARRANTY INFORMATION
Warranty is not affected.

ROUTE TO: SERVICE PARTS WARRANTY SALES PAGE 1 OF 1

TECHNICAL BULLETIN

G2-A STARTER BRUSH WEAR

INTRODUCTION

PROBLEM: The starter does not operate properly.

CAUSE: The starter/generator brushes have worn.

REMEDY: Install new starter/generator brushes.

NOTE: There are two types of brushes that fit the J10, and the J38.

The J10-type is harder and less conductive than the J38. These brushes will last longer, but their use may result in cold weather starting problems.

The J38-type is softer and more conductive. These brushes are required for colder weather starting.

NOTE: Always use only the J10 brushes with the G1-A.

DEALER ACTION SUMMARY

When you find a G2-A whose starter/generator brushes have worn out, use the information in this bulletin. Make sure you obtain and install the brush set that applies to the temperature range in which the car will be operated.

AFFECTED UNITS

All G2-A

Brush Set Part Number	Remarks	Dealer Cost
J10-8111-10-00	Can use in temperatures above 41°F (5°C) on G2-A for increased brush life.	
J38-8111-10-00	Good for all temperatures but wear more rapidly.	

NOTE: The J10 springs (J10-8113-10-00) can be used with the J10 brushes. However, only the J38 springs (J38-8113-10-00) should be used with the J38 brushes.

WARRANTY INFORMATION

This bulletin is issued for informational purposes only. No special warranty applies.

ROUTE TO: SERVICE PARTS WARRANTY SALES PAGE 1 OF 1

ALL GAS-POWERED MODELS PRIMARY CLUTCH WEIGHT LINK WEAR

INTRODUCTION

PROBLEM: Some units in the affected ranges may experience premature wear of the primary clutch weight link assemblies. This usually occurs on units which accumulate high mileage, such as are used as industrial vehicles or fleet cars in high-usage areas.

CAUSE: Grease on the clutch weight links collects dirt which wears the clutch weight link bushings and pins.

REMEDY: Inspect, lubricate, and clean the area during routine maintenance. Install improved weight link kits and replace the pins if excess wear is found.

DEALER ACTION SUMMARY

- Add inspection, lubrication, and cleaning of the primary clutch to the annual service procedures.
- If any unit experiences worn primary clutch weight links, install three improved weight link kits and replace the link pins.
- File a service-per-bulletin warranty request for any repair.

NOTE: Some of the common signs of worn weight links are squeaking, vibration, or rattling from the primary clutch.

AFFECTED UNITS

G1AM J31-140101 ~ 154371	G2AB J38-020101 ~ 039489
G2AAS J38-020101 ~ 006999	J38-071101 ~ 072305
G2A J38-007101 ~ 049999	G3-A J42-000101 ~ 002818
J38-066101 ~ 070999	

SERVICE PROCEDURES

PERIODIC INSPECTION

- Open the rear cowling, and remove the drive belt.
- Remove the primary clutch cap screw, and the clutch cap.
- Inspect the sliding sheave for smooth operation. Check for play between the pivot pins and weight link assemblies.

NOTE: If the pins and weight link assemblies are not worn, and the sliding sheave operates smoothly, remove any dirt and old grease, and apply two to three shots of molybdenum disulfide grease to the grease fitting to lubricate the shaft. Remove any excess grease from the clutch and reassemble the unit. Greasing should be done only with clutch cap removed.



(For additional information see reverse side)

TECHNICAL BULLETIN

SERVICE PROCEDURES (Cont'd.)

CAUTION: Make sure the clutch assembly is free of grease, oil, and dirt. Dirt will adhere to any grease or oil left on the clutch. This is the primary cause of premature wear of both the weight link bushings and pins, and the slider bushings.

• If any of the pins or weight link assemblies are worn, install three weight link kits and its pins.

WEIGHT LINK INSTALLATION

- Disassemble the primary clutch according to the instructions in the service manual.
- Follow the service manual and install the new links and pins. Do not lubricate these parts.
- Apply molybdenum disulfide grease to the grease fitting if necessary, remove any excess, and reassemble the unit.

NOTE: The link kit contains different parts than were removed during disassembly. You must use the illustration in this bulletin to make sure the new parts are installed correctly.

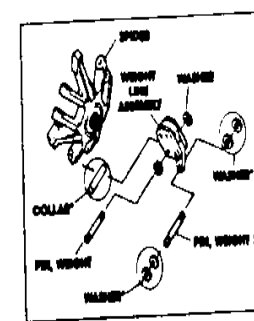
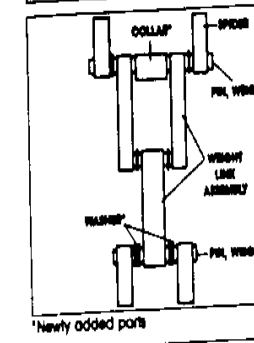
PARTS INFORMATION

Part Number	Description	Qty	Remarks	Dealer Cost
99999-01831-00	Weight link kit	3	For G1-A and G3-A models	\$18.00
99999-01830-00	Weight link kit	3	For G2-A models	17.55
J38-46236-00-00	Pin, Weight	3	For all models	.70
J38-46237-00-00	Pin, Weight 2	3	For all models	.70

NOTE: Make sure the correct weight link kits are ordered (these kits contain the necessary collar and washers). Order three of the correct weight link kits and three of each of the two different pins for each unit.

WARRANTY INFORMATION

There is no warranty allowance for routine maintenance which includes inspection, cleaning, and lubrication.

Labor allowance for installing the weight link kit is 0.7 hours. The problem code is 90JD to receive credit. Follow normal service-per-bulletin procedures.

90JD 0.7

ROUTE TO: SERVICE PARTS WARRANTY SALES PAGE 3 OF 3

TECHNICAL BULLETIN

GOLF CAR Jan 21 88 G44-002

G2 SEAT COVER INSPECTION AND REPAIR

INTRODUCTION

PROBLEM Hole in the seat cover on the side by the driver's side armrest.

REMEDY Remove the staples and or replace the seat cover if it is damaged by incorrect staple placement.

CAUSE Some of the staples used to secure the seat cover to the seat base near the armrest mount may wear through the seat foam and puncture the cover.

DEALER ACTION SUMMARY

For units with no seat cover damage, both new unold units and units already in service, remove the staples near the armrest side of the seat as shown in this bulletin. For sold and registered units with seat cover damage

caused by incorrect stapling, replace seat cover. Use 1/4" stainless steel staples when installing new cover. Follow standard 90 code procedures to file a warranty claim.

AFFECTED UNITS

G2AM6 J38-000101 ~ 006999 G2EM6 J41-000101 ~ 009999
G2A J38-007101 ~ 019999 G2E J41-016101 ~ 029999
J38-066101 ~ 070999 G2EB J41-030101 ~ 033601
G2AB J38-020101 ~ 039499

SERVICE PROCEDURES

WARNING

Wear proper eye protection when performing the procedures described in this bulletin.

Staple Removal Only (if no damage is present)

NOTE: Additional pre-delivery service: pull driver's side staple before assembling new units within the affected range.

1. Raise the seat cowl.
2. Open the mid-body and remove the 2 bolts securing left side of the seat to the base. Flex the seat base far enough to remove the staples near the arm rest mount on the driver's side.
3. Remove only the staple in the affected arm rest mounting area on the seat base.
4. Reinstall the seat.

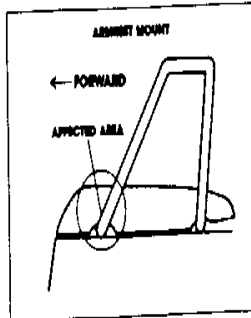

SERVICE PROCEDURE (Cont'd)

Damaged Seat Cover Replacement

1. Raise the seat cowl.
2. Remove the seat.
3. Cut the seat cover between the staples and the seat base edge.

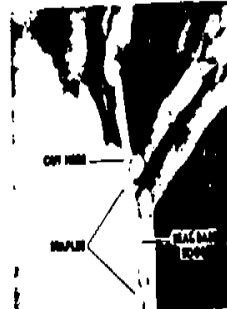

4. Use pliers to pull up the vinyl. When the vinyl is pulled up sharply, most of the staples will be pulled out. Remove any remaining staples in corners and arm rest mounting area. Discard the old seat cover.

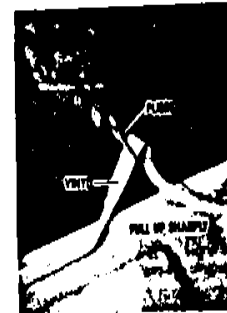

5. Position and center the new seat cover. Staple the centers of the front, rear, left, and right sides to the seat base with a pneumatic or electric staple gun.

6. Fold and staple the corners. Install all other staples (front, back, and sides).

7. Staple the original affected area of the new angle shown in the illustration.

Do not duplicate the original problem.

8. Trim off the excess material.

9. Reinstall the seat.

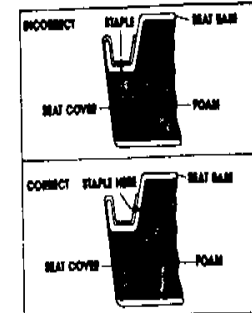

PAGE 1 OF 3

PAGE 2 OF 3

TECHNICAL BULLETIN

GOLF CAR Jan 21 88 G44-002

GOLF CAR Jan 17 88 G44-003

G2-A/G2-E SOLENOID REPAIR KIT

SERVICE PROCEDURE (Cont'd)

PARTS INFORMATION

Part Number	Description	Remarks	Dealer Cost
J38-740A-09-00	Seat cover		
	1/4" stainless steel staples	Obtain from hardware store	

WARRANTY INFORMATION

Staple Removal Only:

For new unold units and registered units with no holes (damage) labor allowance is 0.1 hours.

NOTE 1
0.1
ALL THIS PRODUCT WITH LAST DESCRIPTION IS IN STOCK

Seat Cover Replacement (includes staple removal)

Labor allowance for seat cover replacement is 0.5 hours. Unit must be registered. Yamaha will not reimburse for claims on unregistered units in service or on units registered after 3-31-88.

NOTE 2
0.5
ALL THIS PRODUCT WITH LAST DESCRIPTION IS IN STOCK

ROUTE TO: SERVICE PARTS WARRANTY SALES PAGE 3 OF 3

INTRODUCTION

PROBLEM Solenoid plunger moves, but solenoid does not operate.

is bad if the solenoid plunger does not move when power is applied directly to the solenoid coil wires, or if there is no continuity between the two solenoid coil wires (measured with an ohmmeter with the battery cables and wire harness disconnected.)

CAUSE Internal moving parts or contacts worn or damaged.

REMEDY Install solenoid repair kit.

NOTE: If the solenoid coil is bad, the complete solenoid must be replaced. (The solenoid coil

if the coil is good, the ohmmeter should read 62Ω ± 10% (J-41) or 7Ω ± 10% (J-38). Any higher readings indicate a shorted or grounded coil.

DEALER ACTION SUMMARY

If a solenoid's plunger moves, but the solenoid does not operate properly, a repair kit may be

installed, using the service procedures in the bulletin.

AFFECTED UNITS

All G2-A, J38
All G2-E, J41

SERVICE PROCEDURES

Turn the main switch off, and disconnect the negative battery lead. Secure the battery lead so it cannot contact the battery terminal, and remove the solenoid.

NOTE: Refer to the PARTS INFORMATION section to view all parts named in the following procedures.

DISASSEMBLY

1. Remove the cover screws and loosen the end cap.

CAUTION

Do not try to remove the cap at this point. The coil wires are still attached and will easily break if any strain is put on them.



PAGE 1 OF 4

TECHNICAL BULLETIN

GOLF CAR
 DATE: 1/78 BY: G44-001

DISASSEMBLY (Cont'd.)

- Heat the terminals at the top of the cap to melt the solder that holds the coil wires. Only when the solder is fluid, pull upward on the cap and allow the wires to slip out. Discard the old cap and seal.

CAUTION

Do not pull on the end cap until the solder has melted. The coil wires will break.



- Remove the rubber cover, and underneath, the two screws, the plate, and the two collars.

- Remove the contact plate by removing the small nut holding it to the shaft and plunger assembly.

- Discard the plunger, shaft, and contact plate and parts. Keep the large spring and insulator for use in reassembly.



REASSEMBLY

WARNING

Failure to follow these reassembly and plunger adjustment instructions properly can cause the solenoid to engage by itself, with the following possible consequences:

- ELECTRIC CAR - WITH BRAKE ON:** Overheating of the resistor coils and motor, resulting in serious damage to these components.
- ELECTRIC CAR - WITH BRAKE OFF:** The car may move without an operator.
- GAS CAR - WITH BRAKE ON OR OFF:** The starter motor will operate without the accelerator pedal being pressed. Under certain conditions, the car can move without an operator.

PAGE 2 OF 4

ASSEMBLY (Cont'd.)

- Apply a light coating of high-temperature grease inside the body.
- Install the new shaft assembly in the solenoid body. Then, install the old insulator and spring over the threaded end of the shaft.
- Hold the contact plate to prevent the shaft from turning, and screw the new plunger onto the shaft until it reaches the end of the threads. Then, back it off 1/2 - 3/4 turns.
- Clean the contacts on both the shaft assembly and cap.
- Remove all excess solder from the two coil wires.
- Make sure the wires are straight (Remember, they are very fragile), and carefully install the guide tubes over them.
- Install the new end cap and seal over the guide tubes.
- Remove the guide tubes and discard them. Solder the wires to their terminals.

NOTE: Add Job Code 8025 to your G2-A and G2-E Flat Rate Tables. Labor time is 0.5 hours.



PLUNGER ADJUSTMENT

- Connect a pocket tester (ohms x 1 scale) to the main solenoid terminals as shown. The meter should read ∞.
- Connect a 12 volt battery (G2-A solenoids) to the small terminals as shown. 36 DC volts must be used for G2-E solenoids.

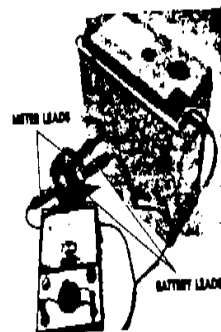

PAGE 3 OF 4

TECHNICAL BULLETIN

PLUNGER ADJUSTMENT (Cont'd.)

- Hold the plunger so it does not turn. Insert a screwdriver into the slot in the shaft, and turn the shaft clockwise until the needle on the tester just starts to move. Then, turn the shaft another 1 ± 1/8 turn clockwise. This will set the plunger so there is about a 1mm overstroke. The ohmmeter should read zero. Disconnect the battery and meter leads.

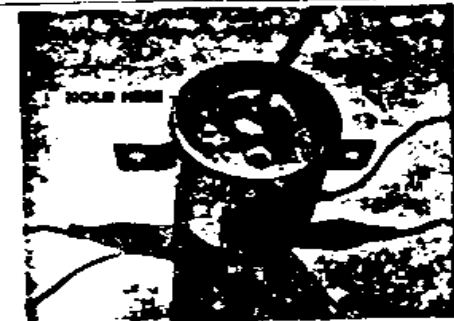

- Slide the shaft screw slot by squeezing the collar around it in a vise or with a pair of pliers to prevent the shaft from turning.

- Install the collars, the plate, the screws, and the rubber cover.

- Reinstall the solenoid, and check solenoid operation.

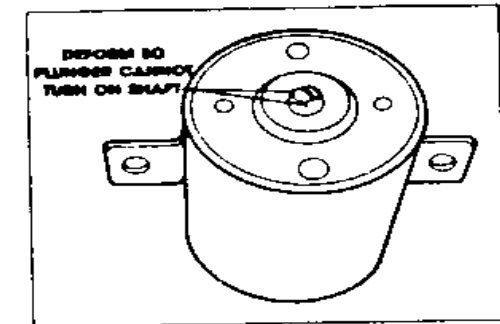

PARTS INFORMATION

- | | |
|-------------------|----------------------|
| 1 End Cap* | 8 Spring* |
| 2 Seal* | 9 Collar* |
| 3 Shaft Assembly* | 10 Collar* |
| 3A Shaft Nut | 11 Screws for Plate* |
| 3B Contact Plate | 12 Rubber Cover* |
| 4 Plunger* | 13 Guide Tubes* |
| 5 Screws for Cap* | |
| 6 Solenoid Body* | |
| 7 Insulator* | |

*Part of repair kit.
 *Reuse these parts.

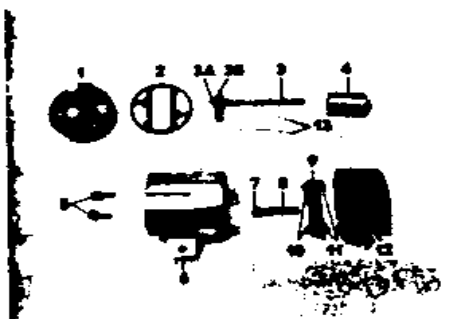

Part Number	Description	Qty	Dealer Cost
J41-81920-09-00	Solenoid Repair Kit	1	
	End Cap	1	
	End Cap Seal	1	
	Shaft Assembly	1	
	Plunger	1	
	Guide Tubes	2	

WARRANTY INFORMATION

This bulletin is issued for informational purposes only. No special warranty applies.

PAGE 4 OF 4

ROUTE TO

SERVICE

PARTS

WARRANTY

SALES

TECHNICAL BULLETIN

GOLF CAR Jan 9 21 89 In G89-007

G2-A SECONDARY SHEAVE SPRING SEAT SPACER

INTRODUCTION

PROBLEM Poor acceleration and/or decreased hill climbing ability on some high mileage cars or cars used in hilly areas. The performance may eventually deteriorate to the point that the car will not move.

input shaft may wear allowing the spring seat to move. This causes the sheaves to spread and the clutch to function improperly.

REMEDY Replace the spring seat circlip with the new spacer.

CAUSE The secondary sheave spring seat circlip and circlip groove on the transmission

DEALER ACTION SUMMARY

MODIFY Any units in affected range with the problem

PARTS REQUIRED Yes
WARRANTY Normal Warranty Applies

AFFECTED UNITS

G2A J38-007001 ~ 099999
066001 ~ 070999
G2AB J38-020001 ~ 099999
071001 ~ 089999

G2AC JA2-000001 ~ 099999
G2AD J55-000001 ~ 029999
G2AF J55-100001 ~ 104600

SERVICE PROCEDURES

1 Follow service manual instructions to remove the rear body and the secondary clutch fixed sheave.

2 Remove the plastic washer, woodruff key, sliding sheave, and spring seat. Remove the circlip. Tag the circlip with a Warranty Parts tag and hold for 90 days from the date the Warranty Request is submitted. The circlip is not used with the new spacer.

3 Install the new secondary sheave spring seat spacer on the input shaft with the inside splined side of the spacer towards the spring seat. DO NOT REINSTALL THE CIRCLIP.

4 Reinstall the secondary spring seat and reassemble the secondary sheave assembly according to the service manual procedures. Use a new cotter pin.

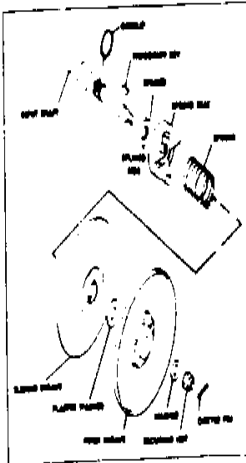

NOTE: Pay special attention to the service manual procedures for installing the spring and sliding sheave. Correct installation of the spring and sliding sheave is critical for proper operation.

PARTS INFORMATION

Part Number	Description	Dealer Cost
J55-46322-09-00	Spacer input shaft	\$11.25
01401-25025-00	Cotter Pin	.25

WARRANTY INFORMATION

Submit a normal warranty request. The warranty labor allowance for this repair is 0.3 hour. The Job Code is 701. The Problem Code is 49. Fill in the circled information and include the other information as illustrated.

YAMAHA		Warranty Request Worksheet	
1. Part Number	2. Description	3. Dealer Cost	4. Job Code
J55-46322-09-00	Spacer input shaft	\$11.25	701
01401-25025-00	Cotter Pin	.25	
5. Problem Code		6. Problem Description	
49		Fuel tank pressure release valve stuck in the closed position. Possible symptoms are carburetor overflowing, contamination of crankcase oil and air filter.	
7. Date of Repair		8. Dealer Name	
9/14/01		2501500001	
9. Mileage at Repair		10. Mileage at Return	
11. Name of Customer		12. Name of Dealer	
13. Name of Technician		14. Name of Supervisor	
15. Name of Approver		16. Name of Customer	
17. Name of Dealer		18. Name of Approver	
19. Name of Approver		20. Name of Approver	
21. Name of Approver		22. Name of Approver	
23. Name of Approver		24. Name of Approver	
25. Name of Approver		26. Name of Approver	
27. Name of Approver		28. Name of Approver	
29. Name of Approver		30. Name of Approver	
31. Name of Approver		32. Name of Approver	
33. Name of Approver		34. Name of Approver	
35. Name of Approver		36. Name of Approver	
37. Name of Approver		38. Name of Approver	
39. Name of Approver		40. Name of Approver	
41. Name of Approver		42. Name of Approver	
43. Name of Approver		44. Name of Approver	
45. Name of Approver		46. Name of Approver	
47. Name of Approver		48. Name of Approver	
49. Name of Approver		50. Name of Approver	
51. Name of Approver		52. Name of Approver	
53. Name of Approver		54. Name of Approver	
55. Name of Approver		56. Name of Approver	
57. Name of Approver		58. Name of Approver	
59. Name of Approver		60. Name of Approver	
61. Name of Approver		62. Name of Approver	
63. Name of Approver		64. Name of Approver	
65. Name of Approver		66. Name of Approver	
67. Name of Approver		68. Name of Approver	
69. Name of Approver		70. Name of Approver	
71. Name of Approver		72. Name of Approver	
73. Name of Approver		74. Name of Approver	
75. Name of Approver		76. Name of Approver	
77. Name of Approver		78. Name of Approver	
79. Name of Approver		80. Name of Approver	
81. Name of Approver		82. Name of Approver	
83. Name of Approver		84. Name of Approver	
85. Name of Approver		86. Name of Approver	
87. Name of Approver		88. Name of Approver	
89. Name of Approver		90. Name of Approver	
91. Name of Approver		92. Name of Approver	
93. Name of Approver		94. Name of Approver	
95. Name of Approver		96. Name of Approver	
97. Name of Approver		98. Name of Approver	
99. Name of Approver		100. Name of Approver	

PAGE 2 OF 2 ROUTE TO SERVICE PARTS WARRANTY SALES

PAGE 1 OF 2

TECHNICAL BULLETIN

GOLF CAR Jan 3 23 89 In G89-002

G2A FUEL TANK PRESSURE RELEASE VALVE REPLACEMENT

INTRODUCTION

PROBLEM Fuel tank pressure release valve stuck in the closed position. Possible symptoms are carburetor overflowing, contamination of crankcase oil and air filter.

CAUSE Fuel residue may cause the fuel tank pressure release valve to stick in the closed position, causing the carburetor to overflow.

REMEDY If the affected release valve is stuck closed, replace it with a new style valve.

DEALER ACTION SUMMARY

Affected pressure release valves are white in color; new replacement valves are black. On affected units, perform the procedure outlined in this bulletin. File a normal warranty request.

AFFECTED UNITS

G2A J38-000001 ~
JA2-000001 ~
J55-000001 ~ 001606

SERVICE PROCEDURE

WARNING

Gasoline and its vapor are highly flammable, explosive and poisonous. Keep fuel away from sparks, lit cigarettes, or flames. Work in a well ventilated area.

1. Open the fuel tank access lid, pull up the lever to unhook the seat lock, and open the seat covering.

2. Pull the valve straight up to remove it from the top of the fuel tank.

3. Connect the valve to a short length of appropriate sized hose. Test for blockage by blowing air through the hose by mouth. If no air passes through it, replace with an updated valve.

PARTS INFORMATION

Part Number	Description	Remarks	Dealer Cost
J24-24460-01-00	Pressure release valve	G2A	

PAGE 1 OF 2

WARRANTY INFORMATION

Normal warranty procedure applies. There is no Job Code. The Problem Code is 21. Flat rate time for this job is 0.1 hours. Enter the following information on lines 10, 11, 13, 14, and 15 on the Warranty Request.

10. Use any spare labor (in hours) and give the reason for the request. 0.1

11. Reason: NO JOB CODE

12. Use any related labor and attach the receipt. 0.1

13. What was the problem? Describe the symptoms prior to repair: Carburetor Overflowing

14. Describe the defect in materials parts or workmanship: Pressure release valve stuck closed

15. What was done to repair the defect? What action was taken to remedy the problem: Replace pressure release valve per bulletin # 899-002.

PAGE 2 OF 2 ROUTE TO SERVICE PARTS WARRANTY SALES