

YAMAHA



PARTS CATALOG

1996 G16AR

1997 G16AR

1998 G16AS

1999 G16AT

2000 G16AU

2001 G16AW

(JN62) U.S.A., CANADA, EUROPE, OTHERS



FOREWORD

This Parts Catalogue is related to the parts for the model(s) shown in the frame below. When you are ordering replacement parts, please refer to this Parts Catalogue and quote both part numbers and part names correctly.

G16A (JN61, JN62)

1. Modifications or additions which have been made after issue of the Parts Catalogue will be announced in the Yamaha Parts News. It is advisable that you make necessary corrections to the Parts Catalogue according to the Yamaha Parts News.

2. Abbreviations

The following abbreviations are used in this Parts Catalogue.

"UR" Use specified part number.

"UN" Use as many as needed.

"AP" Alternate parts.

"LM" Local Made (Parts need to be ordered locally)

"F#" Frame Number (Applicable machine number)

3. Parts, which are to be supplied in an assembly, are listed with a dot (.) in front of the part name as shown below.

EXAMPLE
 CARBURETOR ASSY
 .JET, PILOT
 .NOZZLE, MAIN

4. Number of component for assembly

The numeral appearing to the right of each component part indicates the quantity of parts for each assembly unit.

EXAMPLE

PART NO.	DESCRIPTION	Q'TY	REMARKS
2F5-83310-60	FRONT FLASHER LIGHT ASSY	2	
115-83311-60	.BULB (6V-18W)	1	

5. Applicable colors of graphics are represented in the "REMARKS" as shown below.

PART NO.	DESCRIPTION	Q'TY	REMARKS
2N4-24110-00-X5	FUEL TANK COMP.	1	MAXIM RED
3J1-24240-10	.GRAPHIC, FUEL TANK	1	for MXR

6. Applicable Serial No. and Color Code

① Frame Serial No. JN6-000101 ~

② Engine Serial No. JN6-000101 ~

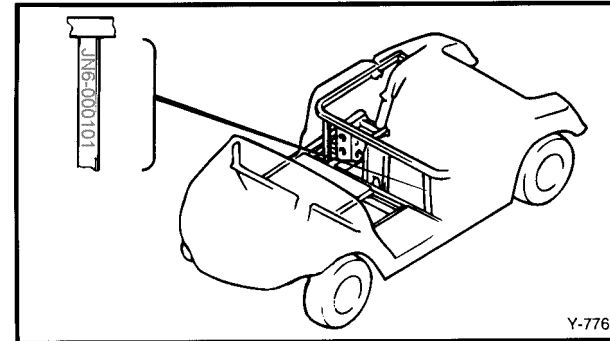

① Frame Serial No. JN6-300101 ~

② Engine Serial No. JN6-300101 ~

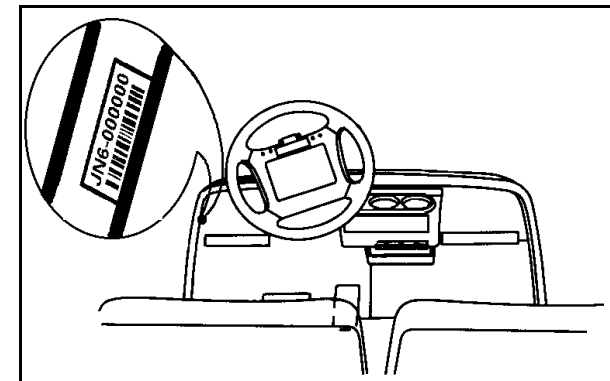

7. Note that the illustrations are for reference in finding parts numbers, not to be used for assembling. When assembling, please use the applicable service manual.

8. The asterisk (*) before a reference number indicates modification items after the first edition.

CONTENTS

ENGINE	PAGE		PAGE
Engine Assembly	5	Secondary Sheave	30
Cylinder Head	6	Transmission	31 ~ 33
Crankshaft / Piston	7	Rear Axle Mount / Wheel	34
Camshaft / Valve	8	Shifter / Cables	35
Air Shroud / Fan	9	Bumper	36
Intake	10	Body (Front)	37 ~ 38
Carburetor	11	Body 2 (Rear)	39 ~ 40
Exhaust	12	Body Fitting	41
Crankcase	13	Carrier	42
		Seat	43 ~ 44
CHASSIS		Starter Generator	45 ~ 46
Engine Mount	14	Electrical 1	47
Rear Arm / Suspension	15	Electrical 2	48 ~ 49
Frame	16	Optional Seat Adjuster	50
Front Suspension / Wheel	17 ~ 18	Optional Hub Caps	51
Steering	19 ~ 20	Optional Draw Bar	52
Fuel Tank	21	Optional Windshield	53
Brake	22 ~ 24	Optional Sunroof	54
Brake 2	25	Optional Ornament Plate	55
Brake 3	26	Optional Fleet Numbers	56 ~ 57
Accelerator	27	Optional Sand Bottle / Rake	58
Governor	28	Optional Light Kit	59
Primary Clutch	29	Optional Enclosure	60

FIG. 1 ENGINE ASSEMBLY

REF NO.	PART NUMBER	DESCRIPTION	QTY	REMARKS
1	JR3-19001-00-00	ENGINE ASSEMBLY	1	

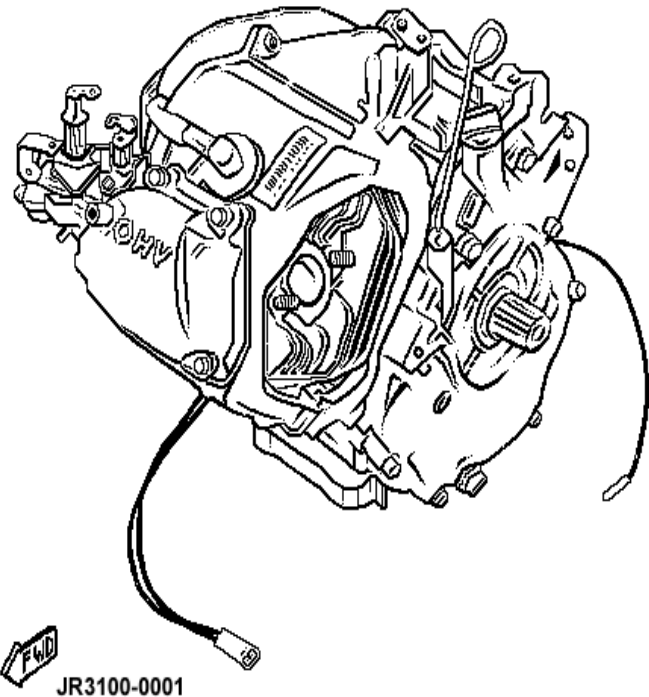

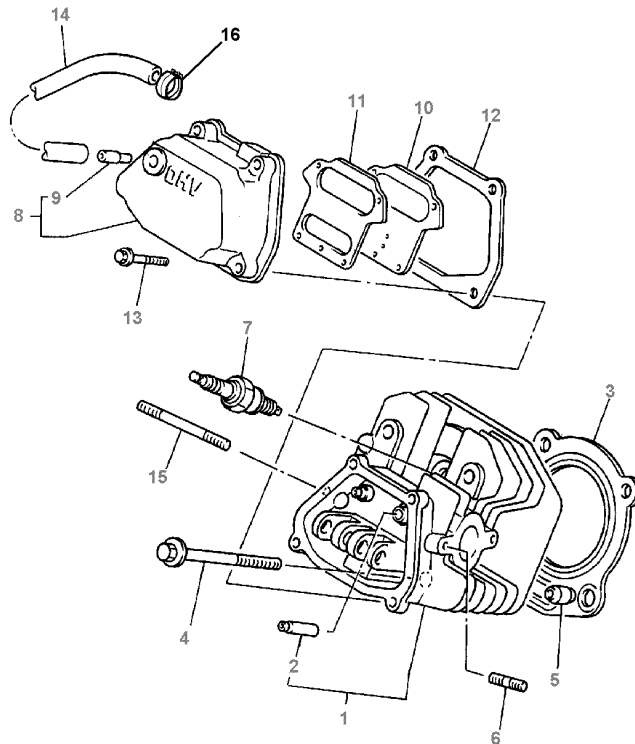

JN7010-6011

FIG. 2 CYLINDER HEAD

REF NO.	PART NUMBER	DESCRIPTION	QTY	REMARKS
1	JN6-11102-00-00	HEAD, CYLINDER	1	
2	JN6-11133-10-00	.GUIDE, VALVE	2	
3	JN6-11181-00-00	GASKET, CYLINDER HEAD	1	
4	95817-10070-00	BOLT, FLANGE	4	
5	99530-14016-00	PIN, DOWEL A	2	
6	95617-08618-00	BOLT, STUD	2	
7	NGK-BPR2E-S0-00	PLUG, SPARK	1	STD, U.S.
	94702-00348	PLUG, SPARK	1	STD, EUROPE
	NGK-BPR4E-S0-00	PLUG, SPARK	1	AP, U.S.
	94702-00343	PLUG, SPARK	1	AP, EUROPE
8	JN6-11191-01-00	COVER, CYLINDER	1	
9	JN6-11116-00-00	.JOINT, BREATHER	1	
10	JN6-11168-00-00	COVER, BREATHER	1	
11	JN6-11169-00-00	GASKET, BREATHER	1	
12	JN6-11193-00-00	GASKET, HEAD COVER	1	
13	95817-06030-00	BOLT, FLANGE	4	
14	JN6-E1166-00-00	PIPE, BREATHER	1	
15	95617-08710-00	BOLT, STUD	2	
16	90467-13847-00	CLAMP	2	F# JN6-006700~

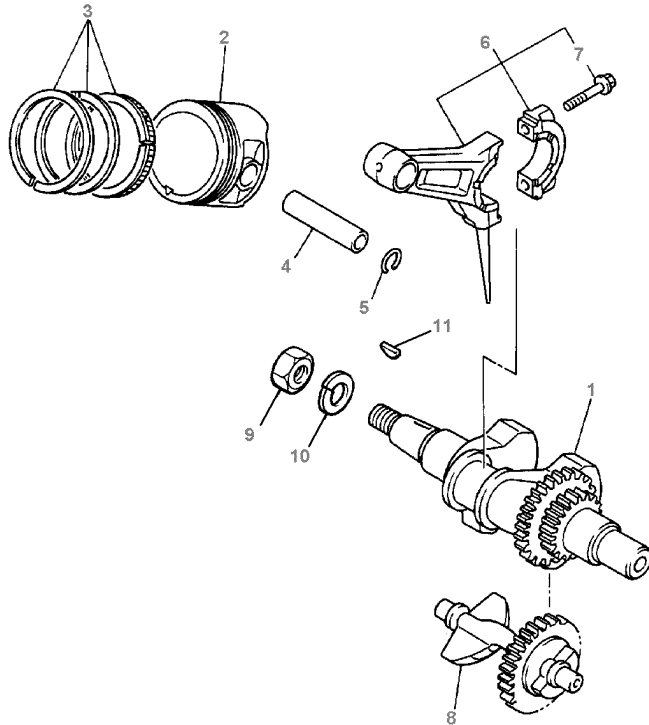

FIG. 3 CRANKSHAFT / PISTON

REF NO.	PART NUMBER	DESCRIPTION	QTY	REMARKS
1	JN6-11400-00-00	CRANK ASSY.	1	
2	JN6-11631-00-A0	PISTON, (STD)	1	STD
	JN6-11635-00-00	PISTON, (0.25mm O/S)	1	AP
	JN6-11636-00-00	PISTON (0.50mm O/S)	1	AP
3	JN6-11610-00-00	PISTON RING SET, STD.	1	STD
	JN6-11610-10-00	PISTON RING SET, (0.25mm O/S)	1	AP
	JN6-11610-20-00	PISTON RING SET, (0.50mm O/S)	1	AP
4	447-11633-00-00	PIN, PISTON	1	
5	93450-21053-00	CIRCLIP	2	
6	JN6-11650-00-00	CONNECTING ROD ASSY	1	
7	JN6-11654-00-00	.BOLT, CONNECTING ROD	2	
8	JN6-11454-00-00	WEIGHT, 1	1	
9	95317-18600-00	NUT, HEX.	1	
10	90201-18620-00	WASHER, PLAIN	1	
11	90280-04052-00	KEY, WOODRUFF	1	



JN7010-6020

FIG. 4 CAMSHAFT / VALVE

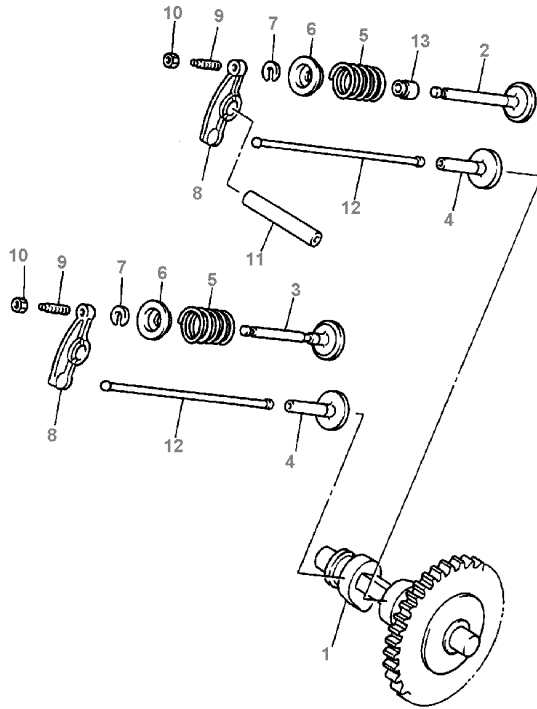

REF NO.	PART NUMBER	DESCRIPTION	QTY	REMARKS
1	JN6-12171-00-00	SHAFT, CAM 1	1	
2	JN6-12111-01-00	VALVE, INTAKE	1	
3	JN6-12121-00-00	VALVE, EXHAUST	1	
4	JN6-12153-00-00	LIFTER, VALVE	2	
5	90501-264A9-00	SPRING, COMPRESSION	2	
6	J38-12117-01-00	RETAINER, VALVE SPRING	2	
7	J38-12118-00-00	LOCK, VALVE SPRING	2	
8	JN6-12151-00-00	ARM, VALVE ROCKER	2	
9	22F-12159-00-00	SCREW, VALVE	2	
10	90170-05302-00	NUT, HEX.	2	
11	J38-12156-00-00	SHAFT, ROCKER	1	
12	JN6-12154-00-00	ROD, VALVE PUSH	2	
13	5H0-12119-00-00	SEAL, VALVE STEM	1	

 JN7010-6030

FIG. 5 AIR SHROUD / FAN

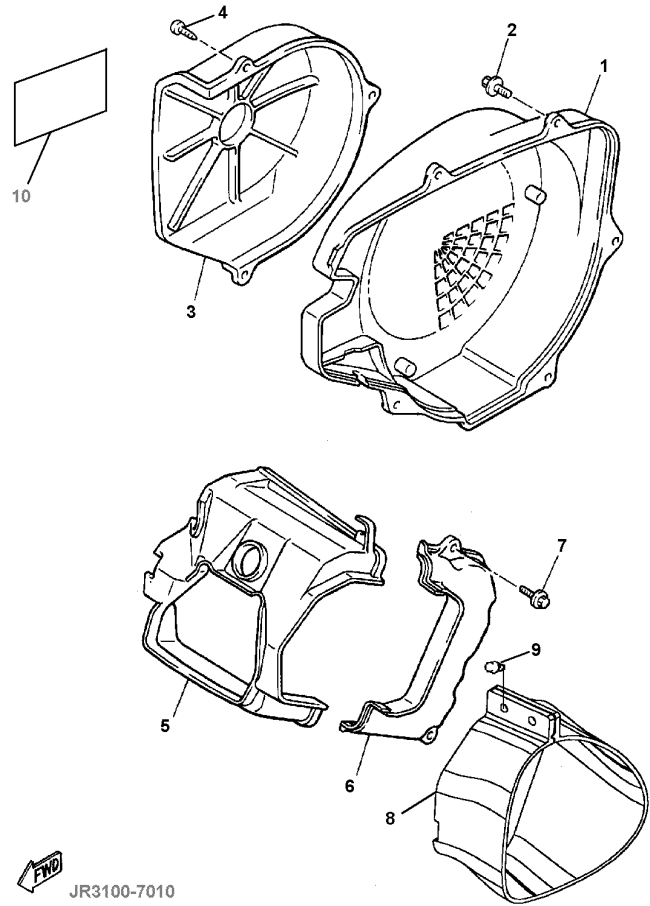

 JR3100-7010

REF NO.	PART NUMBER	DESCRIPTION	QTY	REMARKS
1	JN6-12621-00-00	CASE, FAN 1	1	
2	95817-06020-00	BOLT, FLANGE	5	
3	JN6-12616-00-00	COVER, FAN CASE	1	
4	97707-60520-00	SCREW, PAN HEAD	3	
5	JN6-12651-00-00	AIR SHROUD, CYLINDER 1	1	
6	JN6-12652-00-00	AIR SHROUD, CYLINDER 2	1	
7	95817-06020-00	BOLT, FLANGE	2	
8	JN6-E2691-00-00	DUCT, 1	1	
9	90269-08813-00	RIVET	2	
10	JR3-2179R-03-00	PLATE, EPA / CALIF.	1	UR, U.S. MODEL

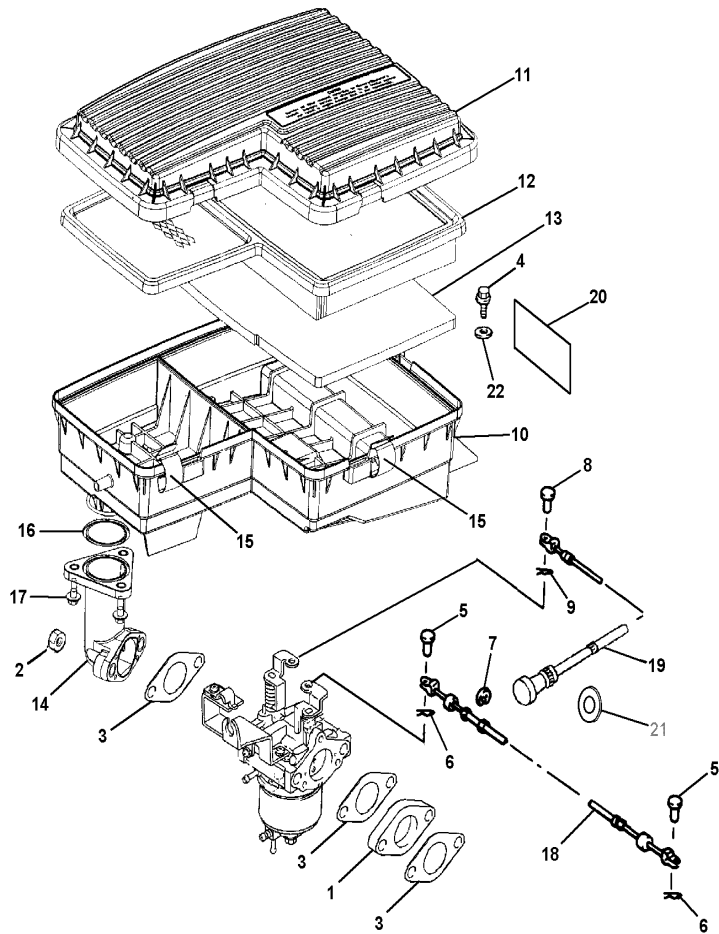

 JN6200-7010

FIG. 6 INTAKE

REF NO.	PART NUMBER	DESCRIPTION	QTY	REMARKS
1	JN6-13595-00-00	JOINT	1	
2	95707-08500-00	NUT, FLANGE	2	
3	JN6-13567-00-00	GASKET	3	
4	90119-06920-00	BOLT, HEX HEAD W/WASHER	2	
5	91790-05010-00	PIN, CYL. HEAD	2	
6	90468-10050-00	CLIP	2	
7	99080-07600-00	CIRCLIP (E)	1	
8	91790-05010-00	PIN, CYL. HEAD	1	
9	90468-10050-00	CLIP	1	
10	JN6-E4411-02-00	CASE, AIR FILTER	1	SEE NOTE "A"
11	JN6-E4412-01-00	CAP, CASE 1	1	
12	JN6-E4450-01-00	ELEMENT ASSY.	1	
13	JN6-E445E-00-00	FILTER, 1	1	
14	JN6-E3586-01-00	JOINT, CARBURETOR	1	
15	JN6-E4424-00-00	CLIP, CAP FIT	5	
16	93210-398D6-00	O-RING	1	
17	90105-06862-00	BOLT, FLANGE	3	
18	JN6-F6312-01-00	WIRE, THROTTLE	1	
19	JN6-F6331-00-00	WIRE, STARTER	1	
20	JN6-K7761-10-00	LABEL, WARNING 1	1	SEE NOTE "A"
21	90201-118N2-00	WASHER, PLAIN	1	

NOTE "A": When replacing "Case Air Filter JN6-E4411-02-00" you must also replace "Label Warning 1 JN6-K7761-10-00".

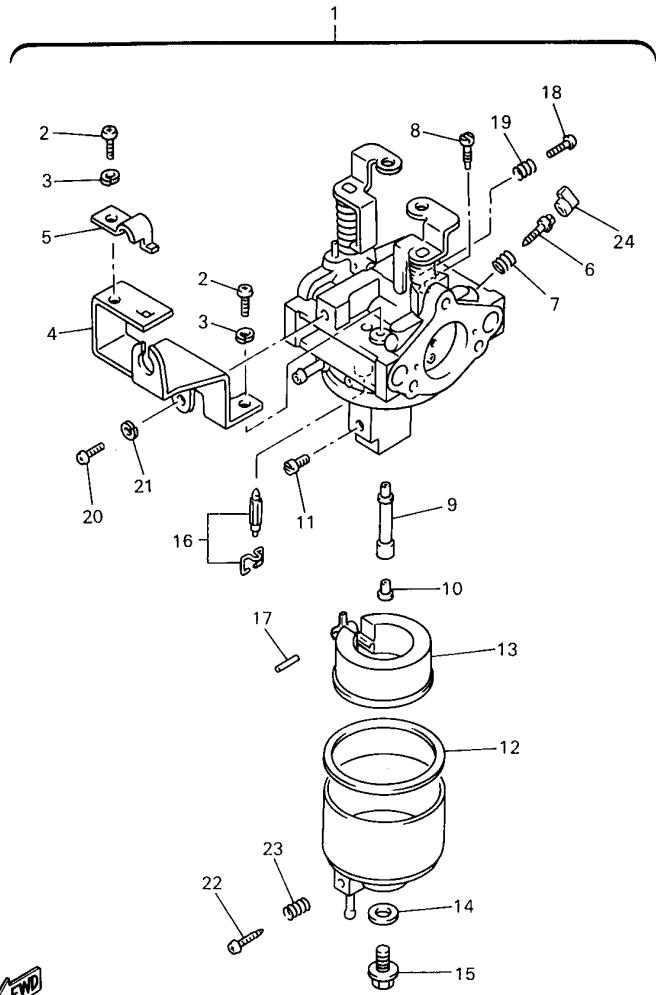

JR2010-7060

FIG. 7 CARBURETOR

REF NO.	PART NUMBER	DESCRIPTION	QTY	REMARKS
1	JN6-14101-14-00	CARBURETOR ASSY.	1	UR, F# JN6-216891~
2	98507-05100-00	.SCREW, PAN HEAD	2	
3	92990-05100-00	.WASHER	2	
4	JN6-14291-00-00	.BRACKET 1	1	
5	J10-14227-00-00	.WASHER	1	
6	7LV-14211-00-00	.SCREW, PILOT ADJUSTING	1	
7	73A-14212-00-00	.SPRING, PILOT ADJUSTING	1	
8	620-1414J-24-00	.JET, PILOT	1	(#61.3)
9	JN6-1495H-3B-00	.NOZZLE, MAIN	1	
10	73A-1414G-00-00	.PIPE, MAIN BLEED	1	
11	3G2-1423E-33-00	.JET, MAIN	1	(#83.8)
12	796-14184-00-00	.GASKET, FLOAT CHAMBER	1	
13	JN6-14185-00-00	.FLOAT	1	
14	127-14198-00-00	.GASKET	1	
15	7R1-14162-00-00	.BOLT, HOLDING	1	
16	JN5-14150-00-00	.NEEDLE ASSY	1	
17	22F-14186-00-00	.PIN, FLOAT	1	
18	1WG-14922-00-00	.SCREW, THROTTLE	1	
19	73A-14212-10-00	.SPRING	1	
20	98507-04010-00	.SCREW, PAN HEAD	1	
21	92990-05100-00	.WASHER	1	
22	7E1-14191-00-00	.PLUG, DRAIN	1	
23	73A-14212-00-00	.SPRING	1	
24	7LV-14118-00-00	.CAP	1	
	1K7-14197-01-00	.VENT HOSE	1	F# JN6-216891~

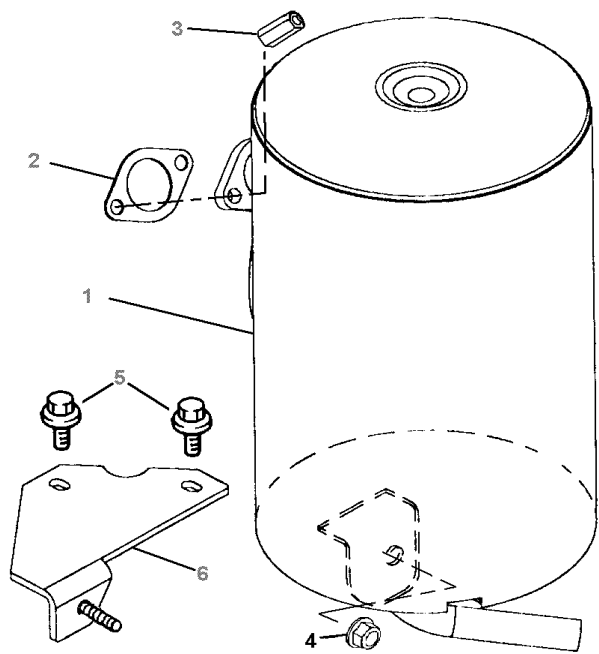

 JN6100-6021

FIG. 8 EXHAUST

REF NO.	PART NUMBER	DESCRIPTION	QTY	REMARKS
1	JN6-E4710-00-00	MUFFLER ASSEMBLY	1	
2	7KY-14613-01-00	GASKET, EXHAUST 1	1	
3	90179-08879-00	NUT	2	
4	90185-08841-00	NUT, U-FLANGE	1	
5	90119-08825-00	BOLT, HEX HEAD W/WASHER	2	
6	JN6-F1435-10-00	BRACKET, MUFFLER	1	

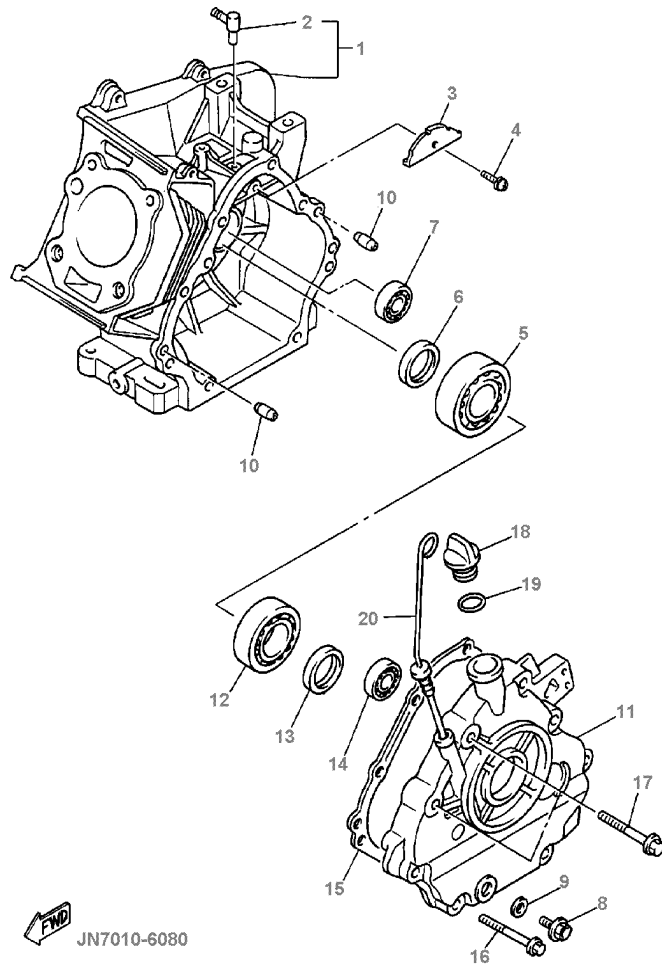
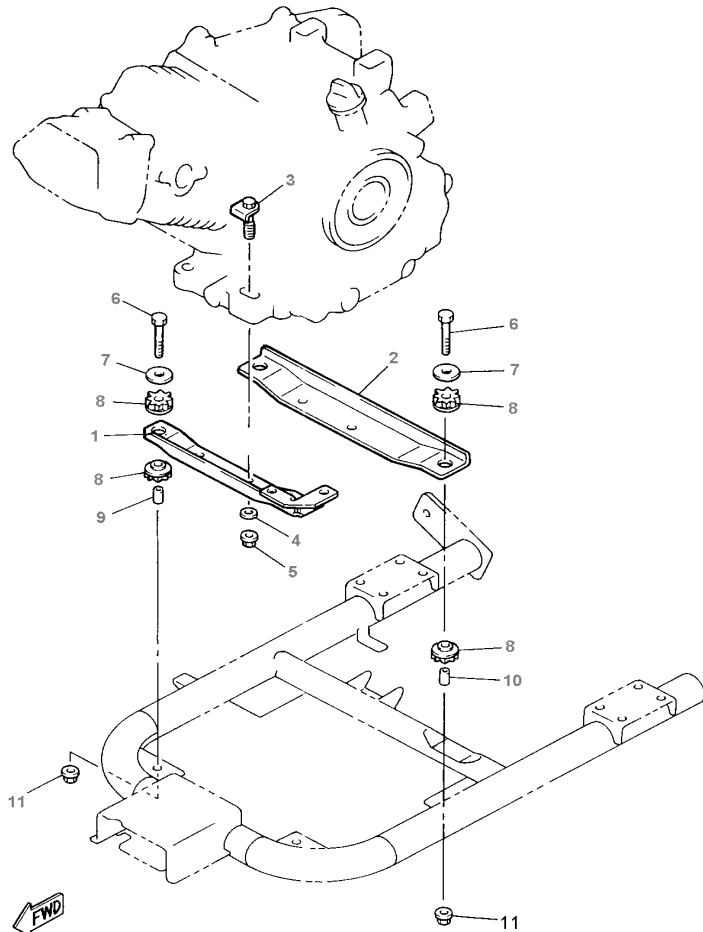

FIG. 9 CRANKCASE

REF NO.	PART NUMBER	DESCRIPTION	QTY	REMARKS
1	JN6-15100-02-00	CRANKCASE ASSY	1	
2	JN6-15155-00-00	.NOZZLE, 3	1	
3	JN6-15123-00-00	PLATE, BAFFLE	1	
4	90159-06107-00	SCREW, W/WASHER	1	
5	93306-30709-00	BEARING	1	
6	93102-35191-00	SEAL, OIL	1	
7	93306-20211-00	BEARING	1	
8	90340-12097-00	PLUG, STRAIGHT	1	
9	812-11198-00-00	GASKET	1	
10	91808-16023-00	PIN, DOWEL A	2	
11	JN6-15411-00-00	COVER, CRANKCASE	1	
12	93306-20716-00	BEARING	1	
13	93102-35191-00	SEAL, OIL	1	
14	93306-20211-00	BEARING	1	
15	JN6-15451-02-00	GASKET, CRANKCASE	1	
16	95817-08045-00	BOLT, FLANGE	6	
17	95817-10050-00	BOLT, FLANGE	2	
18	796-15363-01-00	PLUG, OIL	1	
19	93210-22344-00	O-RING	1	
20	J38-15361-00-00	GAUGE, LEVEL	1	



JR2010-7090

FIG. 10 ENGINE MOUNT

REF NO.	PART NUMBER	DESCRIPTION	QTY	REMARKS
1	JN6-F1411-00-00	BRACKET, ENGINE 1	1	
2	JN6-F1419-00-00	BRACKET, ENGINE 2	1	F# JN6-000101~008709
	JN6-F1419-02-00	BRACKET, ENGINE 2	1	F# JN6-008710 ~ SEE NOTE "A"
3	JN6-F1481-00-00	BOLT, ENGINE	4	
4	92907-10200-00	WASHER, PLAIN	4	
5	95607-10200-00	NUT, U-FLANGE	4	
6	90101-08870-00	BOLT, HEX	4	
7	90201-088K6-00	WASHER, PLAIN	4	
8	JN6-F1486-00-00	DAMPER, 2	8	
9	JN6-F1459-00-00	SPACER	2	
10	JN6-F1459-00-00	SPACER	2	F# JN6-000101~008709
	JN6-F1459-10-00	SPACER	2	F# JN6-008710~ SEE NOTE "A"
11	95617-08200-00	NUT, U-FLANGE	4	

NOTE "A": Ref. No.'s 2 and 10 must be used as a set if installed on early units, from F# JN6-000101~008709.

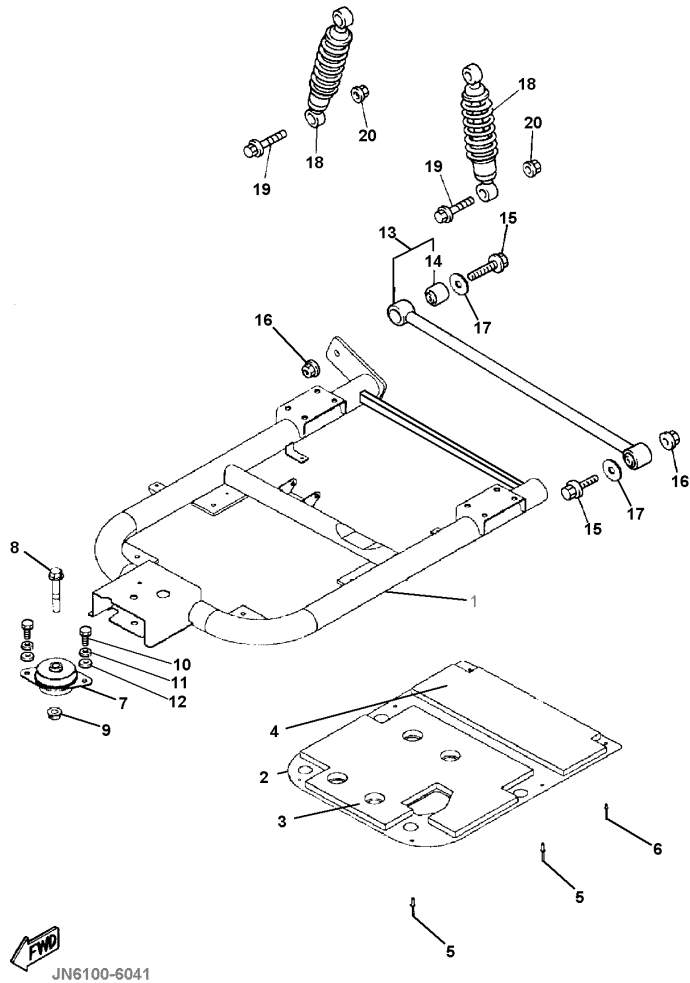
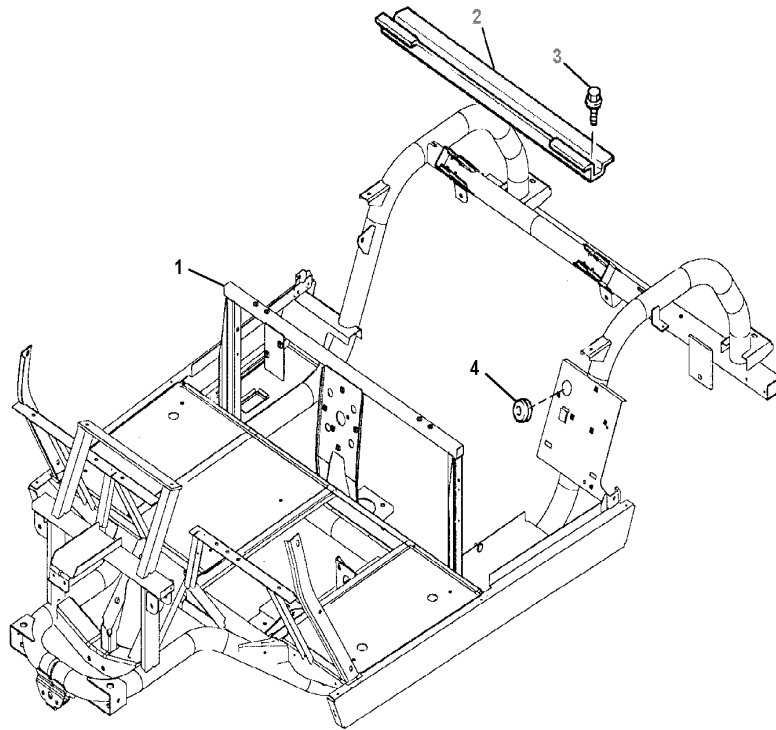

FIG. 11 REAR ARM / SUSPENSION

REF NO.	PART NUMBER	DESCRIPTION	QTY	REMARKS
1	JN6-F2110-01-00	REAR ARM COMP.	1	
2	JN6-F2128-01-00	COVER, 1	1	
3	JN6-F211E-01-00	PANEL, INNER 1	1	
4	JN6-F211G-01-00	PANEL, INNER 2	1	
5	90267-48850-00	RIVET, BLIND	4	
6	90267-40851-00	RIVET, BLIND	2	
7	JN6-F2123-01-00	BUSHING, 1	1	
8	90105-13864-00	BOLT, FLANGE	1	
9	90179-13878-00	NUT	1	
10	97017-10020-00	BOLT, HEX. HEAD	2	
11	92907-10100-00	WASHER, LOCK	2	
12	92907-10600-00	WASHER, PLAIN	2	
13	JN6-F217G-00-00	ROD, CONNECTING	1	
14	JN6-F2124-00-00	BUSHING, 2	2	
15	95817-12065-00	BOLT, FLANGE	2	
16	95617-12200-00	NUT, U-FLANGE	2	
17	90201-12426-00	WASHER, PLAIN	2	
18	JN3-F2210-00-00	SHOCK ABSORBER	2	
19	95807-10055-00	BOLT, FLANGE	4	
20	95607-10200-00	NUT, U-FLANGE	4	

FIG. 12 FRAME



 JN6100-6051

REF NO.	PART NUMBER	DESCRIPTION	QTY	REMARKS
1	JN6-F2501-01-00	FRAME COMP.	1	
2	JN6-F254R-00-00	SUPPORT, BODY MOUNTING	1	
3	95817-08016-00	BOLT, FLANGE	2	
4	90480-25856-00	GROMMET	1	

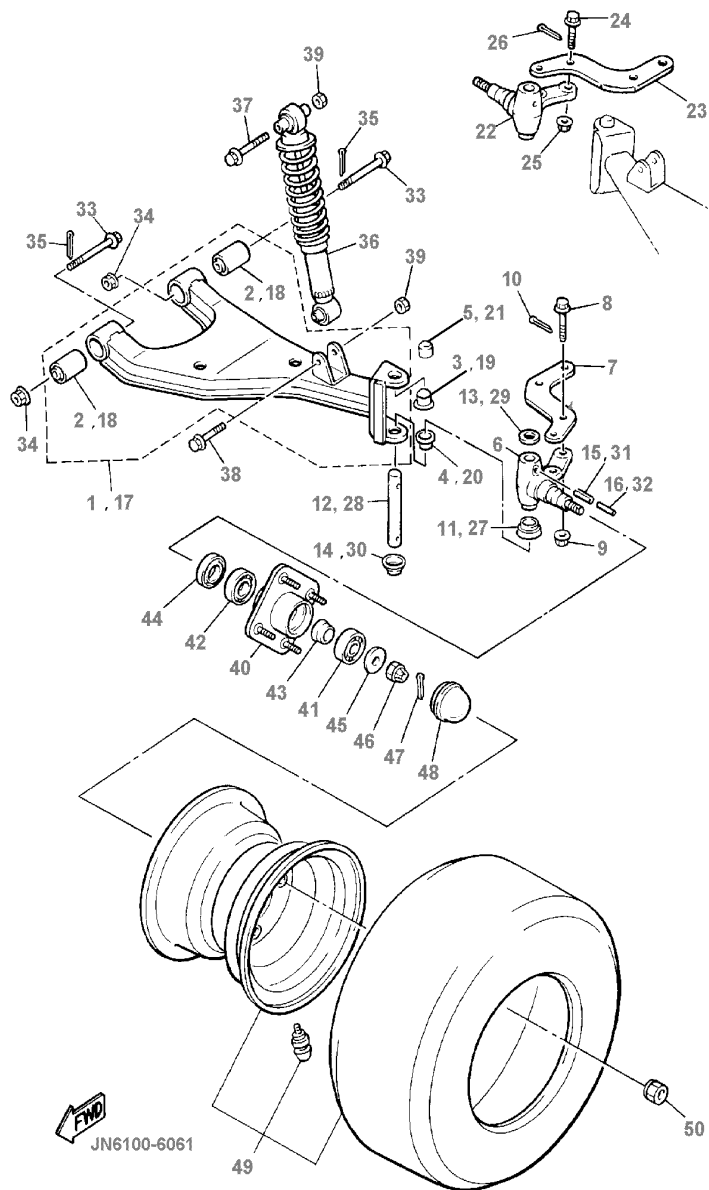
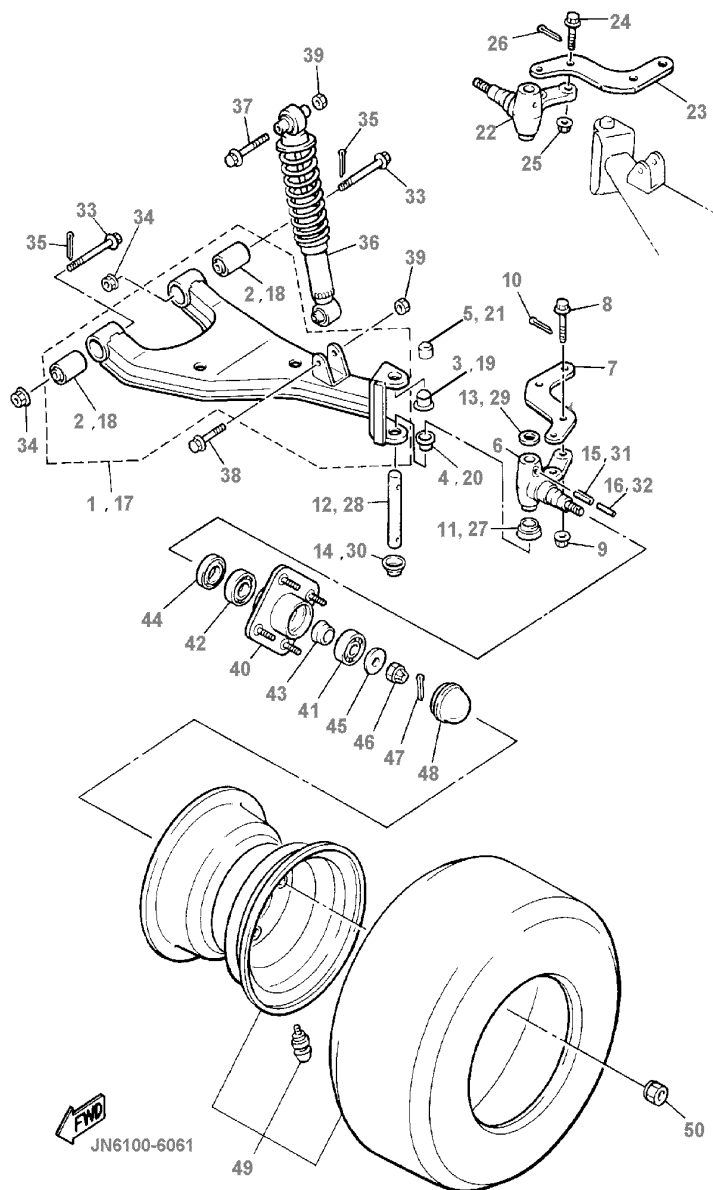

FIG. 13 FRONT SUSPENSION / WHEEL

REF NO.	PART NUMBER	DESCRIPTION	QTY	REMARKS
1	JN6-F3570-00-00	FRONT LOWER ARM, LEFT	1	
2	JN6-F3526-00-00	.BUSHING, ARM	1	
3	90384-15826-00	BUSH, BIMETAL	1	UR, F# JN6-218263-
4	90384-15825-00	BUSH, BIMETAL	1	UR, F# JN6-218263-
5	90334-19800-00	PLUG, STRAIGHT	1	UR, F# JN6-218263-
6	JN6-F3511-00-00	KNUCKLE, STEERING	1	
7	JN3-F3512-00-00	ARM, KNUCKLE	1	
8	95814-10040-00	BOLT, FLANGE	2	
9	95617-10200-00	NUT, U-FLANGE	2	
10	91490-25020-00	PIN, SPLIT	2	
11	J38-23527-00-00	SEAL, DUST 1	1	
12	J38-23516-00-00	PIN, STEERING KNUCKLE	1	
13	90201-156J2-00	WASHER, PLAIN	1	
14	J38-23528-00-00	SEAL, DUST 2	1	
15	91609-60028-00	PIN, SPRING	1	
16	91609-35028-00	PIN, SPRING	1	
17	JN6-F3580-00-00	FRONT LOWER ARM, RIGHT	1	
18	JN6-F3526-00-00	.BUSHING, ARM	1	
19	90384-15826-00	BUSH, BIMETAL	1	
20	90384-15825-00	BUSH, BIMETAL	1	
21	90334-19800-00	PLUG, STRAIGHT	1	
22	JN6-F3521-00-00	KNUCKLE, STEERING	1	
23	JN3-F3512-00-00	ARM, KNUCKLE	1	
24	95814-10040-00	BOLT, FLANGE	2	
25	95607-10200-00	NUT, U-FLANGE	2	
26	91490-25020-00	PIN, SPLIT	2	
27	J38-23527-00-00	SEAL, DUST 1	1	

FIG. 13 FRONT SUSPENSION / WHEEL



REF NO.	PART NUMBER	DESCRIPTION	QTY	REMARKS
28	J38-23516-00-00	PIN, STEERING KNUCKLE	1	
29	90201-156J2-00	WASHER, PLAIN	1	
30	J38-23528-00-00	SEAL, DUST 2	1	
31	91609-60028-00	PIN, SPRING	1	
32	91609-35028-00	PIN, SPRING	1	
33	95817-10075-00	BOLT, FLANGE	4	
34	95607-10200-00	NUT, U-FLANGE	4	
35	91490-25020-00	PIN, SPLIT	4	
36	JN3-F3350-00-00	CUSHION ASSY.	2	
37	95817-10065-00	BOLT, FLANGE	2	
38	95817-10055-00	BOLT, FLANGE	2	
39	95607-10200-00	NUT, U-FLANGE	4	
40	JG5-WF511-00-00	HUB	2	
41	93306-204X0-00	BEARING	2	
42	93306-005Y3-00	BEARING	2	
43	90387-241M7-00	COLLAR	2	
44	93102-30083-00	SEAL, OIL	2	
45	90209-32271-00	WASHER	2	
46	95607-14100-00	NUT, U	2	
47	91490-25020-00	PIN, SPLIT	2	
48	JN6-F5118-00-00	COVER, HUB DUST	2	
49	JN6-F5100-11-00	FR. WHEEL ASSY	2	
50	90179-12262-00	NUT	8	

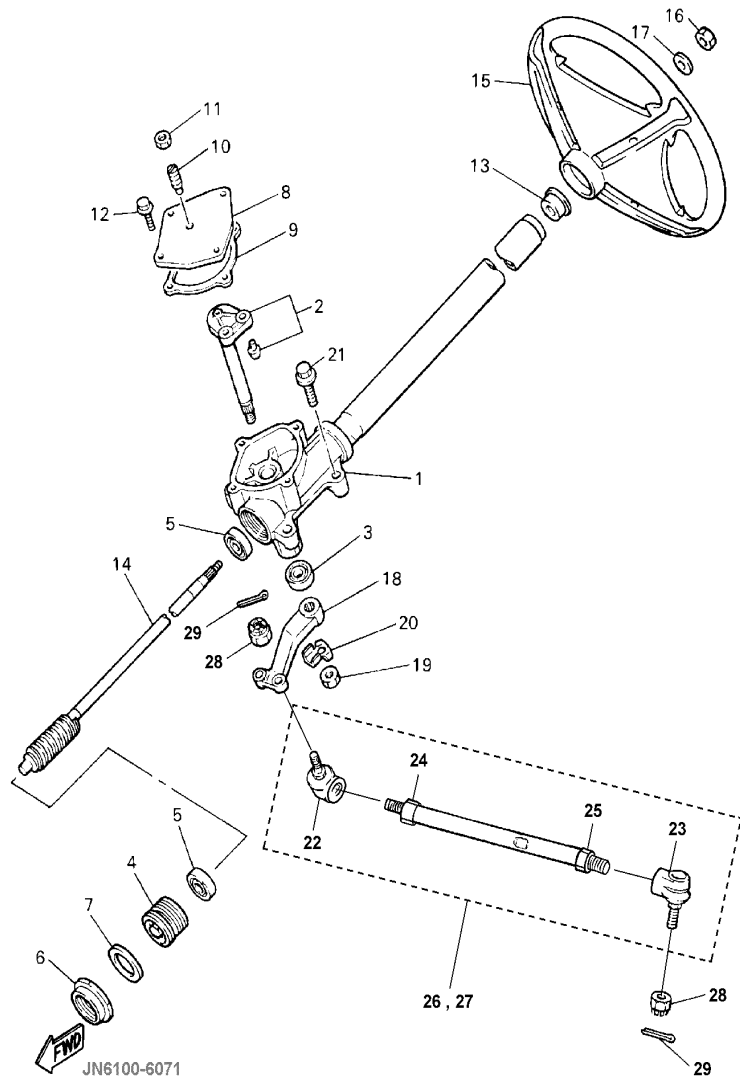

FIG. 14 STEERING

REF NO.	PART NUMBER	DESCRIPTION	QTY	REMARKS
1	JG5-F3811-00-00	COLUMN, STEERING	1	
2	J38-23816-00-00	ARM, PITMAN	1	
3	93102-22314-00	SEAL, OIL	1	
4	J55-F3876-00-00	BOLT	1	
5	93332-000Y2-00	BEARING	2	
6	J10-23877-00-00	NUT	1	
7	J10-23444-00-00	WASHER	1	
8	JN3-F3818-00-00	COVER, STEERING	1	
9	J38-23462-01-00	SEAL, STEERING	1	
10	J10-23459-00-00	BOLT	1	
11	90170-08024-00	NUT, HEX.	1	
12	95817-06020-00	BOLT, FLANGE	4	
13	JN3-F3814-00-00	HOLDER, HANDLE	1	
14	J10-23840-00-00	STEERING SHAFT	1	
15	JN3-F3838-00-00	WHEEL, STEERING	1	
16	95617-12100-00	NUT, SELF-LOCKING	1	
17	92907-12200-00	WASHER, PLAIN	1	
18	J38-23826-01-00	ARM, IDLER	1	
19	95707-16300-00	NUT, NYLON	1	
20	90215-16252-00	WASHER, TONGUE	1	
21	95817-10050-00	BOLT, FLANGE	4	
22	JN6-F3845-00-00	UNIVERSAL JOINT	2	
23	JN6-F3841-00-00	UNIVERSAL JOINT	2	
24	95607-10200-00	NUT, (RH THREAD)	2	
25	90170-12054-00	NUT, (LH THREAD)	2	
26	JN6-F3850-11-00	TIE ROD ASSY, RIGHT	1	
27	JN6-F3830-11-00	TIE ROD ASSY, LEFT	1	

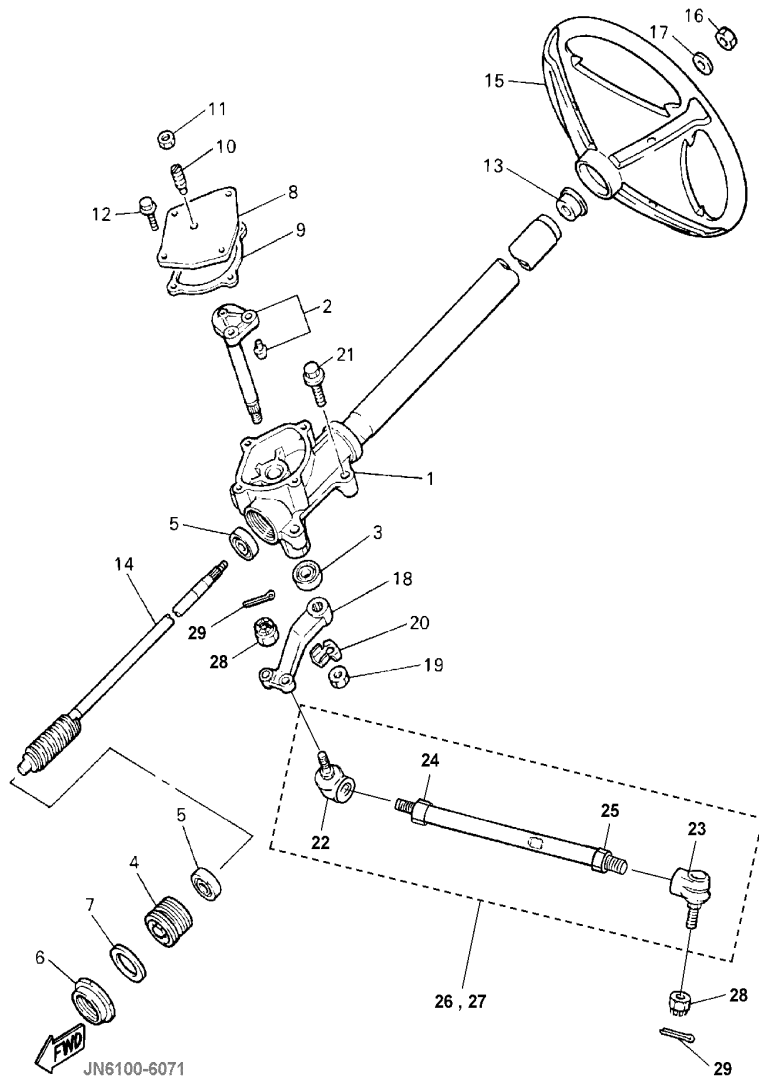
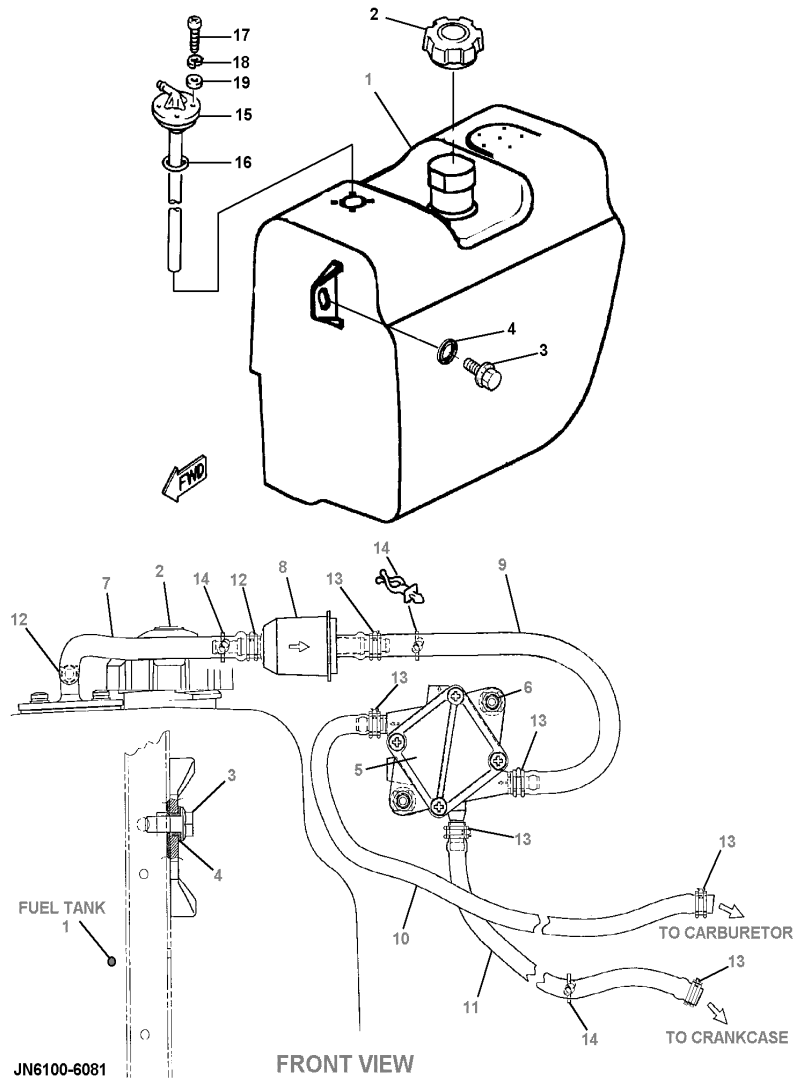

FIG. 14 STEERING

REF NO.	PART NUMBER	DESCRIPTION	QTY	REMARKS
28	95607-10200-00	NUT, U-FLANGE	4	
29	91490-25020-00	PIN, SPLIT	4	

FIG. 15 FUEL TANK



REF NO.	PART NUMBER	DESCRIPTION	QTY	REMARKS
1	JN6-F4110-01-00	FUEL TANK COMP	1	
2	JN6-F4610-00-00	CAP ASSY.	1	
3	95817-08020-00	BOLT, FLANGE	2	
4	90560-08066-00	SPACER	2	
5	JN6-F4410-00-00	FUEL PUMP ASSY	1	
6	95817-06016-00	BOLT, FLANGE	2	
7	JN6-F4312-00-00	PIPE, 2	1	
8	JN6-F4560-00-00	FILTER ASSY.	1	
9	JN6-F4311-00-00	PIPE, FUEL	1	
10	JN6-F4313-00-00	PIPE, 3	1	
11	JN6-F4314-00-00	PIPE, 4	1	
12	90467-12845-00	CLIP	2	RED
13	90467-10846-00	CLIP	6	GREEN
14	90464-11816-00	CLAMP	3	
15	JN3-F4300-02-00	.FUEL PIPE JOINT	1	
16	93210-228C4-00	.O-RING	1	
17	98507-05014-00	.SCREW, PAN HEAD	4	
18	92907-05100-00	.WASHER, LOCK	4	
19	92907-05600-00	.WASHER, PLAIN	4	

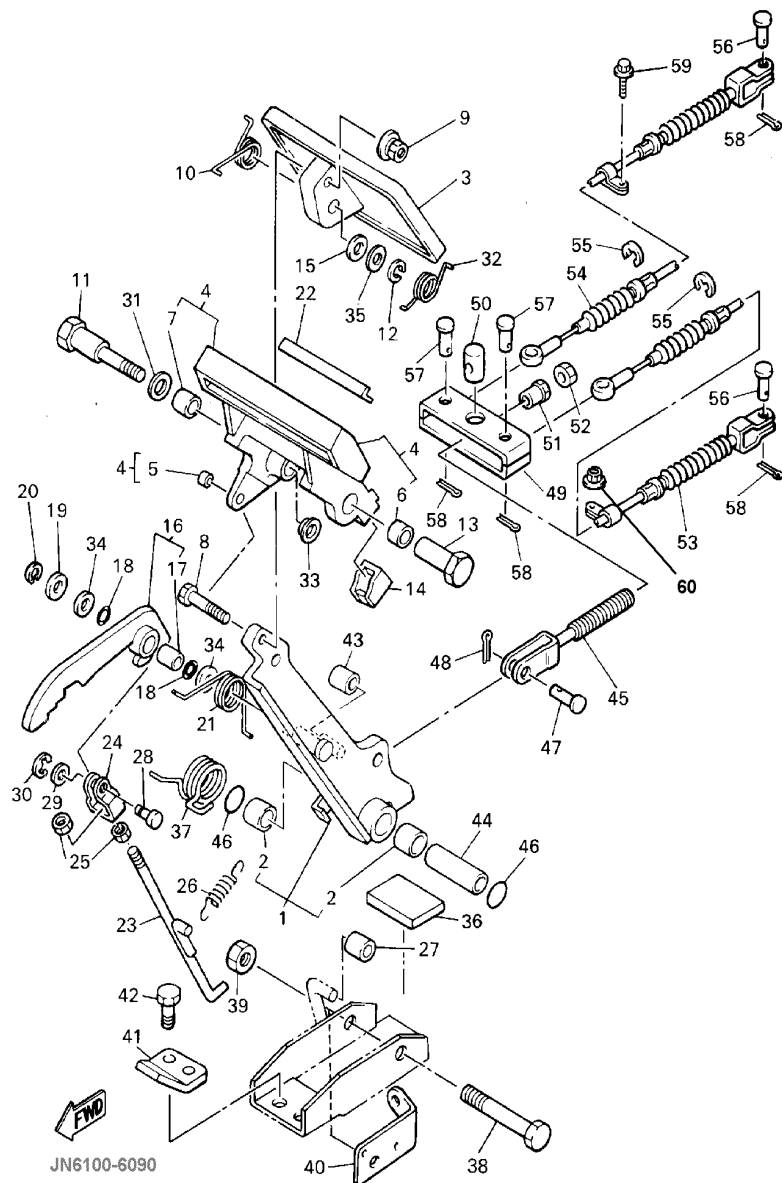

JN6100-6090

FIG. 16 BRAKE

REF NO.	PART NUMBER	DESCRIPTION	QTY	REMARKS
1	J46-27250-03-00	BRAKE ARM COMP	1	
2	90384-14080-00	.BUSH, BIMETAL FORMED	2	
3	J10-27211-00-00	PEDAL, BRAKE	1	
4	J17-25670-01-00	PARKING PEDAL COMP.	1	
5	90384-05163-00	.BUSH, BIMETAL	1	
6	90384-12164-00	.BUSH, BIMETAL	1	
7	90380-12051-00	.BUSH, SOLID	1	
8	90101-06555-00	BOLT, HEX.	1	
9	90179-06387-00	NUT	1	
10	90508-23542-00	SPRING, TORSION	1	
11	90109-08669-00	BOLT	1	
12	92907-08100-00	WASHER, SPRING	1	
13	90179-08378-00	NUT	1	
14	J17-25679-01-00	DAMPER	2	
15	92907-08200-00	WASHER, PLAIN	1	
16	J17-W2561-02-00	SECTOR, PARKING BRAKE	1	
17	90384-10162-00	.BUSH, BIMETAL	1	
18	J17-27221-00-00	SEAL, SHAFT	2	
19	92907-10600-00	WASHER, PLAIN	1	
20	99080-07600-00	CIRCLIP (E)	1	
21	90508-14548-00	SPRING, TORSION	1	
22	J17-25672-01-00	PAD, PARKING	1	
23	J17-27231-03-00	ROD, BRAKE	1	
24	J17-27232-00-00	END, ROD 1	1	
25	95317-06700-00	NUT, HEX.	2	
26	90506-08526-00	SPRING, TENSION	1	
27	J17-25673-00-00	DAMPER, BRAKE	1	

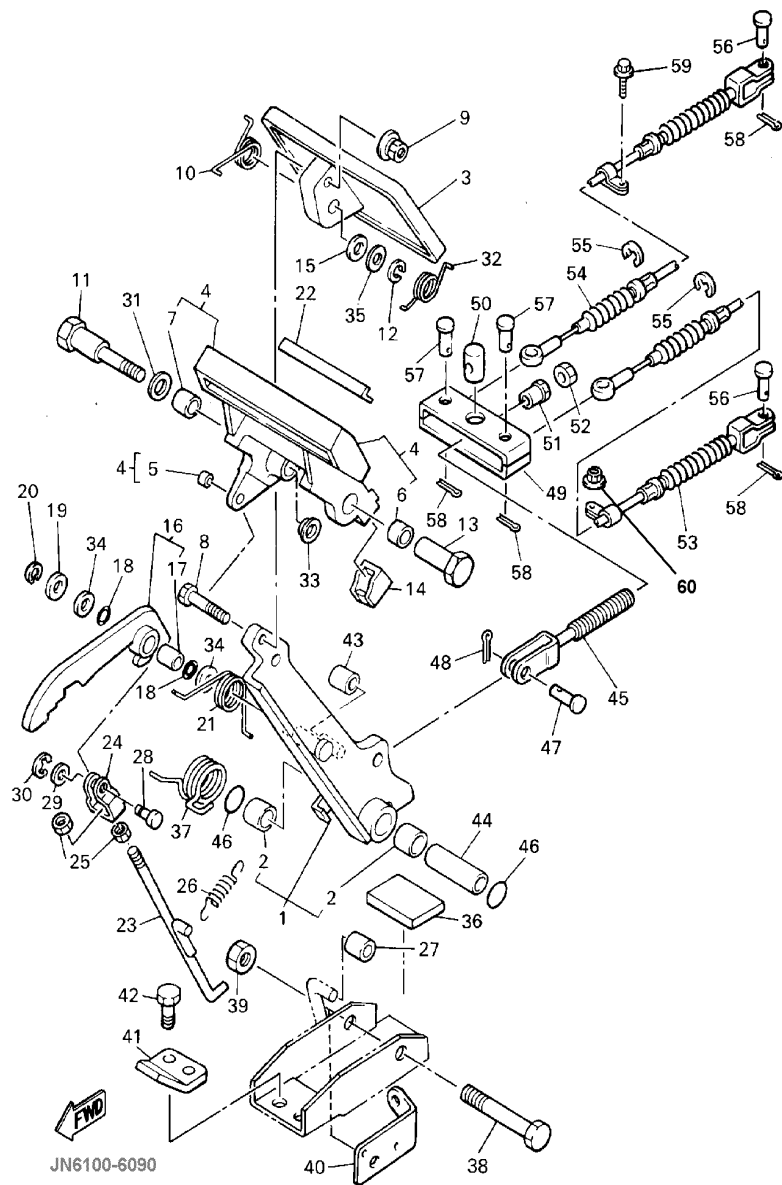
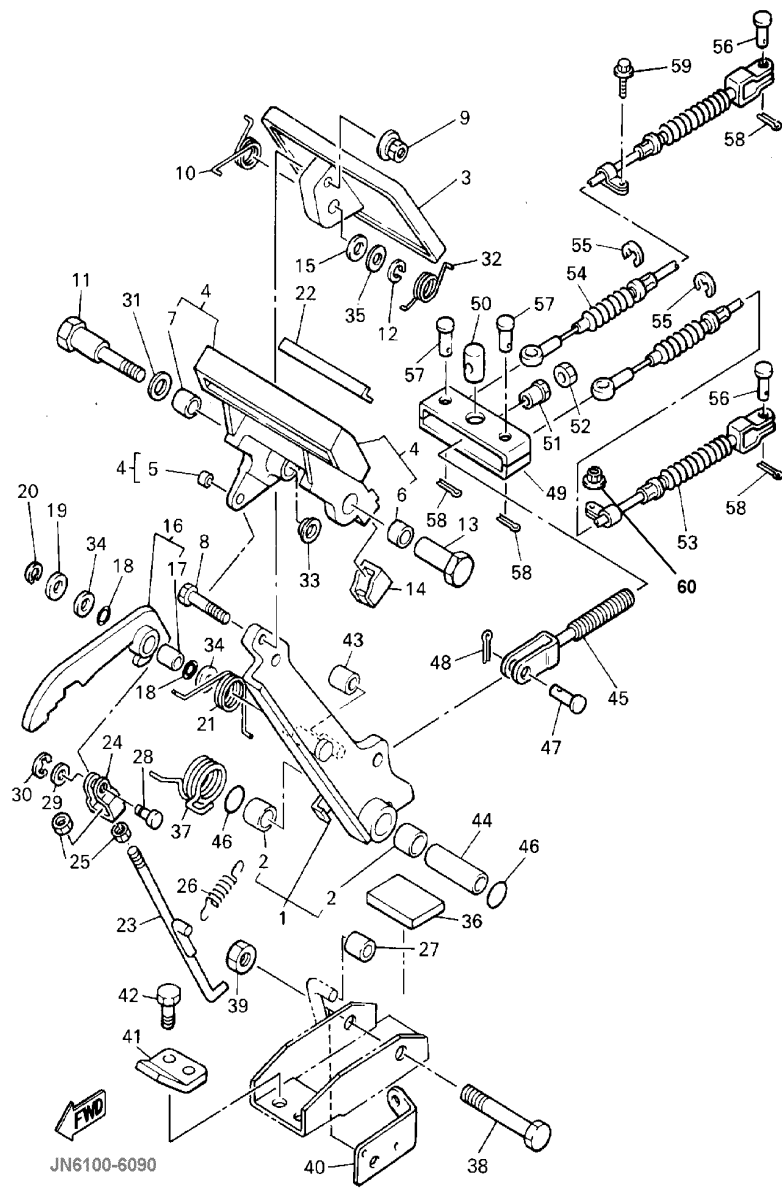

FIG. 16 BRAKE

REF NO.	PART NUMBER	DESCRIPTION	QTY	REMARKS
28	J17-27228-00-00	PIN, LINK JOINT	1	
29	92907-05600-00	WASHER, PLAIN	1	
30	99080-04600-00	CIRCLIP (E)	1	
31	90201-123F2-00	WASHER, PLAIN	1	
32	90508-26557-00	SPRING, TORSION	1	
33	90380-12105-00	BUSH, SOLID	1	
34	90201-104G8-00	WASHER, PLAIN	2	
35	J55-27226-00-00	WASHER, LINK	1	
36	JN3-F7245-00-00	PAD, BRAKE PEDAL	1	
37	90508-405A9-00	SPRING, TORSION	1	
38	90101-10447-00	BOLT, HEX.	1	
39	95617-10200-00	NUT, U-FLANGE	1	
40	J55-2252M-00-00	BRACKET, 3	1	
41	J17-27246-00-00	NAIL, BRAKE	1	
42	95817-08020-00	BOLT, FLANGE	2	
43	J17-25673-00-00	DAMPER, BRAKE	1	
44	90387-107F8-00	COLLAR	1	
45	JN6-F5685-00-00	ROD	1	
46	93210-132A8-00	O-RING	2	
47	91701-10022-00	PIN	1	
48	91490-30020-00	PIN, SPLIT	1	
49	JN6-F5681-00-00	EQUALIZER, BRAKE	1	
50	90249-14129-00	PIN	1	
51	90179-08261-00	NUT	1	
52	95317-08700-00	NUT, HEX.	1	
53	JN6-F6341-00-00	WIRE, BRAKE 1	1	
54	JF2-F6351-10-00	WIRE, BRAKE 2	1	

FIG. 16 BRAKE



JN6100-6090

REF NO.	PART NUMBER	DESCRIPTION	QTY	REMARKS
55	99001-09600-00	CIRCLIP (E)	4	
56	91701-08018-00	PIN	2	
57	91701-08026-00	PIN	2	
58	91490-25020-00	PIN,SPLIT	4	
59	95817-06016-00	BOLT, FLANGE	2	
60	95617-08200-00	NUT, U-FLANGE	1	

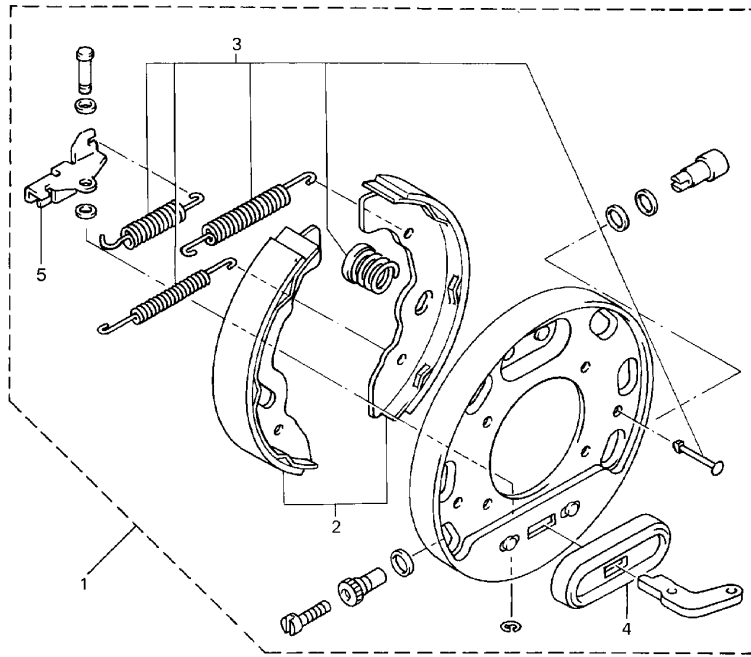
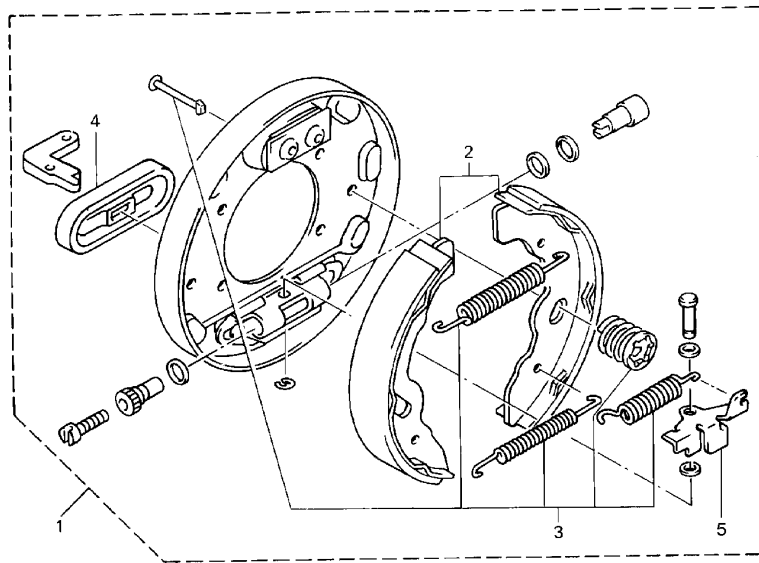

FIG. 17 BRAKE 2

REF NO.	PART NUMBER	DESCRIPTION	QTY	REMARKS
1	JN6-F7280-00-00	BACKING PLATE, (RH)	1	(FOR RIGHT WHEEL ONLY)
2	JN3-F5340-00-00	.SHOE, BRAKE SET	1	(FOR ONE WHEEL)
3	JG5-F819G-00-00	.REPAIR PARTS KIT	1	
4	JG5-F7286-00-00	.COVER, DUST	1	
5	JN6-F722F-00-00	.LEVER ADJUSTER (RH)	1	

 JN4100-5061

FIG. 18 BRAKE 3



REF NO.	PART NUMBER	DESCRIPTION	QTY	REMARKS
1	JN6-F7290-00-00	BACKING PLATE, (LH)	1	(FOR LEFT WHEEL ONLY)
2	JN3-F5330-00-00	.SHOE, BRAKE SET	1	(FOR ONE WHEEL)
3	JG5-F819G-00-00	.REPAIR PARTS KIT	1	
4	JG5-F7286-00-00	.COVER, DUST	1	
5	JN6-F722E-00-00	.LEVER ADJUSTER (LH)	1	



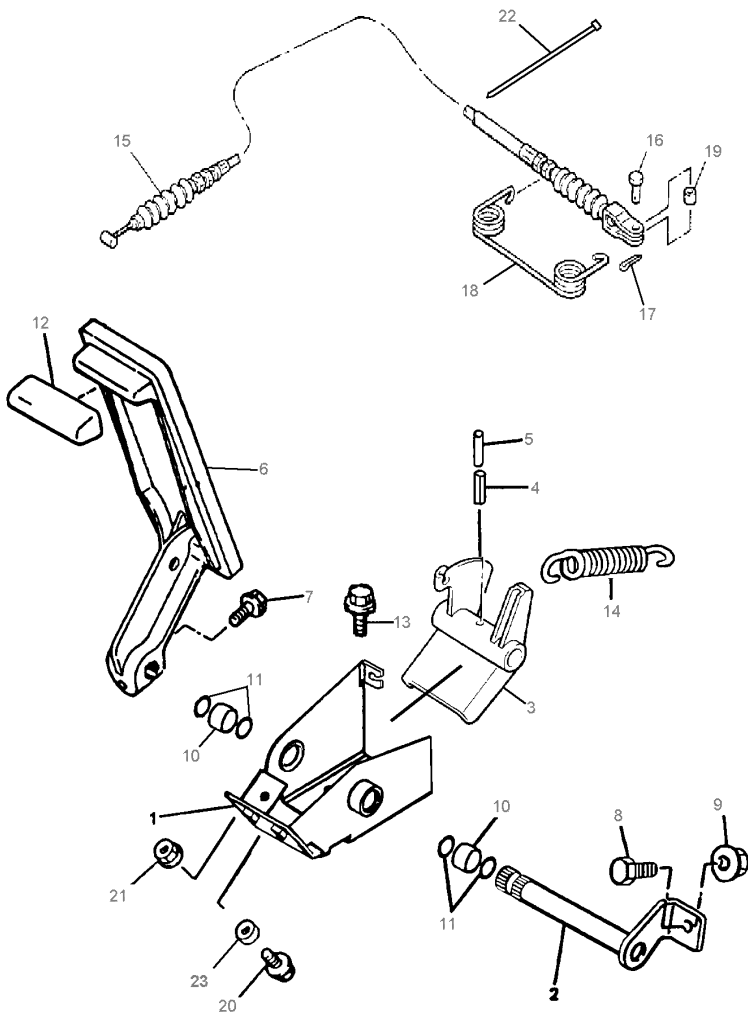

FWD
JN6200-7020

FIG. 19 ACCELERATOR

REF NO.	PART NUMBER	DESCRIPTION	QTY	REMARKS
1	JN6-F7874-01-00	BRACKET, PEDAL	1	
2	J17-27853-01-00	SHAFT, PEDAL	1	
3	J38-27872-00-00	ARM, ACCELERATOR	1	
4	91609-60028-00	PIN, SPRING	1	
5	91609-35028-00	PIN, SPRING	1	
6	JF3-27871-00-00	PEDAL, ACCELERATOR	1	
7	95817-06025-00	BOLT, FLANGE	1	
8	90106-08040-00	BOLT, RD. HEX	1	
9	95707-08500-00	NUT, FLANGE	1	
10	90384-14080-00	BUSH, BIMETAL	2	
11	93210-14104-00	O-RING	4	
12	JN3-F7854-00-00	COVER, PEDAL	1	
13	95817-08016-00	BOLT, HEX. H	3	
14	90506-26282-00	SPRING, TENSION	1	
15	JN3-F6311-00-00	WIRE, THROTTLE	1	
16	91790-05012-00	PIN	1	
17	90468-10050-00	CLIP	1	
18	90508-16460-00	SPRING, TORSION	1	
19	90560-05001-00	SPACER	1	
20	95817-06025-00	BOLT, FLANGE	1	
21	95707-06500-00	NUT, FLANGE	1	
22	90601-200U1-00	BAND	1	
23	90387-068T4-00	COLLAR	1	

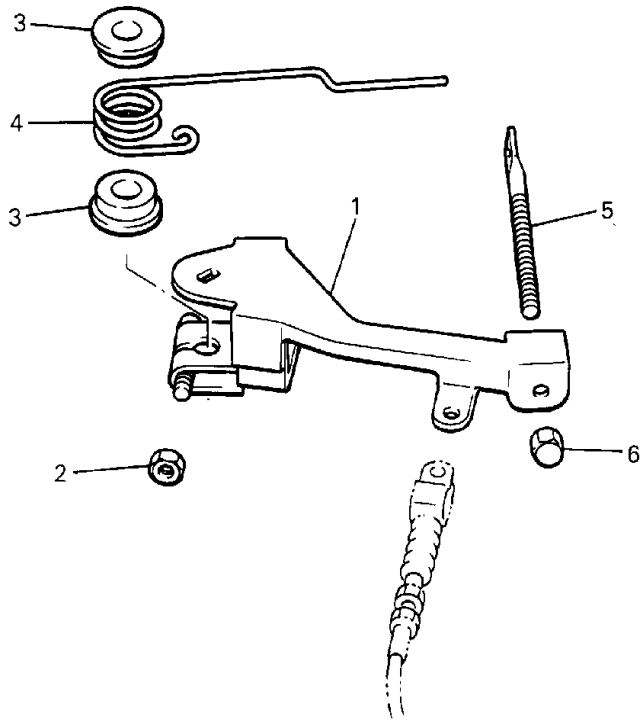

JN6100-6131

FIG. 20 GOVERNOR

REF NO.	PART NUMBER	DESCRIPTION	QTY	REMARKS
1	J38-27951-00-00	LEVER, SPEED	1	
2	95317-06600-00	NUT, HEX.	1	
3	90386-08141-00	BUSH	2	
4	90508-40678-00	SPRING, TORSION	1	
5	J38-27959-00-00	SCREW, ADJUSTING	1	
6	95607-06200-00	NUT, U-FLANGE	1	
7	JN3-G6555-00-00	BRACKET 2	1	
8	90105-08859-00	BOLT, FLANGE	1	

FIG. 21 PRIMARY CLUTCH

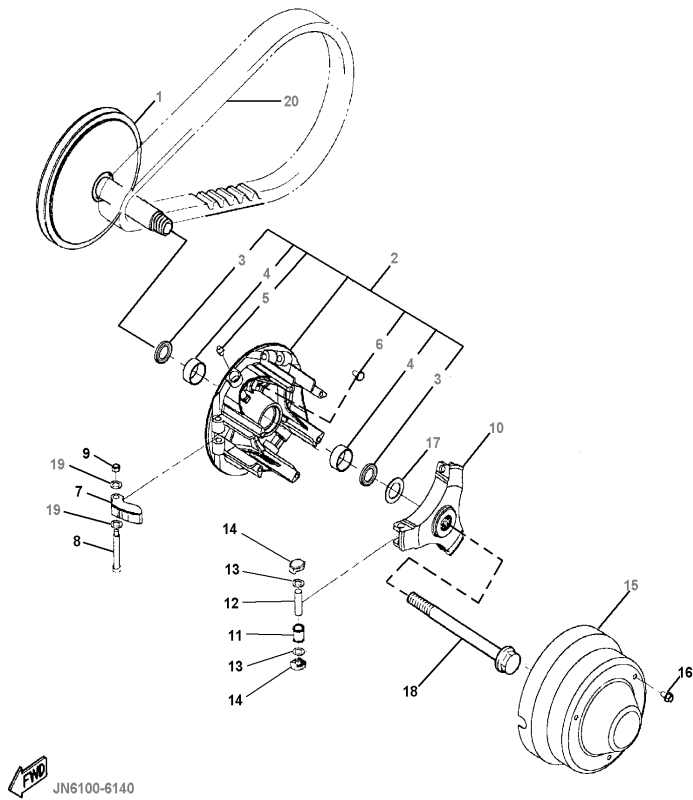

REF NO.	PART NUMBER	DESCRIPTION	QTY	REMARKS
	JN6-G6201-00-00	PRIMARY CLUTCH ASSEMBLY	1	SEE NOTE "A"
1	JN6-G6210-00-00	PRIMARY FIXED SHEAVE	1	
2	JN6-G6220-00-00	PRIMARY SLIDING SHEAVE	1	
3	93101-28831-00	.SEAL, OIL	2	
4	90384-27823-00	.BUSH, BIMETAL	2	
5	93700-06810-00	.NIPPLE, GREASE	1	
6	90338-04840-00	.PLUG	3	
7	JN6-G6232-00-00	WEIGHT, 1	3	
8	90109-06860-00	BOLT	3	
9	90185-06834-00	NUT, SELF-LOCKING	3	
10	JN6-G6251-00-00	SPIDER	1	
11	JN6-G6258-01-00	COLLAR, ROLLER	3	
12	93610-358A3-00	PIN, DOWEL	3	
13	90201-098J1-00	WASHER, PLAIN	6	
14	JN6-G6253-00-00	SLIDER	6	
15	JN6-G6231-00-00	CAP	1	
16	90105-06861-00	BOLT, FLANGE	3	
17	90201-228K5-00	WASHER, PLAIN	1	
18	JN6-G6249-00-00	BOLT	1	
19	JN6-G621F-00-00	SHIM, THRUST	6	
20	J55-G6241-00-00	BELT	1	

NOTE "A": Assembly includes all parts except REF. Numbers 15, 16, 18 and 20 (the cap, 3 flange bolts for cap and the main bolt for the Primary Clutch assembly).

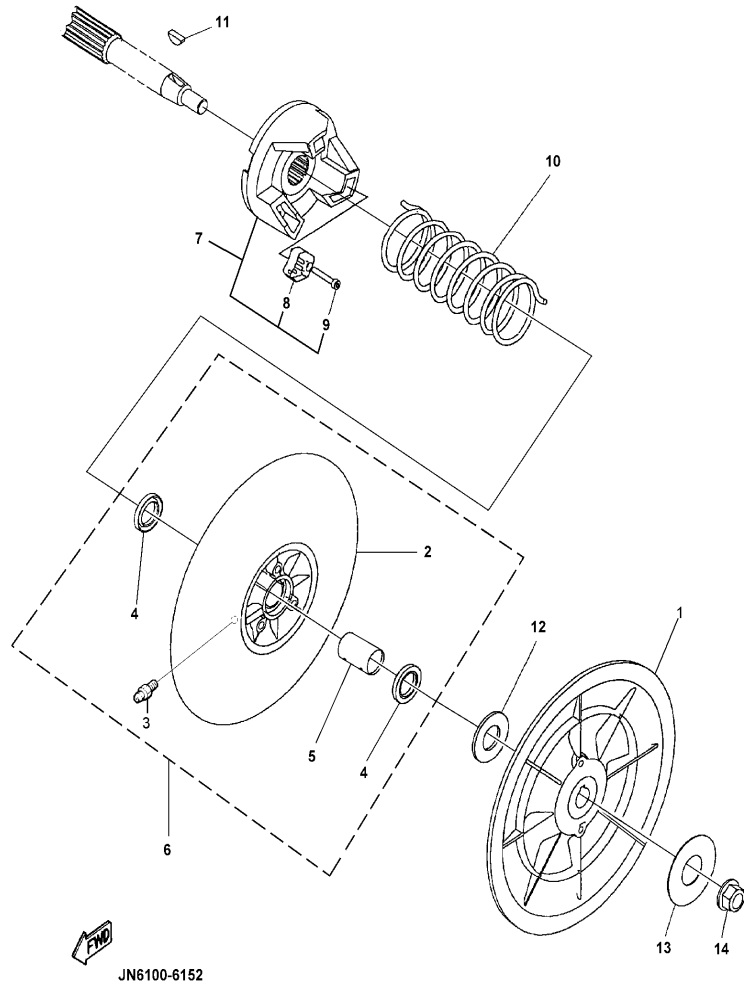
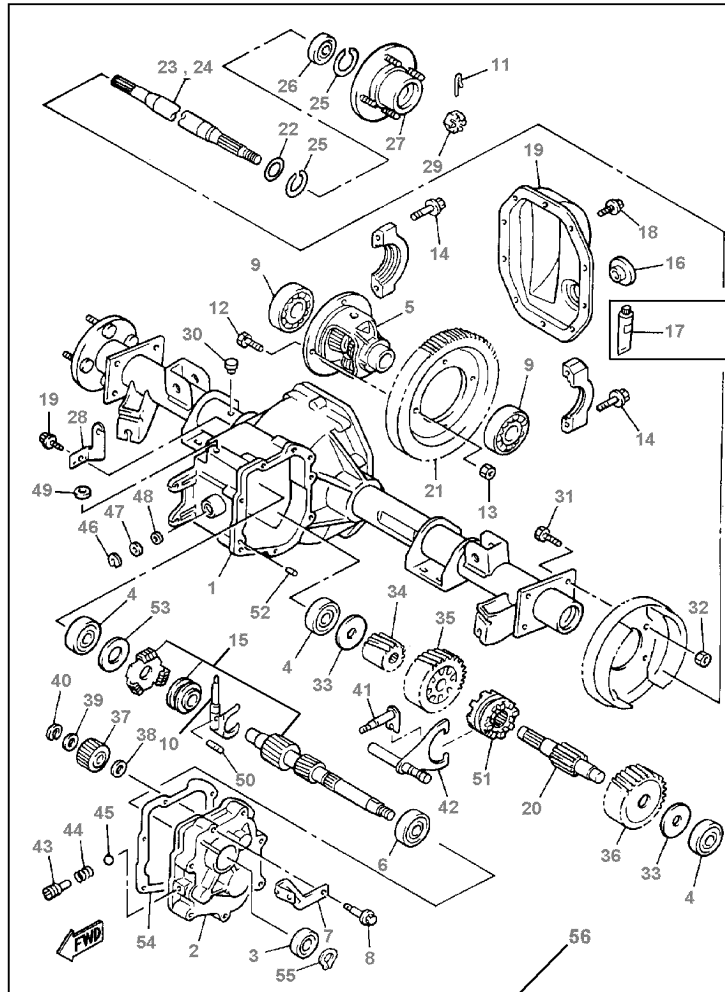

FIG. 22 SECONDARY SHEAVE

REF NO.	PART NUMBER	DESCRIPTION	QTY	REMARKS
1	JN6-G6260-00-00	SECONDARY FIXED SHEAVE	1	
2	JN6-G6271-02-00	SECONDARY SLIDING SHEAVE	1	
3	93700-06809-00	.NIPPLE, GREASE	1	
4	93109-20069-00	.SEAL, OIL	2	
5	90384-20143-00	BUSHING	1	
6	JN6-G6270-01-KT	SECONDARY SLIDING SHEAVE KIT	1	SEE NOTE "A"
7	JN6-G6280-00-00	SECONDARY SPRING SEAT	1	
8	JN6-E7688-00-00	.SHOE, RAMP	3	
9	90110-04834-00	.BOLT, HEX. SOCKET	3	
10	90508-45844-00	SPRING, TORSION	1	L=100.5mm±1.5
11	90202-20130-00	WASHER, PLAIN	1	
12	90280-05022-00	KEY, WOODRUFF	1	
13	90201-12588-00	WASHER, PLAIN	1	
14	95617-12200-00	NUT, U-FLANGE	1	

NOTE "A": Secondary sheave kit includes oil seals, bushing, and grease nipple.



JR2010-6222

FIG. 23 TRANSMISSION 1

REF NO.	PART NUMBER	DESCRIPTION	QTY	REMARKS
1	JN3-G6290-00-00	CASE ASSY	1	
2	JN3-G6313-00-00	COVER, TRANSMISSION	1	
3	93102-25868-00	SEAL, OIL	1	
4	93306-303Y6-00	BEARING	3	
5	JN6-G6410-00-00	DIFFERENTIAL ASSY.	1	
6	93306-005Y4-00	BEARING	1	
7	JN6-G6555-00-00	BRACKET, 2	1	
8	90105-08859-00	BOLT, FLANGE	7	
9	93306-007Y0-00	BEARING	2	
10	JN3-G633E-00-00	BAR, 1	1	
11	91490-25030-00	PIN, SPLIT	2	
12	90101-10854-00	BOLT, HEX.	4	
13	90170-10840-00	NUT, HEX.	4	
14	90105-10840-00	BOLT, FLANGE	4	
15	JN3-G6320-00-00	SHAFT, INPUT ASSY.	1	
16	JN3-G6432-00-00	STOPPER	1	
17	ACC-QUICK-GS-KT	SEALANT 1	1	
18	90101-08856-00	BOLT, HEX.	11	
19	JN3-G6314-00-00	COVER, TRANSMISSION	1	
20	JN3-G633G-00-00	SHAFT	1	
21	JN3-G6355-00-00	GEAR, PRIMARY	1	
22	93101-24822-00	SEAL, OIL	2	
23	JN3-G6511-00-00	SHAFT, RR. AXLE	1	
24	JN3-G6512-00-00	SHAFT, RR. AXLE	1	
25	93420-44805-00	CIRCLIP	4	
26	93306-004X5-00	BEARING	2	
27	JN3-G6514-00-00	HUB, RR. AXLE	2	

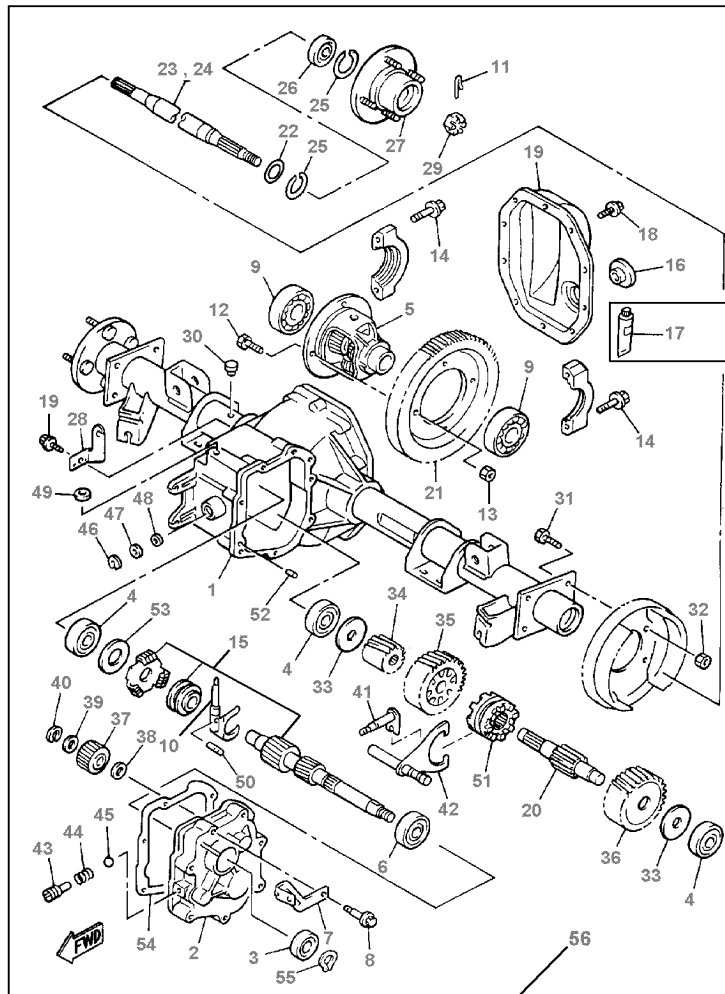

JR2010-6222

FIG. 23 TRANSMISSION 1

REF NO.	PART NUMBER	DESCRIPTION	QTY	REMARKS
28	JN3-G6556-00-00	BRACKET, 3	1	
29	90185-16833-00	NUT, SELF-LOCKING	2	
30	JH7-G5619-00-00	CAP	1	
31	90101-08855-00	BOLT, HEX.	8	
32	90170-08841-00	NUT, HEX.	8	
33	90201-178H8-00	WASHER, PLAIN	2	
34	JN3-G6316-00-00	GEAR, PINION	1	
35	JN3-G6326-00-00	GEAR, WHEEL 1	1	
36	JN3-G6327-00-00	GEAR, WHEEL 2	1	
37	JN3-G6356-00-00	GEAR, IDLER	1	
38	90201-208H9-00	WASHER, PLAIN	1	
39	90201-208J0-00	WASHER, PLAIN	1	
40	93440-20813-00	CIRCLIP	1	
41	JN3-G638A-00-00	BAR, SHIFT 1	1	
42	JN6-G638E-00-00	BAR, SHIFT 2	1	
43	90113-08803-00	BOLT, SET	1	
44	90501-10852-00	SPRING, COMPRESSION	1	
45	93500-06826-00	BALL	1	
46	93410-12822-00	CIRCLIP	1	
47	90202-12807-00	WASHER, PLAIN	1	
48	93104-11829-00	SEAL, OIL	1	
49	93109-10820-00	SEAL, OIL	1	
50	JN3-G6249-00-00	BOLT	1	
51	JN3-G6153-00-00	COLLAR, GUIDE	1	
52	93606-10842-00	PIN, DOWEL	2	
53	JN3-G6344-00-00	SHIM	1	0.76mm (0.030in)
	JN3-G6344-10-00	SHIM	1	0.90mm (0.035in)

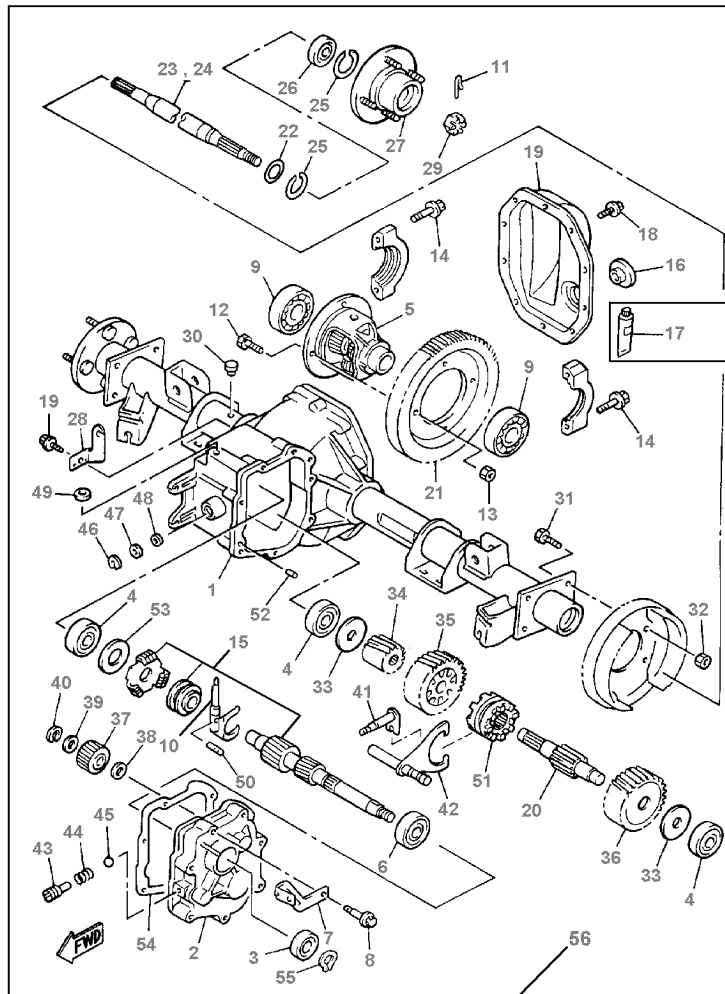

JR2010-6222

FIG. 23 TRANSMISSION 1

REF NO.	PART NUMBER	DESCRIPTION	QTY	REMARKS
	JN3-G6344-20-00	SHIM	1	1.0mm (0.040in)
	JN3-G6344-30-00	SHIM	1	1.14mm (0.045in)
	JN3-G6344-40-00	SHIM	1	1.27mm (0.050in)
	JN3-G6344-50-00	SHIM	1	1.39mm (0.055in)
	JN3-G6344-60-00	SHIM	1	1.52mm (0.060in)
	JN3-G6344-70-00	SHIM	1	1.65mm (0.065in)
	JN3-G6344-80-00	SHIM	1	0.38mm (0.015in)
54	JN3-G6319-00-00	GASKET	1	
55	93410-25017-00	CIRCLIP (S)	1	
56	JN6-G6300-01-00	TRANSAXLE ASSEMBLY	1	With brake plates

FIG. 24 REAR AXLE MOUNT / WHEEL

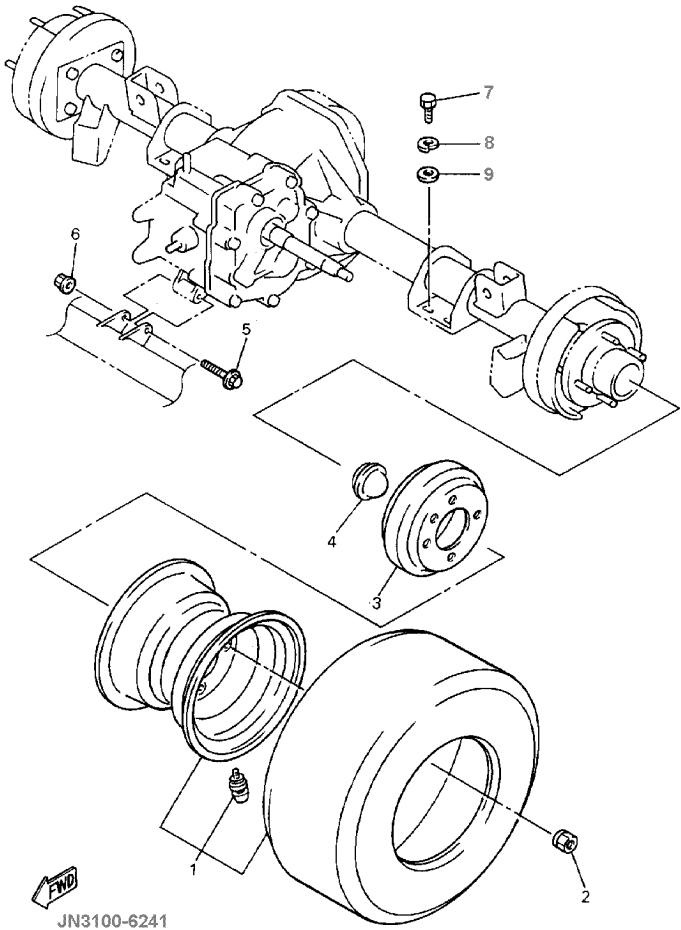

REF NO.	PART NUMBER	DESCRIPTION	QTY	REMARKS
1	JN6-F5100-11-00	WHEEL ASSY.	2	
2	90179-12262-00	NUT	8	
3	J55-G6521-00-00	DRUM	2	
4	JN6-F5118-00-00	COVER, HUB DUST	2	
5	95817-08075-00	BOLT, FLANGE	1	
6	95707-08500-00	NUT, FLANGE	1	
7	97017-10020-00	BOLT	8	
8	92907-10100-00	WASHER, LOCK	8	
9	90201-102G9-00	WASHER	8	

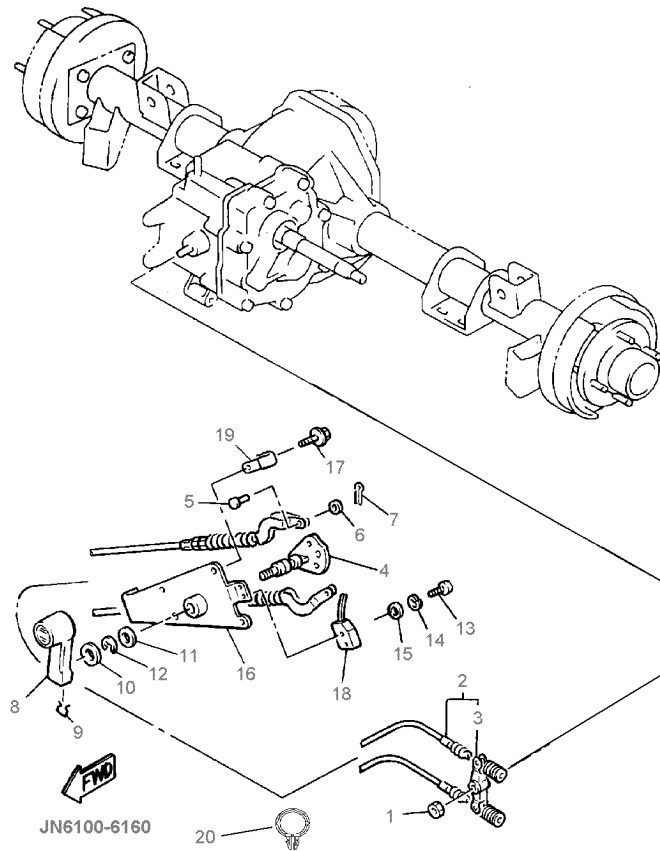
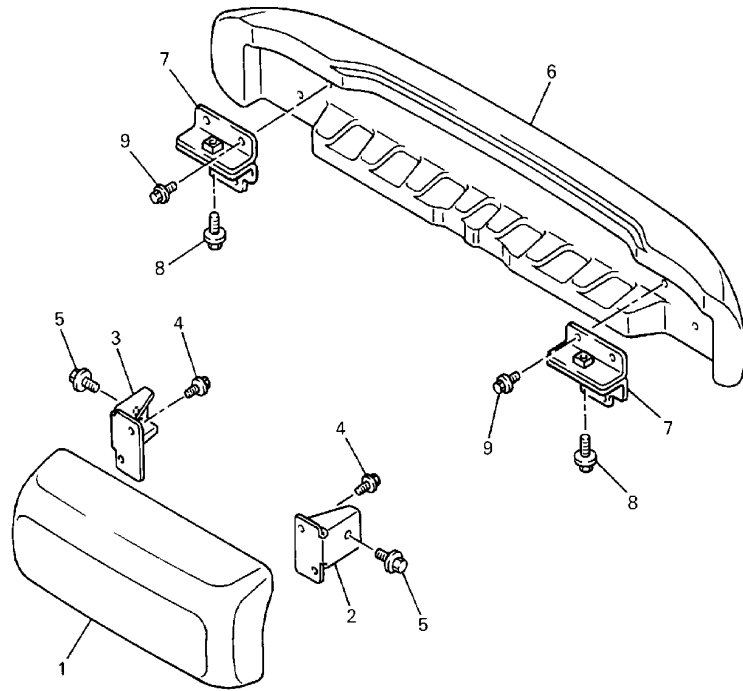

FIG. 25 SHIFTER / CABLES

REF NO.	PART NUMBER	DESCRIPTION	QTY	REMARKS
1	95617-08100-00	NUT, U	1	
2	JN3-G8330-00-00	CABLE, SHIFT	2	
3	J55-G6383-00-00	LEVER, SHIFT 2	1	
4	JF2-46382-00-00	LEVER, SHIFT 1	1	
5	91702-06014-00	PIN	2	
6	92907-06600-00	WASHER, PLAIN	2	
7	91490-20025-00	PIN, SPLIT	2	
8	JN3-G6381-00-00	KNOB, SHIFT	1	
9	JN3-G6376-00-00	SPRING SET	1	
10	90201-201L9-00	WASHER, PLAIN	1	
11	90201-19551-00	WASHER, PLAIN	1	
12	99009-19400-00	CIRCLIP (S)	1	
13	98507-04016-00	SCREW, PANHEAD	2	
14	92907-04100-00	WASHER, LOCK	2	
15	92907-04600-00	WASHER	2	
16	JN3-G6372-00-00	BRACKET, SHIFT	1	
17	95817-06016-00	BOLT, FLANGE	4	
18	JN3-82617-00-00	SWITCH	1	
19	90465-06038-00	CLAMP	1	
20	90464-19815-00	CLAMP	1	

FIG. 26 BUMPER



REF NO.	PART NUMBER	DESCRIPTION	QTY	REMARKS
1	JN3-K7510-02-00	FRONT BUMPER COMP.	1	
2	JN3-K8164-00-00	STAY, FR. BUMPER	1	
3	JN3-K8165-00-00	STAY, FR. BUMPER	1	
4	95817-06016-00	BOLT, FLANGE	4	
5	95817-08016-00	BOLT, FLANGE	2	
6	JN6-K7540-00-00	REAR BUMPER	1	
7	JN3-K8174-00-00	STAY, RR. BUMPER	2	
8	95817-10020-00	BOLT, FLANGE	2	
9	95817-06016-00	BOLT, FLANGE	4	

 JN6100-6170

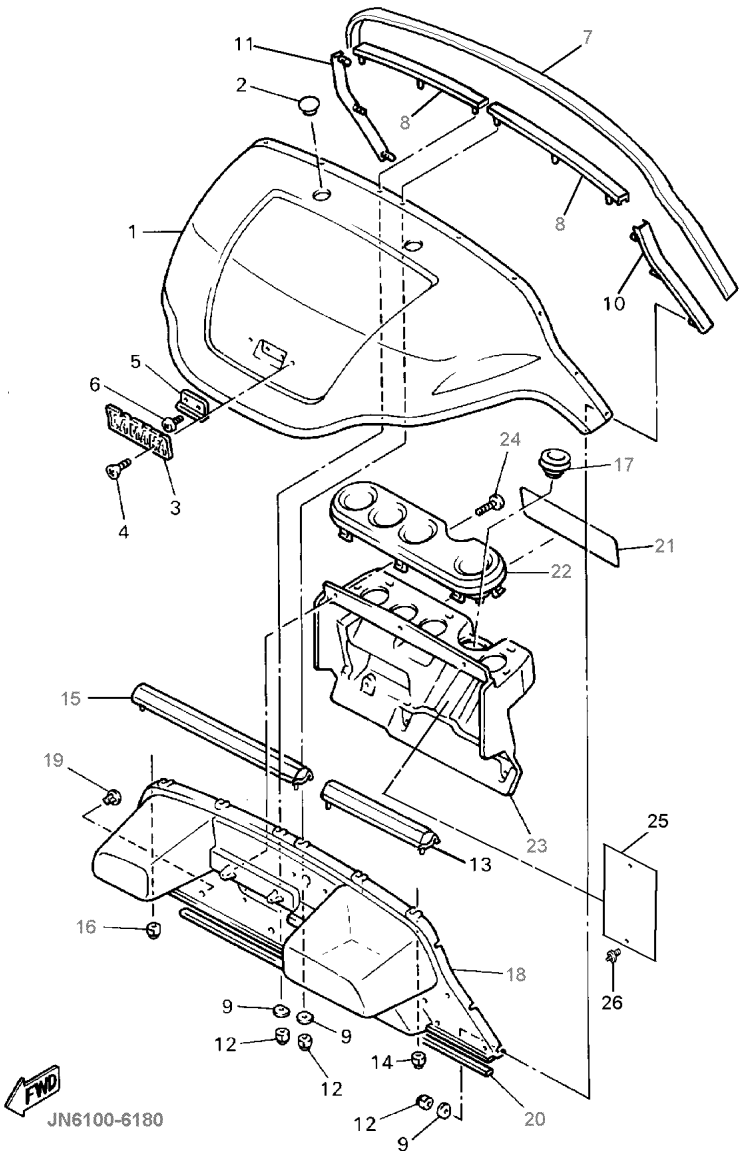

FIG. 27 BODY

REF NO.	PART NUMBER	DESCRIPTION	QTY	REMARKS
1	JN3-K8115-00-00	COWL, FRONT	1	IVORY
	JN3-K8115-10-00	COWL, FRONT	1	RED
	JN3-K8115-30-00	COWL, FRONT	1	TEAL
	JN3-K8115-50-00	COWL, FRONT	1	HUNTER GRN
2	JN3-K818E-00-00	CAP, PROTECTOR	2	W/O SUNTOP
3	JN6-F4161-01-00	EMBLEM, 1	1	
4	90162-04002-00	SCREW, OVAL C	2	
5	JF2-K811G-00-00	BOLT, COWL FITTING	1	
6	98980-06016-00	SCREW, BINDING	2	
7	JF2-K811V-00-00	PROTECTOR, 1	1	
8	JF2-K8261-02-00	PLATE, BODY PROTECTOR	2	
9	JN3-K8117-00-00	PLATE, 1	12	
10	JF2-K8262-01-00	PLATE, BODY PROTECTOR	1	
11	JF2-K8263-01-00	PLATE, BODY PROTECTOR	1	
12	90185-06836-00	NUT, SELF-LOCKING	12	
13	JN6-K8264-00-00	PLATE, BODY PROTECTOR	1	
14	95607-06200-00	NUT, U-FLANGE	2	
15	JN6-K8265-00-00	PLATE, BODY PROTECTOR	1	
16	95607-06200-00	NUT, U-FLANGE	2	
17	JN3-K8273-00-00	COVER, HOLE 1	1	
18	JF2-K8114-02-00	PANEL, FRONT	1	
19	90269-08069-00	RIVET	3	
20	JN3-K815G-00-00	SEAL, FRONT STORAGE	1	
21	JN3-K7768-00-00	LABEL, WARNING 8	1	UR, FOR USA SEE NOTE "A"
	JN3-K7768-10-00	LABEL, WARNING 8	1	UR, FOR CAN SEE NOTE "A"
	JN3-K7768-20-00	LABEL, WARNING 8	1	UR, FOR EUR SEE NOTE "A"

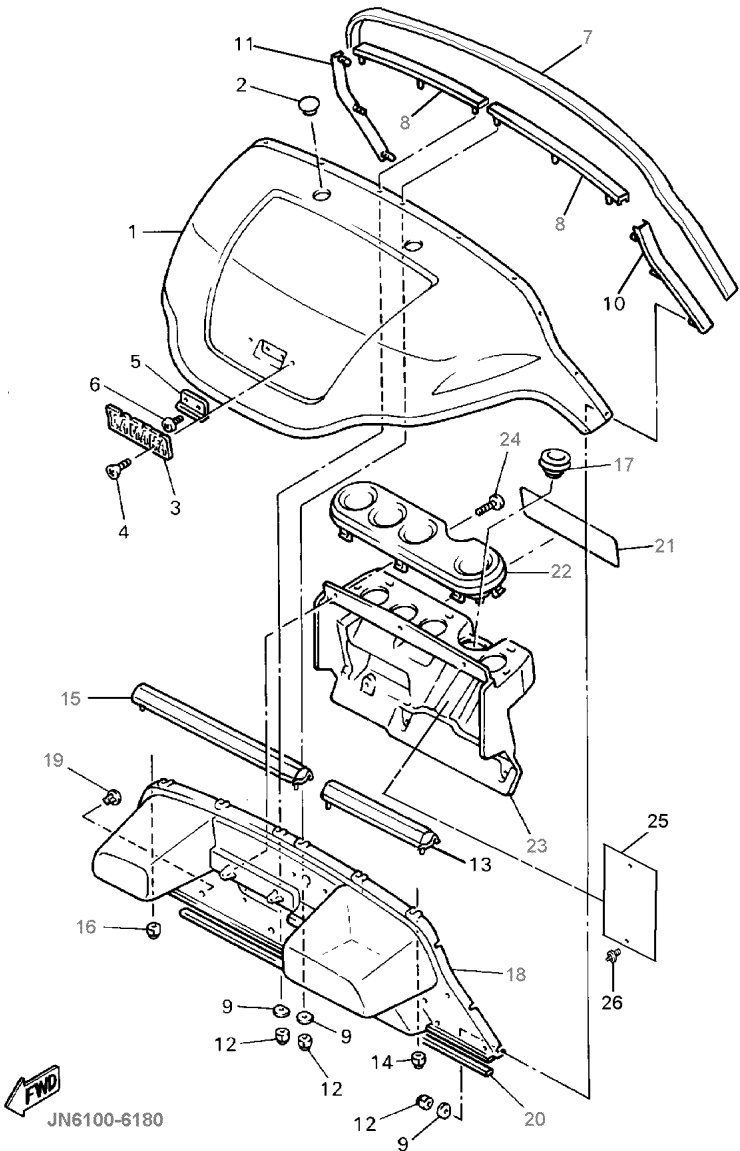
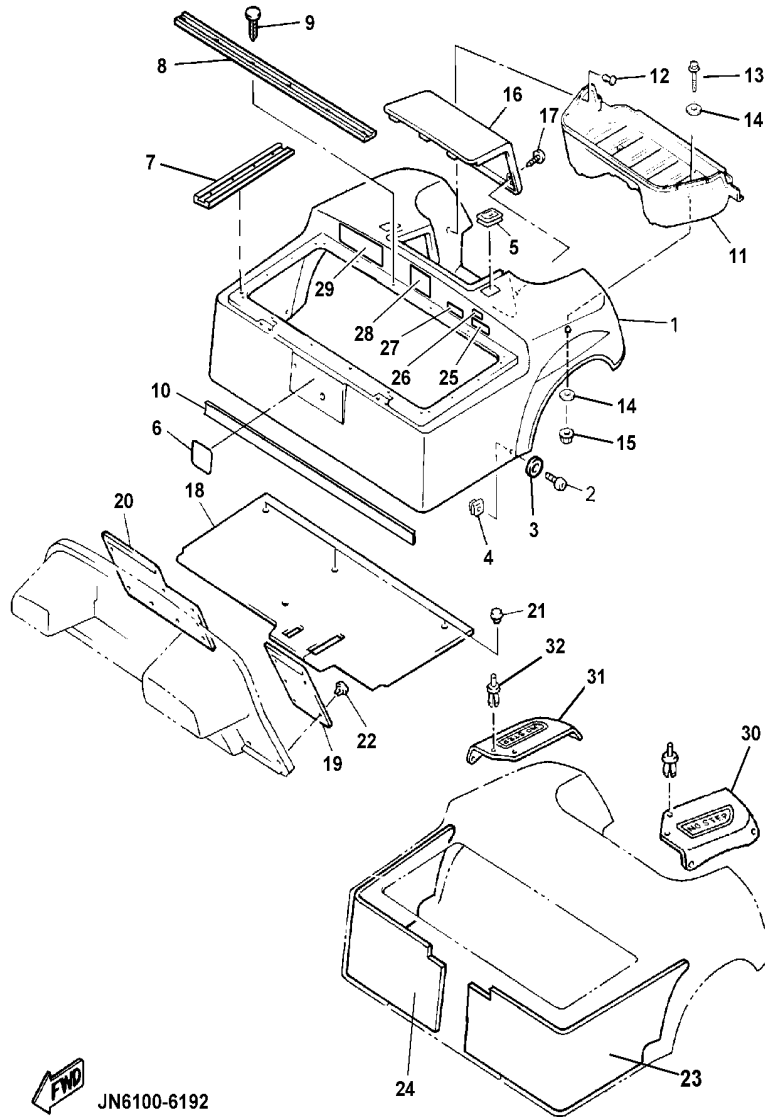



FIG. 27 BODY

REF NO.	PART NUMBER	DESCRIPTION	QTY	REMARKS
22	JN6-K835E-00-00	HOLDER, BEVERAGE	1	
23	JN3-K835G-00-00	HOUSING, HOLDER	1	SEE NOTE "A"
24	97707-60130-00	SCREW, PAN HEAD	6	
25	JN6-K8182-00-00	PLATE, 2	1	
26	90267-63047-00	RIVET, BLIND	2	

NOTE "A": When replacing "Housing Holder JN3-K835G-00-00" you should also replace "Label Warning 8 JN3-K7768-**-00".

FIG. 28 BODY 2



 JN6100-6192

REF NO.	PART NUMBER	DESCRIPTION	QTY	REMARKS
1	JN6-K8142-00-00	PANEL, REAR BODY	1	IVORY SEE NOTE "A"
	JN6-K8142-10-00	PANEL, REAR BODY	1	RED SEE NOTE "A"
	JN6-K8142-30-00	PANEL, REAR BODY	1	TEAL SEE NOTE "A"
	JN6-K8142-50-00	PANEL, REAR BODY	1	HUNTER GRN SEE NOTE "A"
2	90110-06200-00	BOLT, HEX. SOCKET	2	
3	90201-068H0-00	WASHER, PLAIN	2	
4	90183-06811-00	NUT, SPRING	2	
5	JN3-K8363-00-00	PROTECTOR	2	
6	JN3-K7741-00-00	INDICATOR, 1	1	SEE NOTE "A"
7	JN3-K8425-00-00	SEAL, SEAT	2	
8	JN3-K842A-00-00	SEAL, SEAT 2	2	
9	90338-05834-00	PLUG	20	
10	JN6-K824E-00-00	TRIM, REAR BODY	1	
11	JF2-K8237-00-00	COVER, REAR FLOOR	1	
12	90269-08069-00	RIVET	7	
13	90101-06876-00	BOLT, HEX HEAD W/WASHER	2	UR, F# JN6-007520~
14	90201-068G7-00	WASHER, PLAIN	4	UR, F# JN6-007520~
15	90185-06836-00	NUT, SELF LOCK	2	UR, F# JN6-007520~
16	JN3-K8151-00-00	PANEL, INSPECTION	1	
17	90267-36853-00	RIVET, BLIND	2	
18	JN6-K8233-00-00	MAT, MAIN FLOOR 3	1	
19	JN6-K8231-00-00	MAT, MAIN FLOOR 1	1	
20	JN6-K8232-00-00	MAT, MAIN FLOOR 2	1	
21	90269-08813-00	RIVET	4	

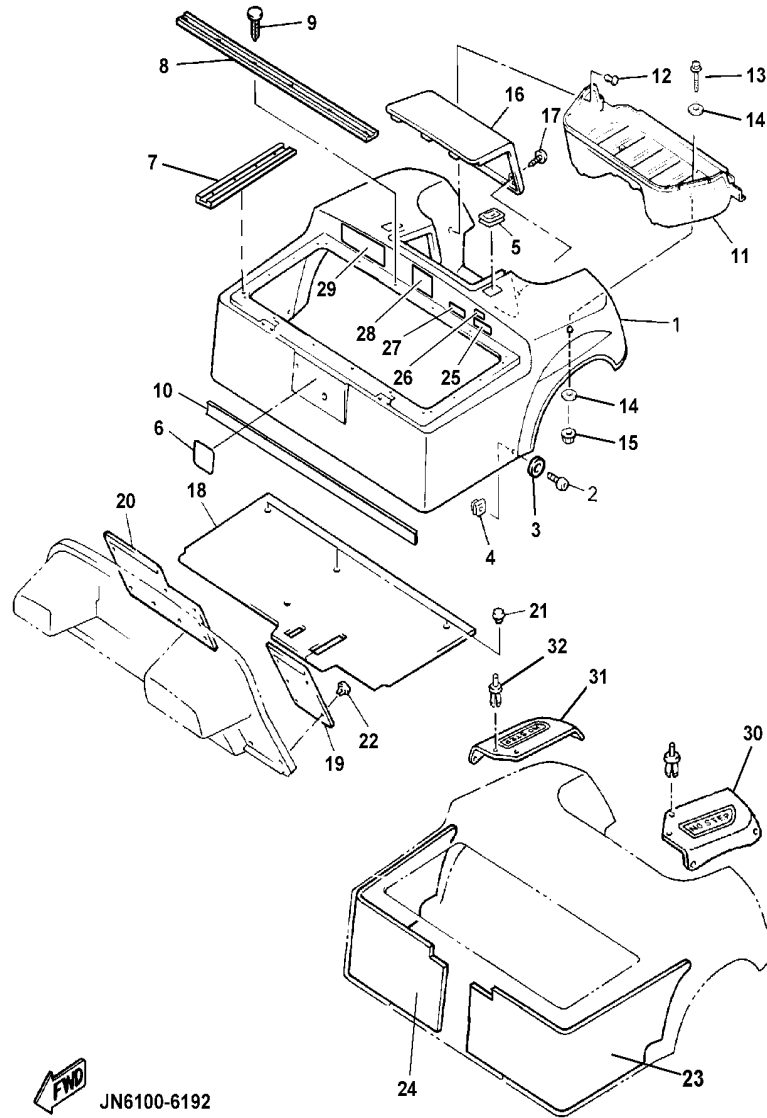
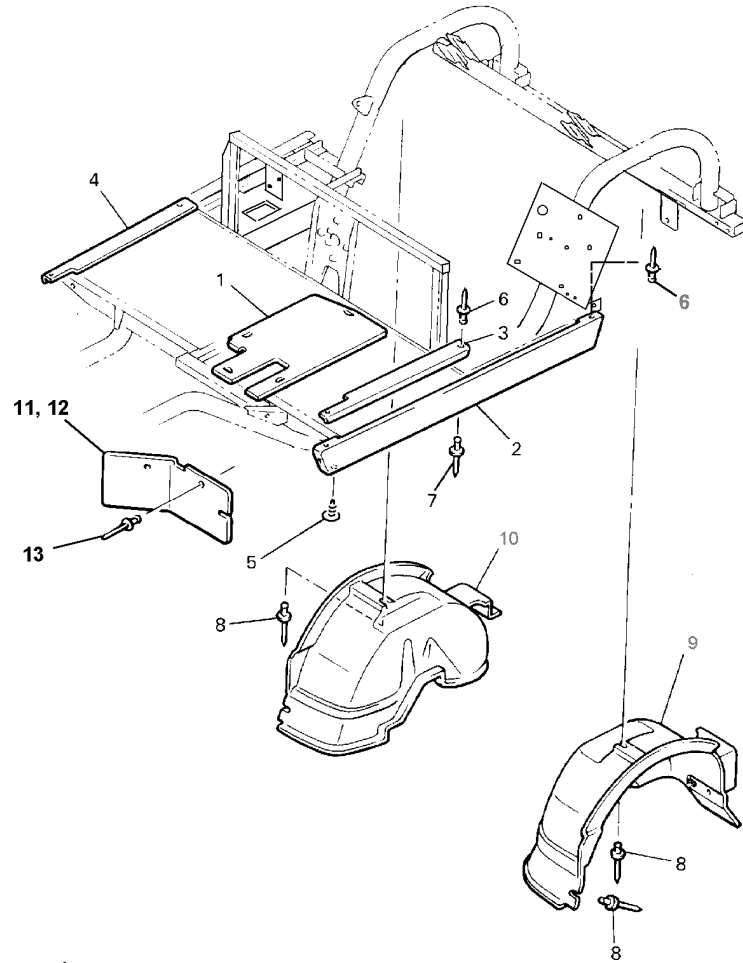

FIG. 28 BODY 2

REF NO.	PART NUMBER	DESCRIPTION	QTY	REMARKS
22	90267-63047-00	RIVET, BLIND	10	
23	JN6-K8251-01-00	PAD, SILENCER 1	1	
24	JN6-K8252-01-00	PAD, SILENCER 2	1	
25	JN6-F4236-00-00	MARK 2	1	UR, F# JN6-000101~
	JN6-F4236-10-00	MARK 2	1	UR, F# JN6-112964~
	JN6-F4236-20-00	MARK 2	1	UR, F# JN6-212001~
	JN6-F4236-30-00	MARK 2	1	UR, F# JN6-312501~
	JN6-F4236-40-00	MARK 2	1	UR, F# JN6-
26	JN6-F4239-00-00	MARK 5	1	UR
27	JN6-H2377-00-00	LABEL	1	UR, SEE NOTE "A"
28	JN3-K8299-10-00	PLATE, CAUTION 3	1	UR, SEE NOTE "A"
29	JN3-K8297-10-00	PLATE, CAUTION 1	1	UR, SEE NOTE "A"
30	JN3-K8243-00-00	MAT, BODY SIDE LEFT	1	F# JN6-100101~
31	JN3-K8244-00-00	MAT, BODY SIDE RIGHT	1	F# JN6-100101~
32	90269-07810-00	RIVET	10	F# JN6-100101~

NOTE "A": When replacing "Panel Rear Body JN6-K8142-**-00" you must also replace "Indicator 1 JN3-K7741-00-00", "Label JN6-H2377-00-00", "Plate Caution 3 JN3-K8299-10-00", and "Plate Caution 1 JN3-K8297-10-00".

FIG. 29 BODY FITTING



REF NO.	PART NUMBER	DESCRIPTION	QTY	REMARKS
1	JN6-K8271-00-00	SERVICE LID	1	
2	JF2-K818A-00-00	PROTECTOR, SIDE	2	
3	JF2-K8215-10-00	PLATE, SIDE TRIM	1	
4	JF2-K821F-10-00	PLATE, SIDE TRIM	1	
5	90338-05829-00	PLUG	4	
6	90267-48154-00	RIVET, BLIND	6	
7	90267-48101-00	RIVET, BLIND	4	
8	90267-48086-00	RIVET, BLIND	4	
9	JF2-K8191-00-00	PANEL, REAR FENDER	1	
10	JF2-K8192-00-00	PANEL, REAR FENDER	1	
11	JF2-K8187-00-00	FLAP, FRONT FENDER LEFT	1	F# JN6-200101~
12	JF2-K8189-00-00	FLAP, FRONT FENDER RIGHT	1	F# JN6-200101~
13	90267-48831-00	RIVET, BLIND	4	F# JN6-200101~

 JN6100-6201

FIG. 30 CARRIER

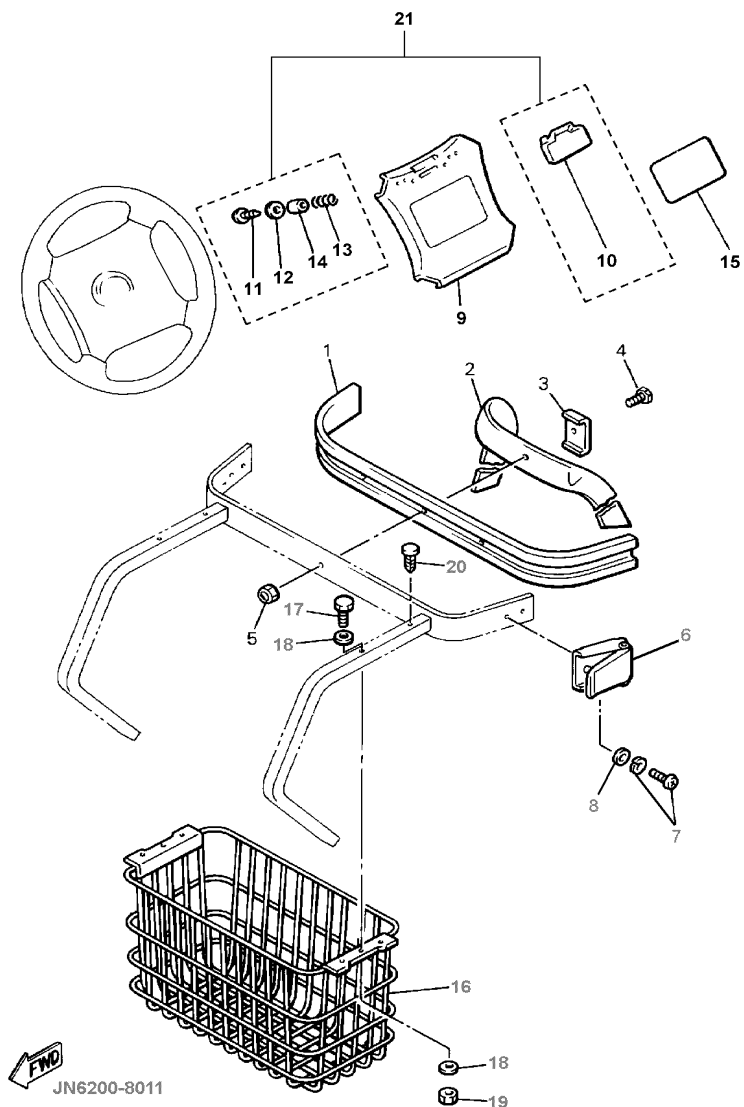

REF NO.	PART NUMBER	DESCRIPTION	QTY	REMARKS
1	JF2-K8356-00-00	PAD, BAG SUPPORT	1	
2	JN6-K8355-00-00	BAND	1	
3	J38-78367-00-00	PLATE, ANCHOR	1	
4	90101-06865-00	BOLT, HEX.	1	
5	90185-06836-00	NUT, SELF LOCKING	1	
6	JN6-K8380-00-00	LOCK ASSY.	2	
7	90159-06845-00	SCREW, WITH WASHER	4	
8	9299R-06200-00	WASHER, PLAIN	4	
9	JN3-K8357-00-00	HOLDER, 1	1	SEE NOTE "A"
10	JN6-K8358-00-00	HOLDER, 2	1	
11	97707-40625-00	SCREW, PAN HEAD	2	
12	90201-044H9-00	WASHER, PLAIN	2	
13	90502-10013-00	SPRING, CONICAL	2	
14	90387-046N7-00	COLLAR	2	
15	JN3-K7762-01-00	LABEL, WARNING 2	1	UR, FOR USA SEE NOTE "A"
	JN3-K7762-10-00	LABEL, WARNING 2	1	UR, FOR CAN SEE NOTE "A"
	JN3-K7762-20-00	LABEL, WARNING 2	1	UR, FOR EUR SEE NOTE "A"
16	JN3-K8340-00-00	LUGGAGE RACK	1	
17	90111-08803-00	BOLT, HEX. SOCKET	2	
18	90201-08103-00	WASHER, PLAIN	4	
19	90185-08832-00	NUT, SELF-LOCKING	2	
20	90338-09828-00	PLUG	2	
21	JN6-K8358-00-KT	SCORECARD HOLDER KIT	1	SEE NOTE "B"

NOTE "A": When replacing "Holder 1 JN3-K8357-00-00" you must also replace "Label Warning 2 JN3-K7762-**-00".

NOTE "B": Includes 10, 11, 12, 13, 14

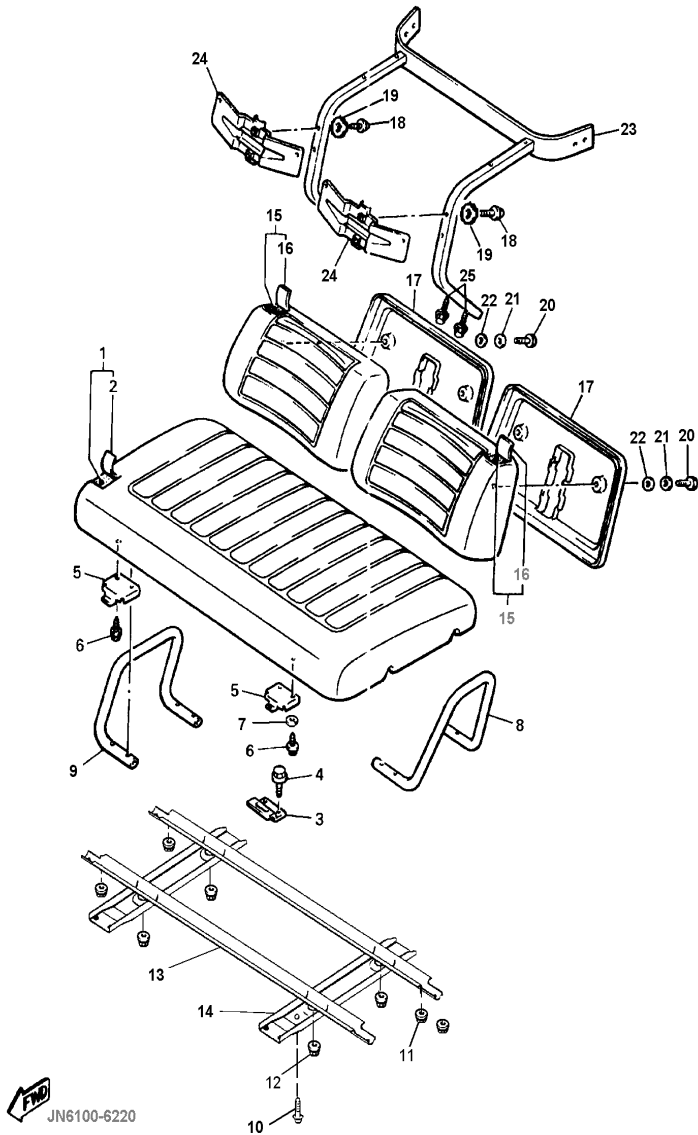
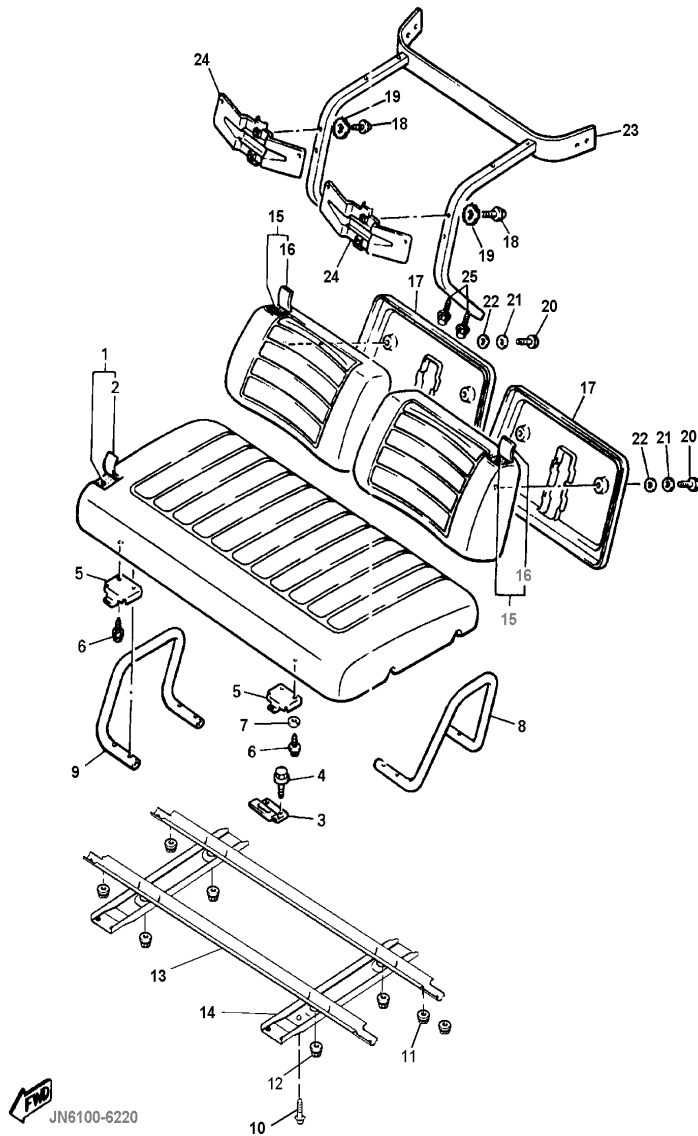

FIG. 31 SEAT

REF NO.	PART NUMBER	DESCRIPTION	QTY	REMARKS
1	JN6-K8401-10-00	CUSHION SEAT	1	UR, F# JN6-300101~
2	JN6-K8404-09-00	.COVER, SEAT	1	F# ~JN6-324396
	JN6-K8404-10-00	.COVER, SEAT	1	F# JN6-400101~
3	JF2-K8427-00-00	HINGE, SEAT FEMALE	2	
4	90105-06903-00	BOLT, FLANGE	4	
5	JN3-K8426-01-00	HINGE, SEAT MALE	2	UR, F# JN6-212472~
6	97095-05012-00	BOLT HEX. HEAD	4	F# ~JN6-212471
	90111-06810-00	BOLT, BUTTON	4	F# JN6-212472~
7	92990-05100-00	WASHER, LOCK	4	F# ~JN6-212471
	90204-06870-00	WASHER, LOCK	4	F# JN6-212472~
8	JN6-K8361-00-00	ARM REST 1	1	
9	JN6-K8362-00-00	ARMREST 2	1	
10	90167-04815-00	SCREW, P/H TAPPING	4	
11	90185-08839-00	NUT, SELF LOCKING	8	
12	95617-08200-00	NUT, U-FLANGE	4	
13	JN6-K8121-00-00	REINFORCEMENT 1	2	
14	JN6-K8122-01-00	REINFORCEMENT 2	2	UR, SEE NOTE "A" F# JN6-212472~
15	JN3-K8402-00-00	BACK, SEAT SUB.	2	
16	JN3-K841G-09-00	.COVER, SEAT BACK 2	1	
17	JN3-K8413-00-00	COVER, SEAT BACK	2	
18	90119-08820-00	BOLT, HEX. W/WASHER	4	
19	90201-098J4-00	WASHER, PLAIN	4	
20	958950-06025-00	BOLT, FLANGE	4	
21	90201-068G0-00	WASHER, PLAIN	4	
22	90201-068G6-00	WASHER, PLAIN	4	

NOTE "A": For early units up to and including F# JN6-212471, you must also use REF Numbers 5 (JN3-K8426-01-00, Hinge, Seat Male), 6 (90111-06810-00, Bolt Button) and 7 (90204-06870-00, Washer, Lock).

FIG. 31 SEAT



REF NO.	PART NUMBER	DESCRIPTION	QTY	REMARKS
23	JN3-K8423-11-00	SUPPORT, SEAT BACK	1	
24	JN3-K842H-00-00	RETAINER, SEAT	2	
25	95817-08045-00	BOLT, FLANGE	4	

 JN6100-6220

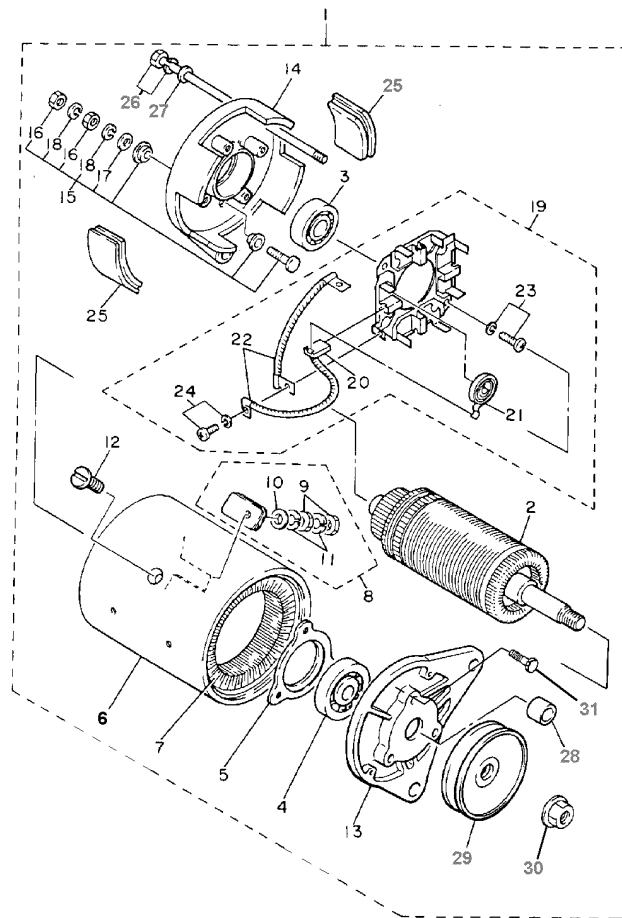

FIG. 32 STARTER GENERATOR

REF NO.	PART NUMBER	DESCRIPTION	QTY	REMARKS
1	JN6-H1100-01-00	STARTER GENERATOR	1	
2	JN3-H1150-00-00	.ARMATURE ASSY	1	
3	93306-20226-00	.BEARING 1 (6202 SD)	1	
4	J10-81158-10-00	.BEARING 2 (6203 SD)	1	
5	J10-81159-10-00	.HOLDER, BEARING	1	
6	JN6-H1110-10-00	.STATOR ASSY	1	
7	JN6-H1160-10-00	.FIELD COIL ASSY	1	
8	J10-81148-10-00	.SCREW 4	2	
9	95380-06600-00	.NUT	4	
10	92990-06600-00	.WASHER, WAVE	2	
11	92995-06100-00	.WASHER, WAVE	4	
12	J10-81146-10-00	.SCREW 2	4	
13	J38-81165-10-00	.BRACKET, STARTER GENERATOR 1	1	
14	J10-81166-10-00	.BRACKET, STARTER GENERATOR 2	1	
15	J10-81147-10-00	.SCREW 3	2	
16	95380-06600-00	.NUT	4	
17	92990-06600-00	.WASHER, WAVE	2	
18	92995-06100-00	.WASHER, WAVE	4	
19	JF2-81119-00-00	.BRUSH HOLDER ASSY	1	
20	JF2-81111-00-00	.BRUSH	4	
21	J38-81113-10-00	.SPRING, BRUSH	4	
22	J10-81115-10-00	.WIRE, LEAD	2	
23	98507-05016-00	.SCREW, PAN HEAD	2	
24	98580-04010-00	.SCREW, PAN HEAD	4	
25	J10-81129-10-00	.COVER, BRUSH	4	
26	J10-81145-10-00	.SCREW 1	2	
27	92990-06600-00	.WASHER, PLAIN	2	



JN6100-6231

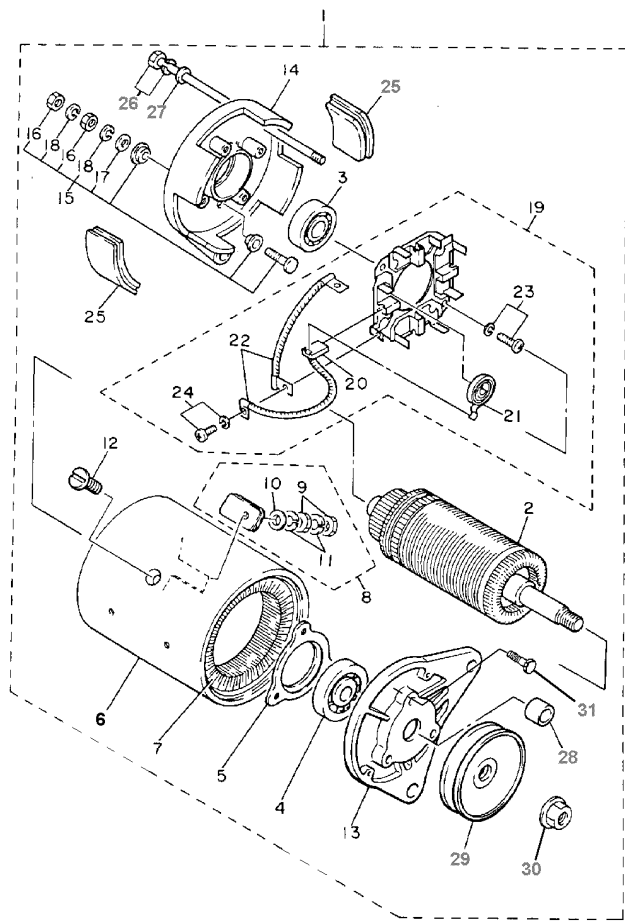
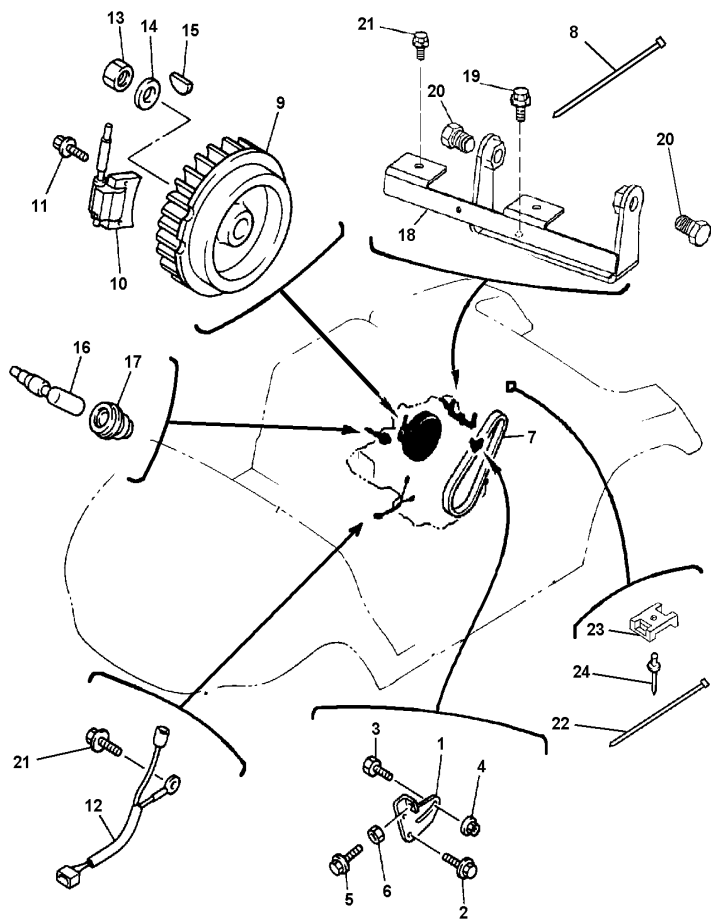

FIG. 32 STARTER GENERATOR

REF NO.	PART NUMBER	DESCRIPTION	QTY	REMARKS
28	JN3-H1661-00-00	.SPACER	1	
29	JN3-H1161-00-00	.PULLEY	2	
30	90179-16889-00	.NUT, FLANGE	1	
31	98507-05018-00	.SCREW	3	

 JN6100-6231

FIG. 33 ELECTRICAL 1



 JN6100-6240

REF NO.	PART NUMBER	DESCRIPTION	QTY	REMARKS
1	JN6-H1170-00-00	TENSIONER ASSY	1	
2	95817-08020-00	BOLT, FLANGE	2	
3	90109-087A5-00	BOLT	1	
4	95707-08500-00	NUT, FLANGE	1	
5	90107-06035-00	BOLT, HEX.	1	
6	95317-06600-00	NUT, HEX.	1	
7	JN6-H1173-00-00	BELT	1	
8	90464-09823-00	CLAMP	1	
9	JN6-85650-00-00	ROTOR ASSY.	1	
10	JN6-85640-00-00	T.C.I. UNIT	1	
11	95817-06025-00	BOLT, FLANGE	2	
12	JN6-82318-00-00	WIRE, SUB-LEAD	1	
13	95307-18600-00	NUT, HEX.	1	
14	90201-18620-00	WASHER, PLAIN	1	
15	90280-04052-00	KEY, WOODRUFF	1	
16	85G-82370-20-00	PLUG CAP ASSY	1	
17	JE8-82372-00-00	SEAL, PLUG CAP	1	
18	JN6-H1171-00-00	BRACKET, STARTER GENERATOR	1	
19	95817-08020-00	BOLT, FLANGE	2	
20	95817-12025-00	BOLT, FLANGE	2	
21	95817-06016-00	BOLT, FLANGE	3	
22	90464-40825-00	CLAMP	2	
23	90207-05800-00	WASHER, FINISH	1	
24	90267-48838-00	RIVET	1	

FIG. 34 ELECTRICAL 2

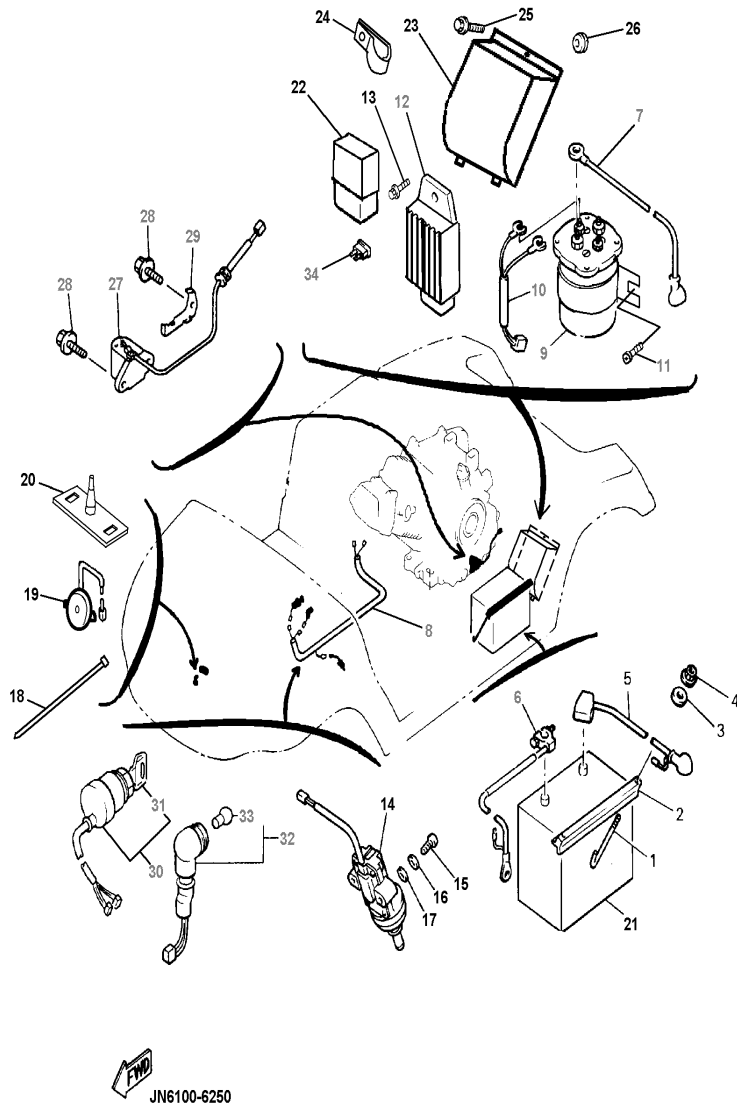

REF NO.	PART NUMBER	DESCRIPTION	QTY	REMARKS
1	JN3-H2133-00-00	SCREW, FITTING	2	
2	J55-H2136-00-00	PLATE, BATTERY	1	
3	92907-06200-00	WASHER, PLAIN	2	
4	95707-06500-00	NUT, FLANGE	2	
5	JN6-H2115-01-00	WIRE, PLUS LEAD	1	
6	JN6-H2116-01-00	WIRE, MINUS LEAD	1	
7	JN6-H2117-00-00	WIRE, LEAD	1	
8	JN6-H2590-00-00	WIRE HARNESS	1	WITH #33 FUSE
9	JF2-H1950-00-00	RELAY ASSY.	1	
10	JN6-H2105-00-00	HARNESS, WIRE	1	
11	90163-06005-00	SCREW, HEX. T	2	
12	JF2-81910-01-00	VOLTAGE REGULATOR	1	
13	95817-06016-00	BOLT, FLANGE	1	
14	JF7-82817-20-00	SWITCH, ACCELERATOR STOP	1	
15	98507-05025-00	SCREW, PAN HEAD	2	
16	92907-05100-00	WASHER, LOCK	2	
17	92907-05600-00	WASHER, PLATE	2	
18	90464-31827-00	CLAMP	4	
19	JR1-H3383-01-00	BUZZER	1	
20	JN6-H3386-00-00	STAY, BUZZER	1	
21	*	BATTERY ASSY.	1	LM
22	4U8-81950-02-00	RELAY ASSY.	1	
23	JN6-H1942-00-00	COVER	1	
24	90461-16802-00	CLAMP	1	
25	95817-06016-00	BOLT, FLANGE	2	
26	90480-25856-00	GROMMET	1	
27	JN6-85720-12-00	OIL LEVEL GAUGE	1	

FIG. 34 ELECTRICAL 2

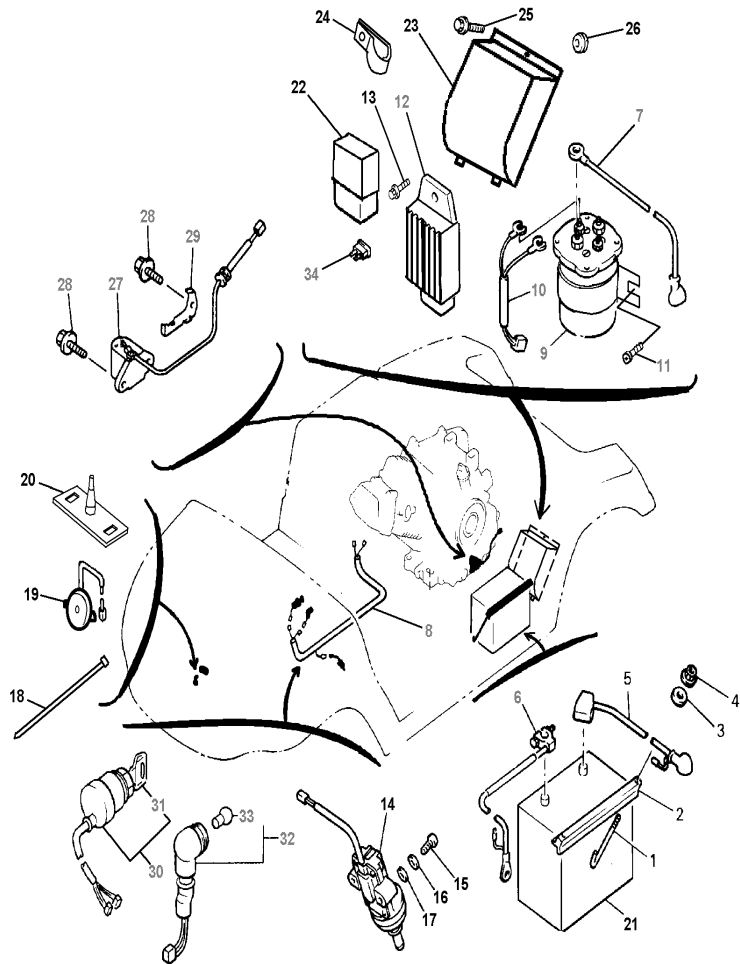

 JN6100-6250

REF NO.	PART NUMBER	DESCRIPTION	QTY	REMARKS
28	95817-06012-00	BOLT, FLANGE	4	
29	JN6-85724-00-00	CLAMP, OIL LEVEL	1	
30	JN8-82510-01-00	MAIN SWITCH	1	
31	J44-82511-00-YY	KEY, MAIN SWITCH	1	
32	JN6-83530-00-00	PILOT LAMP A	1	
33	123-83516-21-XX	.BULB, (12V-3.4W)	1	
34	42X-82151-00-00	FUSE (10A-BLADE)	1	

FIG. 35 OPTIONAL SEAT ADJUSTER

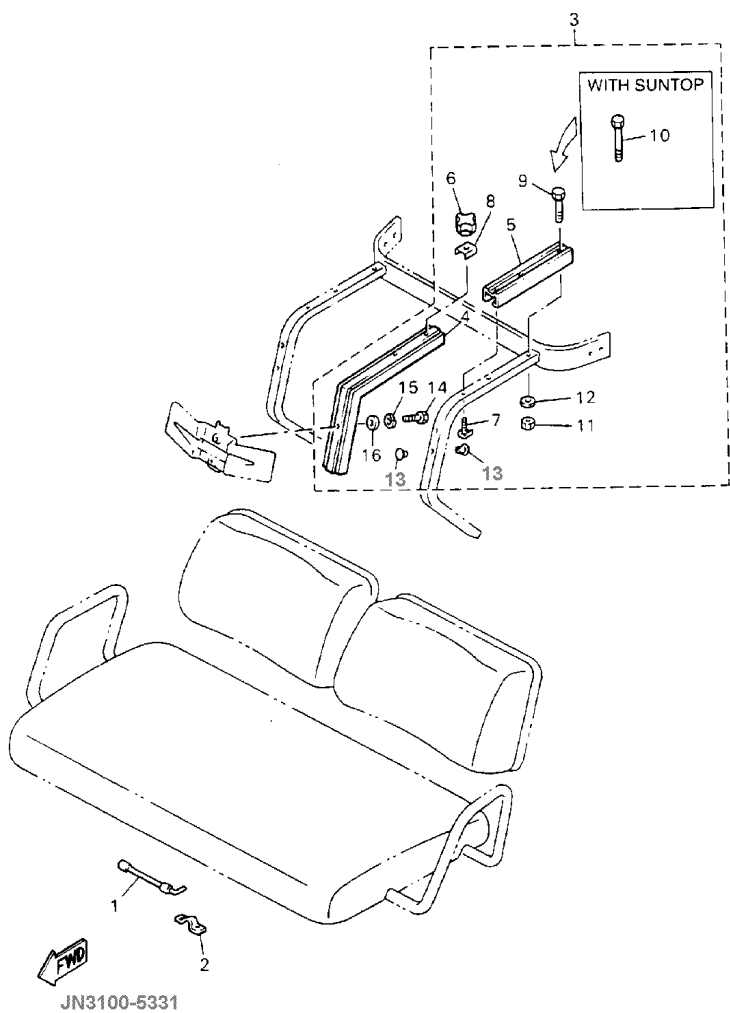

REF NO.	PART NUMBER	DESCRIPTION	QTY	REMARKS
1	JN3-K8421-00-00	SUPPORT, SEAT	1	
2	JF2-K8422-00-00	BRACKET, SEAT SUPPORT	1	
3	JN3-K8450-00-00	SEAT ADJUSTER ASSY	1	
4	JN3-K845A-00-00	.MEMBER, SLIDE SEAT	1	
5	JN3-K8451-00-00	.FRAME, SLIDE SEAT	1	
6	JN3-K8452-00-00	.SEAT-ADJUSTER	1	
7	JN3-K8459-00-00	.REINFORCEMENT, 1	1	
8	JN3-K845E-00-00	.REINFORCEMENT, 2	1	
9	97080-08045-00	.BOLT, HEXAGON	2	
10	97080-08070-00	.BOLT, HEXAGON	2	
11	95680-08100-00	.NUT, U	2	
12	92990-08200-00	.WASHER, PLAIN	2	
13	90338-09828-00	.PLUG	4	
14	97080-08020-00	.BOLT, HEX. HEAD	2	
15	92990-08100-00	.WASHER, SPRING	2	
16	92990-08600-00	.WASHER, PLATE	2	

FIG. 36 OPTIONAL HUB CAPS

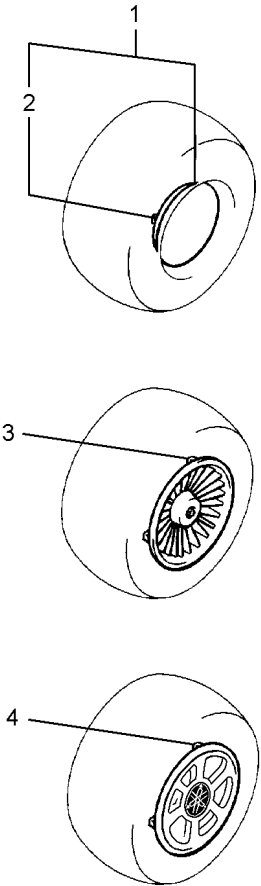

REF NO.	PART NUMBER	DESCRIPTION	QTY	REMARKS
1	JG5-F512L-00-00	HUB-CAP, PLAIN	4	Comes with clips
2	JG5-F512N-00-00	.CLIP, HUB CAP	3	
3	JG5-F512M-00-00	HUB-CAP, MAG-STYLE	4	Comes with clips
4	JN6-HUBCP-TF-00	HUB-CAP, TUNING FORK LOGO	4	Comes with clips

 JN6100-6261

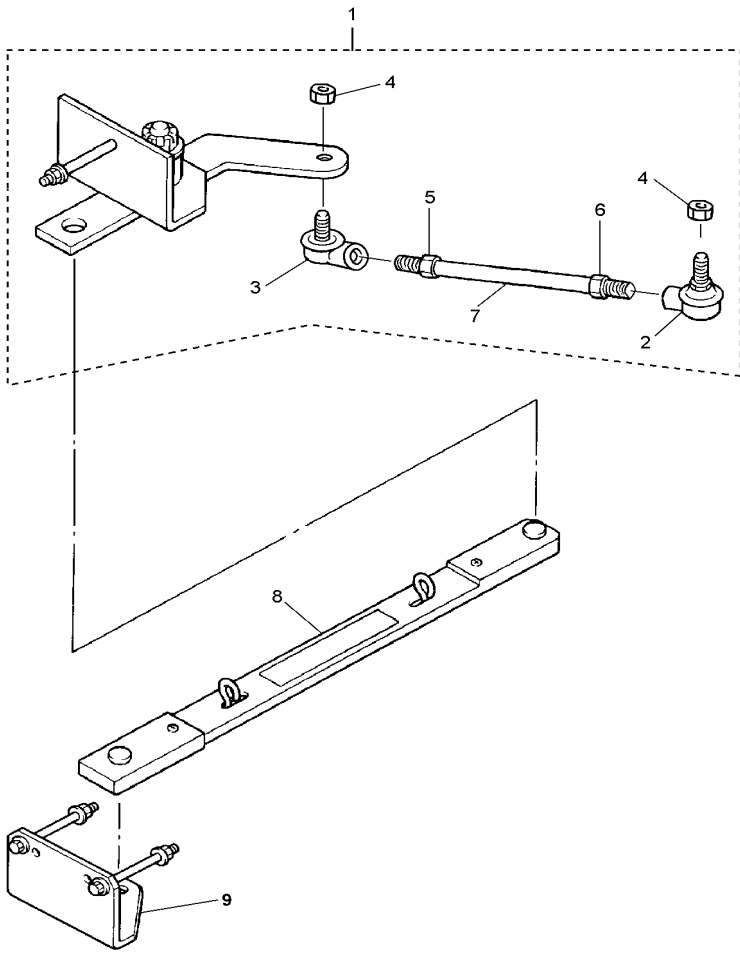
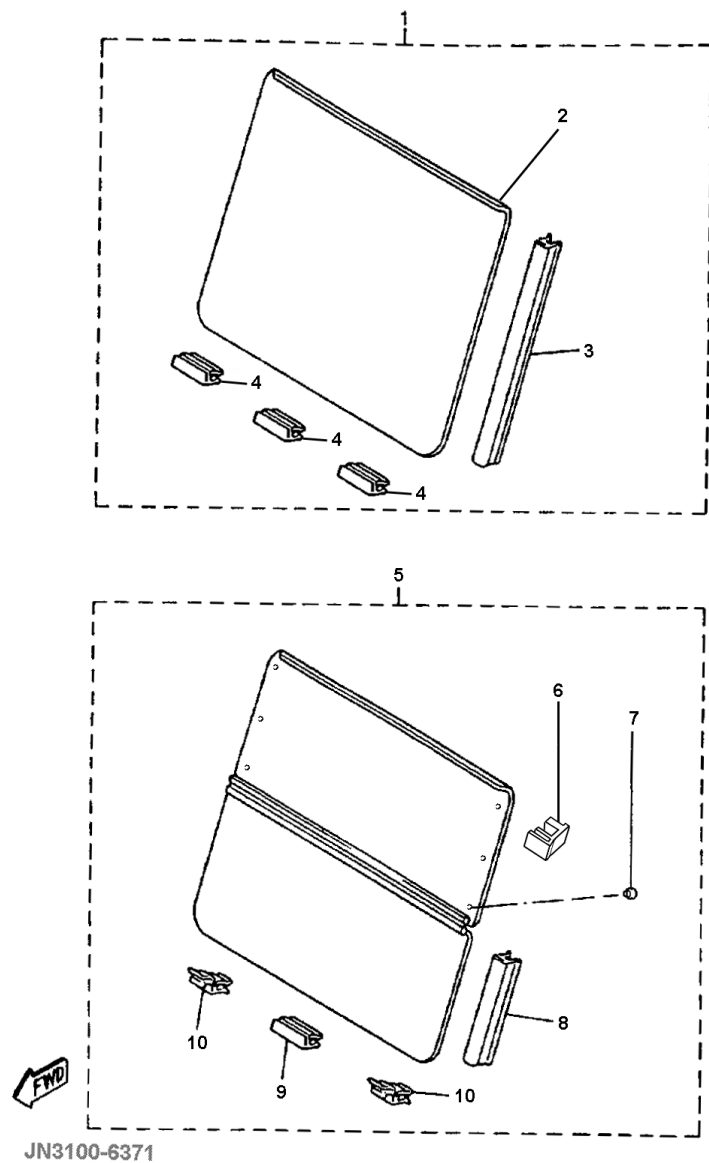

FIG. 37 OPTIONAL DRAW BAR

REF NO.	PART NUMBER	DESCRIPTION	QTY	REMARKS
1	JN3-F389K-01-00	ARM, PIVOT ASSY.	1	
2	JN6-F3841-00-00	UNIVERSAL JOINT RH	1	
3	JN6-F3845-00-00	UNIVERSAL JOINT LH	1	
4	95607-10200-00	NUT, U-FLANGE	2	
5	90170-12054-00	NUT (RH THREAD)	1	
6	95317-12700-00	NUT (LH THREAD)	1	
7	JN3-F3880-00-00	TIE ROD	1	
8	JG5-F389J-00-00	DRAW BAR ASSY.	1	
9	JN3-F3802-00-00	REAR HITCH ASSY.	1	

 JN6100-6271

FIG. 38 OPTIONAL WINDSHIELD



REF NO.	PART NUMBER	DESCRIPTION	QTY	REMARKS
1	JN3-K7200-00-00	WINDSHIELD ASSY. (ONE PIECE, CLEAR)	1	UR, AP
	JN3-K7200-10-00	WINDSHIELD ASSY. (ONE PIECE, TINTED)	1	UR, AP
2	JN3-K7211-01-00	.WINDSHIELD (ONE PIECE, CLEAR)	1	UR
	JN3-K7211-11-00	.WINDSHIELD (ONE PIECE, TINTED)	1	UR
3	JN3-K838C-00-00	.HOLDER SHIELD	2	
4	JN3-K722A-01-00	.FASTENER, 2	3	
5	JN3-K7200-20-00	WINDSHIELD ASSY. (HINGED, CLEAR)	1	UR, AP
	JN3-K7200-30-00	WINDSHIELD ASSY. (HINGED, TINTED)	1	UR, AP
6	ACC-CCGLU-ES-ET	LATCH, RUBBER	2	SEE NOTE "A"
7	JN3-K7238-00-00	..DAMPER, WINDSHIELD	6	
8	JN3-K838A-00-00	.RETAINER 1	2	
9	JN3-K722A-01-00	.FASTENER 2	1	
10	JN3-K7222-00-00	.BRACKET, W/S	2	

NOTE "A": Includes adhesive. Replaces old style latch for hinged windshields.

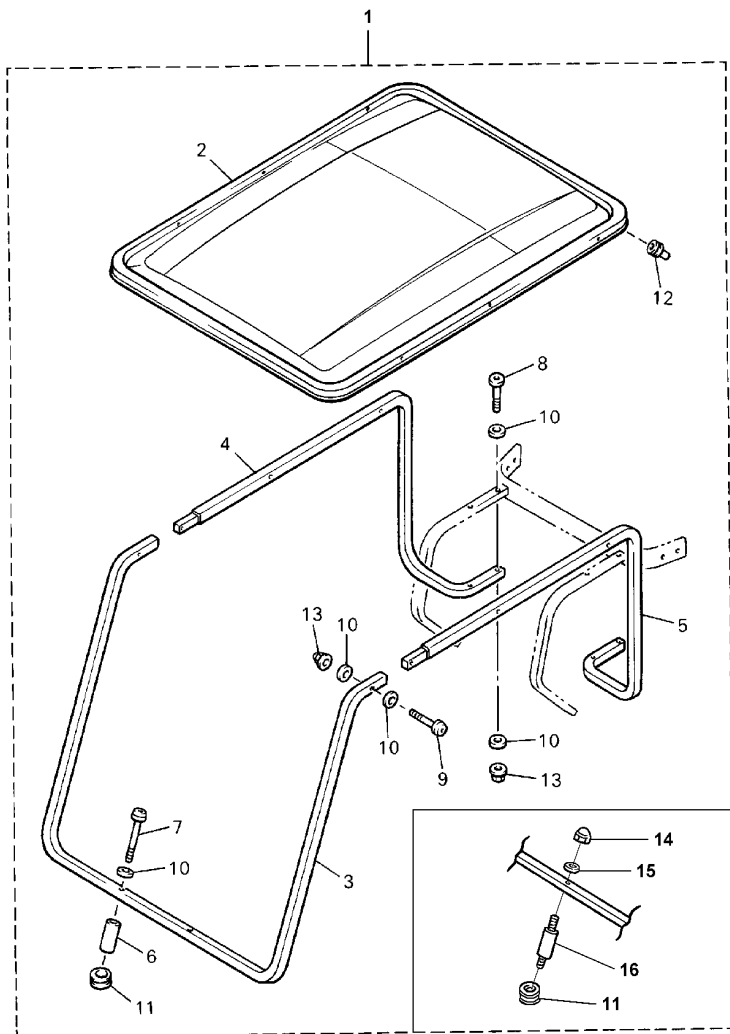

 JN3100-5371

FIG. 39 OPTIONAL SUN ROOF

REF NO.	PART NUMBER	DESCRIPTION	QTY	REMARKS
1	JN3-K8310-10-00	SUN ROOF ASSY	1	
2	JN3-K8314-00-00	.COVER, SUNROOF	1	
3	JN3-K8312-00-00	.SUPPORT, ROOF 1	1	
4	JN3-K831A-00-00	.SUPPORT, ROOF 3	1	
5	JN3-K8313-00-00	.SUPPORT, ROOF 2	1	
6	90387-09826-00	.COLLAR	2	F# ~JN6-324396
7	90101-08862-00	.BOLT, HEX.	2	F# ~JN6-324396
8	90101-22864-00	.BOLT, HEX.	4	
9	90101-22863-00	.BOLT, HEX.	6	
10	90201-088E5-00	.WASHER, PLAIN	22	
11	JN3-K832F-00-00	.GROMMET, ROOF	2	
12	JN3-K832G-00-00	.GROMMET, ROOF	2	
13	90185-12835-00	.NUT, SELF-LOCKING	10	
14	90176-08801-00	.NUT, CAP	2	F# JN6-400101~
15	90201-098J4-00	.WASHER, PLAIN	2	F# JN6-400101~
16	JN6-K834A-00-00	.REINF., HOLDER	2	F# JN6-400101~

FIG. 40 OPTIONAL ORNAMENT PLATE

REF NO.	PART NUMBER	DESCRIPTION	QTY	REMARKS
1	JN3-K814N-00-00	PLATE, ORNAMENT	1	

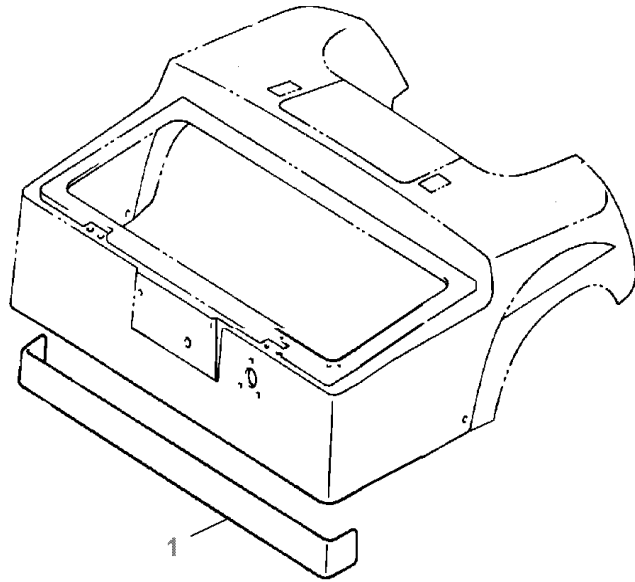

 JN6100-6291

FIG. 41 OPTIONAL FLEET NUMBERS

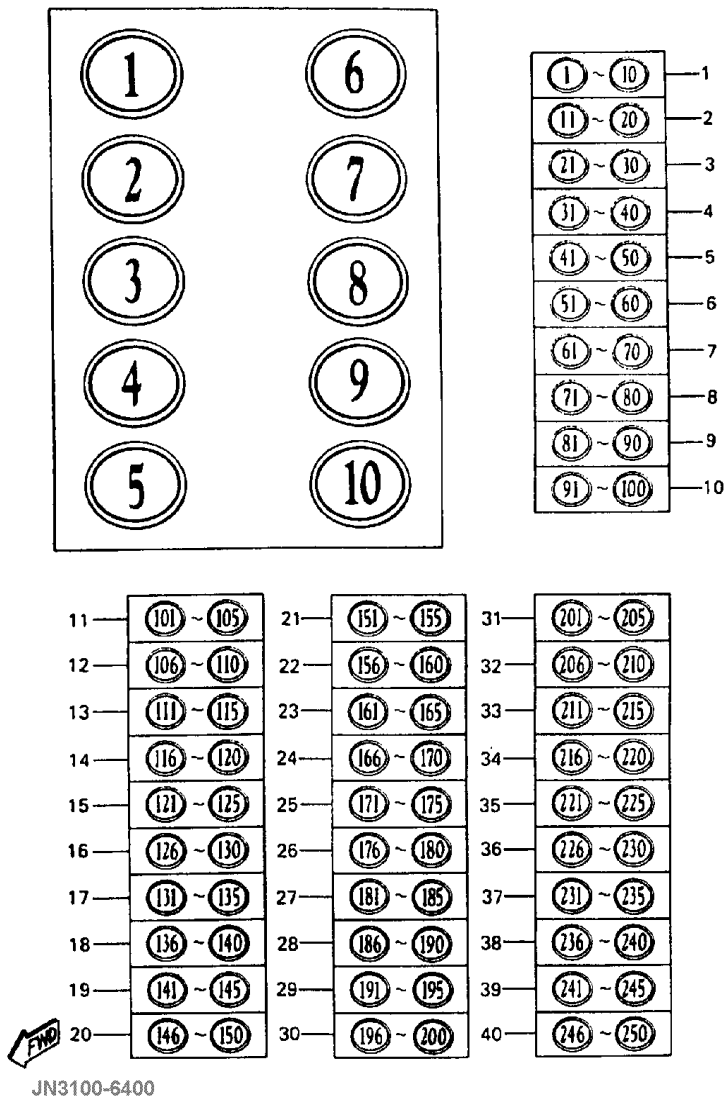

REF NO.	PART NUMBER	DESCRIPTION	QTY	REMARKS
1	JG5-K810T-10-00	FLEET, NUMBER	1	
2	JG5-K810T-20-00	FLEET, NUMBER	1	
3	JG5-K810T-30-00	FLEET, NUMBER	1	
4	JG5-K810T-40-00	FLEET, NUMBER	1	
5	JG5-K810T-50-00	FLEET, NUMBER	1	
6	JG5-K810T-60-00	FLEET, NUMBER	1	
7	JG5-K810T-70-00	FLEET, NUMBER	1	
8	JG5-K810T-80-00	FLEET, NUMBER	1	
9	JG5-K810T-90-00	FLEET, NUMBER	1	
10	JG5-K810T-00-00	FLEET, NUMBER	1	
11	JG5-K810U-A0-00	FLEET, NUMBER	1	
12	JG5-K810U-10-00	FLEET, NUMBER	1	
13	JG5-K810U-E0-00	FLEET, NUMBER	1	
14	JG5-K810U-20-00	FLEET, NUMBER	1	
15	JG5-K810U-F0-00	FLEET, NUMBER	1	
16	JG5-K810U-30-00	FLEET, NUMBER	1	
17	JG5-K810U-G0-00	FLEET, NUMBER	1	
18	JG5-K810U-40-00	FLEET, NUMBER	1	
19	JG5-K810U-H0-00	FLEET, NUMBER	1	
20	JG5-K810U-50-00	FLEET, NUMBER	1	
21	JG5-K810U-J0-00	FLEET, NUMBER	1	
22	JG5-K810U-60-00	FLEET, NUMBER	1	
23	JG5-K810U-K0-00	FLEET, NUMBER	1	
24	JG5-K810U-70-00	FLEET, NUMBER	1	
25	JG5-K810U-L0-00	FLEET, NUMBER	1	
26	JG5-K810U-80-00	FLEET, NUMBER	1	
27	JG5-K810U-M0-00	FLEET, NUMBER	1	

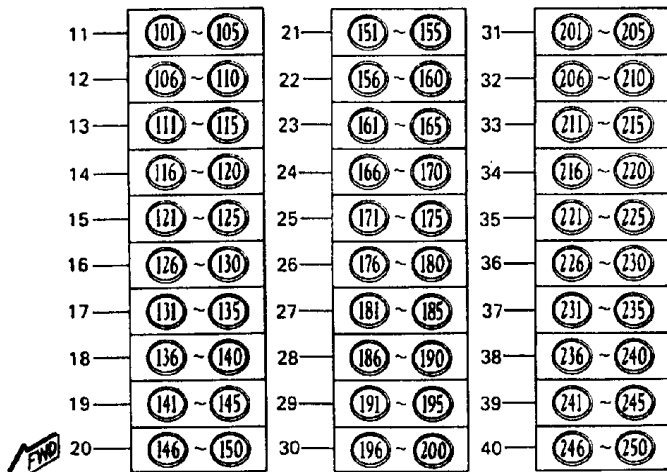
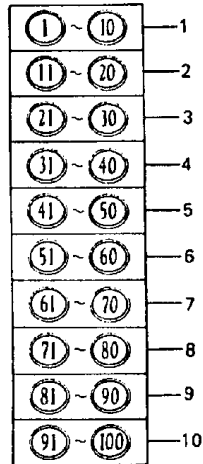
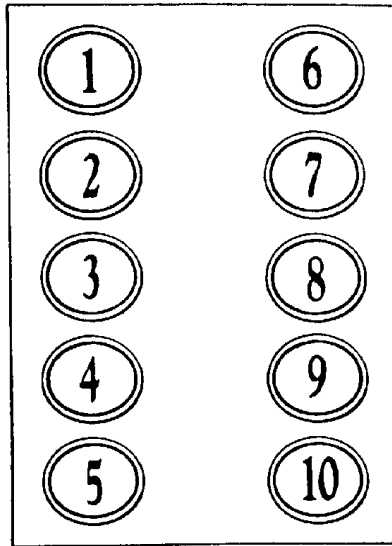

JN3100-6400

FIG. 41 OPTIONAL FLEET NUMBERS

REF NO.	PART NUMBER	DESCRIPTION	QTY	REMARKS
28	JG5-K810U-90-00	FLEET, NUMBER	1	
29	JG5-K810U-N0-00	FLEET, NUMBER	1	
30	JG5-K810U-00-00	FLEET, NUMBER	1	
31	JG5-K810V-A0-00	FLEET, NUMBER	1	
32	JG5-K810V-10-00	FLEET, NUMBER	1	
33	JG5-K810V-E0-00	FLEET, NUMBER	1	
34	JG5-K810V-20-00	FLEET, NUMBER	1	
35	JG5-K810V-F0-00	FLEET, NUMBER	1	
36	JG5-K810V-30-00	FLEET, NUMBER	1	
37	JG5-K810V-G0-00	FLEET, NUMBER	1	
38	JG5-K810V-40-00	FLEET, NUMBER	1	
39	JG5-K810V-H0-00	FLEET, NUMBER	1	
40	JG5-K810V-50-00	FLEET, NUMBER	1	

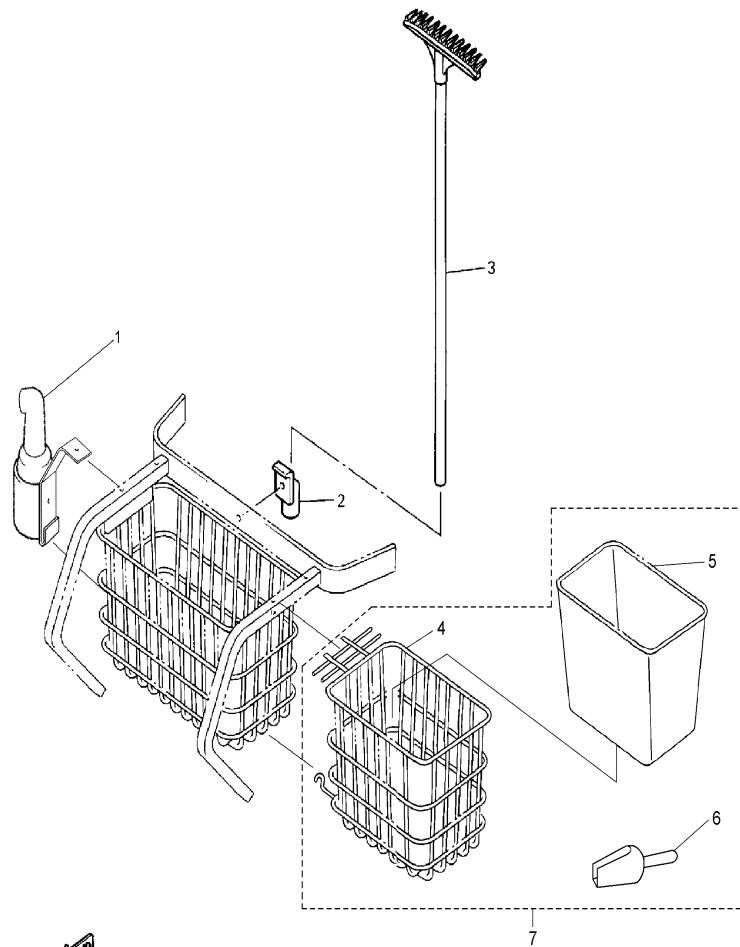

 JN3100-5401

FIG. 42 OPTIONAL SAND BOTTLE / RAKE

REF NO.	PART NUMBER	DESCRIPTION	QTY	REMARKS
1	JN3-K8309-00-00	SAND BOTTLE ASSY.	1	
	JN3-K839E-00-00	SAND BOTTLE	1	
	JN3-K839G-00-00	HOLDER, SAND BOTTLE	1	
	JN3-K839H-00-00	BRACKET, SAND BOTTLE	1	
	JN3-K839J-00-00	SLEEVE	1	
	95027-06016-00	BOLT, SMALL FLANGE	3	
	90201-088E5-00	WASHER, PLATE	1	
	95607-06200-00	NUT, SELF LOCK	3	
2	JG5-K834G-00-00	HOLDER, RAKE	1	
3	JG5-K834H-00-00	RAKE, SAND 1	1	
4	JN6-SIDEB-AS-KT	SIDE BASKET	1	
5	JN6-SANDB-UC-KT	SAND BUCKET	1	
6	JN6-SANDS-CO-OP	SAND SCOOP	1	
7	JN6-SANDB-KK-IT	SAND BUCKET KIT	1	SEE NOTE "A"

NOTE "A" : Includes 4, 5, 6

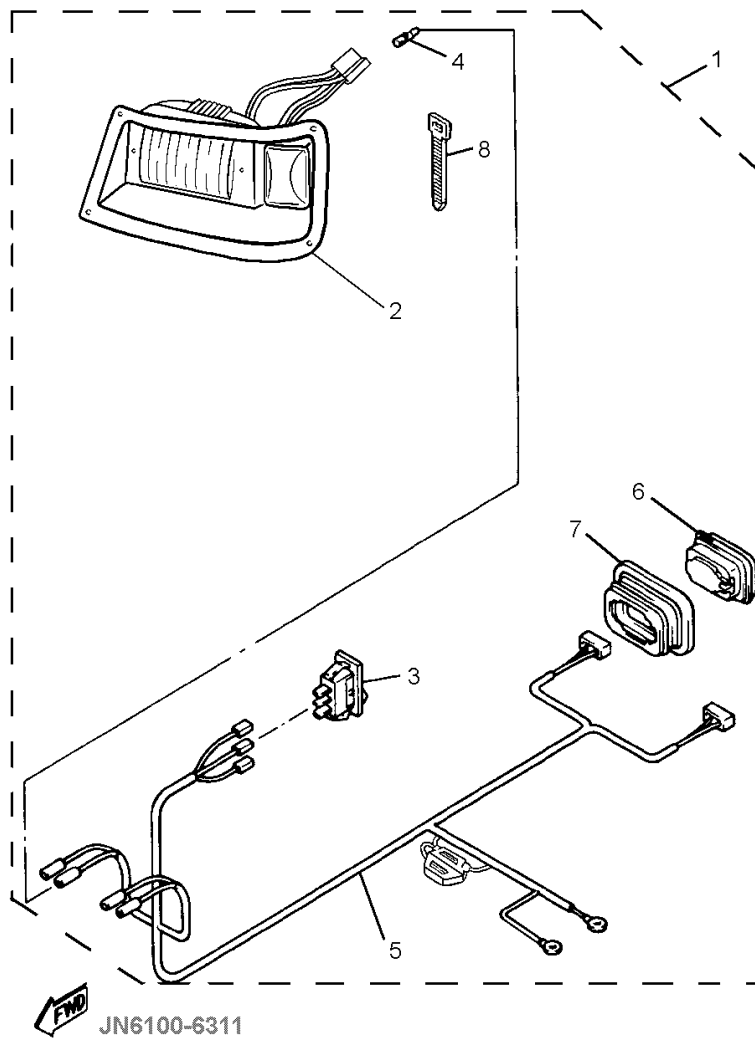

FIG. 43 OPTIONAL LIGHT KIT

REF NO.	PART NUMBER	DESCRIPTION	QTY	REMARKS
1	JN6-H430A-20-00	LIGHT KIT ASSY.	1	
2	JN3-H4303-20-00	.HEAD LIGHT UNIT ASSY.	1	INCLUDES RH & LH HEADLIGHTS
3	JN3-H3976-20-00	.SWITCH	1	
4	90890-05159-00	.BULLET, PLUG	2	
5	JN6-H4159-00-00	.CORD, HEAD LIGHT	1	
6	JN3-H4700-00-00	.TAIL LIGHT ASSY	2	
7	JN3-H4718-00-00	.GROMMET, TAIL	2	
8	90464-14806-00	.CLAMP	25	

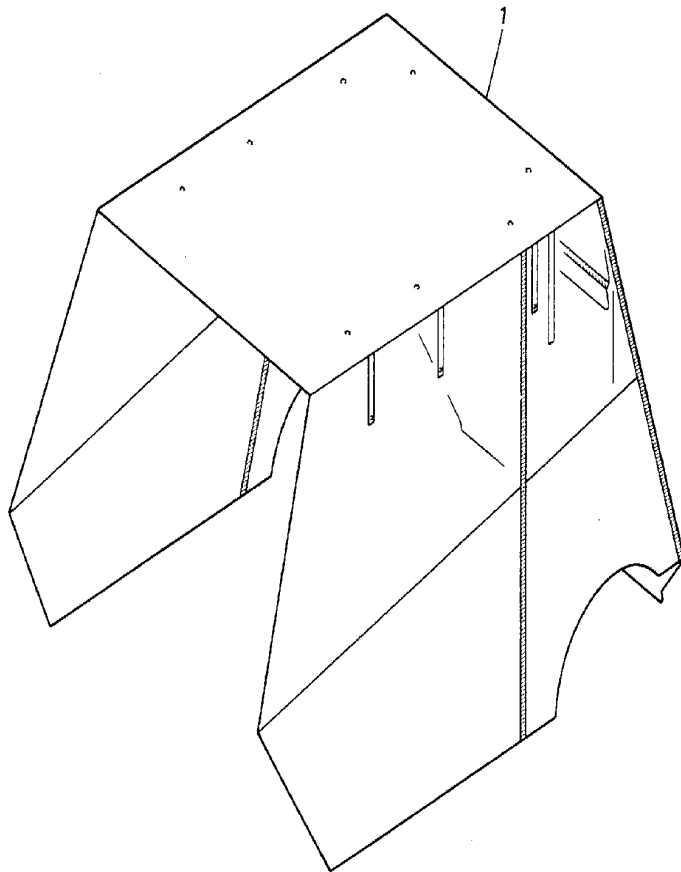

FIG. 44 OPTIONAL ENCLOSURE

REF NO.	PART NUMBER	DESCRIPTION	QTY	REMARKS
1	JN3-K832U-00-00	ENCLOSURE	1	



JN3100-6440